

MONITOUCH

Connection Manual [2]

Contents

1. Overview
2. IAI
3. IDEC
4. JTEKT
5. KEYENCE
6. KOGANEI
7. KOYO ELECTRONICS
8. LS
9. MITSUBISHI ELECTRIC
10. MODICON
11. MOELLER
12. M-SYSTEM
13. OMRON
14. Oriental Motor
15. Panasonic
16. RKC
17. RS Automation



V9 series

Hakko Electronics Co., Ltd.

Preface

Thank you for selecting the MONITOUCH V9 series.

For correct set-up of the V9 series, you are requested to read through this manual to understand more about the product.

For more information about the V9 series, refer to the following related manuals.

Manual Name	Contents	Reference No.
V9 Series Connection Manual [1]	The connection and communication parameters for the V9 series and controllers are explained in detail. Included Makers ALLEN BRADLEY, Automationdirect, Azbil, Baumuller, BECKHOFF, CHINO, CIMON, DELTA, DELTA TAU DATA SYSTEMS, EATON Cutler-Hammer, EMERSON, FANUC, Fatek Automation, FUFENG, Fuji Electric, Gammaflux, GE Fanuc, Hitachi, Hitachi Industrial Equipment Systems	2210NE
V9 Series Connection Manual [2]	The connection and communication parameters for the V9 series and controllers are explained in detail. Included Makers IAI, IDEC, JTEKT, KEYENCE, KOGANEI, KOYO ELECTRONICS, LS, MITSUBISHI ELECTRIC, MODICON, MOELLER, M-SYSTEM, OMRON, Oriental Motor, Panasonic, RKC, RS Automation	2211NE
V9 Series Connection Manual [3]	The connection and communication parameters for the V9 series and controllers are explained in detail. Included Makers SAIA, SAMSUNG, SanRex, SANMEI, SHARP, SHIMADEN, SHINKO TECHNOS, Siemens, SINFONIA TECHNOLOGY, TECO, Telemecanique, TOHO, TOSHIBA, TOSHIBA MACHINE, TURCK, UNIPULSE, UNITRONICS, VIGOR, WAGO, XINJE, YAMAHA, Yaskawa Electric, Yokogawa Electric, MODBUS, Barcode Reader, Slave Communication Function, Universal Serial Communication	2212NE
V9 Series Reference Manual [1]	The functions and instructions of the V9 series are explained.	1065NE
V9 Series Reference Manual [2]		1066NE
V9 Series Troubleshooting/Maintenance Manual	Errors and operation procedures of the V9 series are explained.	1068NE
V9 Series Hardware Specifications	Notes on usage and hardware specifications for the V9 series are explained.	2023NE
V9 Series Macro Reference	An overview of macros of V-SFT version 6 as well as macro editor operations and macro command descriptions are explained.	1071NE

For further details about PLCs, inverters, or temperature controllers, refer to the manual attached to each controller.

Notes:

1. This manual may not, in whole or in part, be printed or reproduced without the prior written consent of Hakko Electronics Co., Ltd.
2. The information in this manual is subject to change without prior notice.
3. Windows and Excel are registered trademarks of Microsoft Corporation in the United States and other countries.
4. All other company names or product names are trademarks or registered trademarks of their respective holders.
5. This manual is intended to give accurate information about MONITOUCH hardware. If you have any questions, please contact your local distributor.

Notes on Safe Usage of MONITOUCH

In this manual, you will find various notes categorized under the following two levels with the signal words "Danger" and "Caution."



DANGER

Indicates an imminently hazardous situation which, if not avoided, will result in death or serious injury.



CAUTION

Indicates a potentially hazardous situation which, if not avoided, may result in minor or moderate injury and could cause property damage.

Note that there is a possibility that an item listed under  **CAUTION** may have serious ramifications.



DANGER

- Never use the output signal of the V9 series for operations that may threaten human life or damage the system, such as signals used in case of emergency. Please design the system so that it can cope with the malfunctions of a touch switch. A malfunction of a touch switch may result in machine accident or damage.
- Turn off the power supply when you set up the unit, connect new cables, or perform maintenance or inspections. Otherwise, electrical shock or damage may occur.
- Never touch any terminals while the power is on. Otherwise, electric shock may occur.
- Put a cover on the terminals on the unit before turning the power on starting operation. Otherwise, electric shock may occur.
- The liquid crystal in the LCD panel is a hazardous substance. If the LCD panel is damaged, do not ingest the leaked liquid crystal. If the liquid crystal contacts skin or clothing, use soap and wash off thoroughly.
- Never disassemble, recharge, deform by pressure, short-circuit, reverse the polarity of the lithium battery, nor dispose of the lithium battery in fire. Failure to follow these conditions will lead to explosion or fire.
- Never use a lithium battery that is deformed, leaks, or shows any other signs of abnormality. Failure to follow these conditions may lead to explosion or fire.
- The power lamp flashes when the backlight is at the end of life or is faulty. However, the switches on the screen are operable at this time. Do not touch the screen when the screen becomes dark and the power lamp flashes. Otherwise, a malfunction may occur and result in machine accident or damage.



CAUTION

- Check the appearance of MONITOUCH when unpacked. Do not use it if any damage or deformation is found. Failure to do so may lead to fire, damage or malfunction.
- For use in a facility or for a system related to nuclear energy, aerospace, medical, traffic equipment, or mobile installations, please consult your local distributor.
- Operate (or store) the V9 series under the conditions indicated in this manual and related manuals. Failure to do so could cause fire, malfunction, physical damage or deterioration.
- Understand the following environmental limits for use and storage of MONITOUCH. Otherwise, fire or damage to the unit may result.
 - Avoid locations where there is a possibility that water, corrosive gas, flammable gas, solvents, grinding fluids or cutting oil can come into contact with the unit.
 - Avoid high temperature, condensation, and outside weather conditions, such as wind, rain or direct sunlight.
 - Avoid locations where excessive dust, salt, and metallic particles are present.
 - Avoid installing the unit in a location where vibration or physical shock may be transmitted.
- Equipment must be correctly mounted so that the main terminal of the V9 series will not be touched inadvertently. Otherwise, an accident or electric shock may occur.
- Tighten the fixtures of the V9 series evenly to a torque of 0.6 N·m. Excessive tightening may distort the panel surface. Loose tightening may cause MONITOUCH to come off, malfunction or be short-circuited.
- Check periodically that terminal screws on the power supply terminal block and fixtures are firmly tightened. Loosened screws may result in fire or malfunction.
- Tighten terminal screws on the power supply terminal block equally to a torque of 7.1 to 8.8 inch-lbf (0.8 to 1.0 N·m). Improper tightening of screws may result in fire, malfunction, or other trouble.
- The V9 series has a glass screen. Do not drop or give physical shock to the unit. Otherwise, the screen may be damaged.
- Connect the cables correctly to the terminals of the V9 series in accordance with the specified voltage and wattage. Over-voltage, over-wattage, or incorrect cable connection could cause fire, malfunction or damage to the unit.
- Be sure to establish a ground of the V9 series. The FG terminal must be used exclusively for the unit with the level of grounding resistance less than 100 Ω. Otherwise, electric shock or fire may occur.
- Prevent any conductive particles from entering into the V9 series. Failure to do so may lead to fire, damage, or malfunction.
- After wiring is finished, remove the paper used as a dust cover before starting to operate the V9 series. Operation with the cover attached may result in an accident, fire, malfunction, or trouble.
- Do not attempt to repair the V9 series at your site. Ask Hakko Electronics or the designated contractor for repairs.

CAUTION

- Do not repair, disassemble or modify the V9 series. Hakko Electronics Co., Ltd. is not responsible for any damages resulting from repair, disassembly or modification of a unit that was performed by an unauthorized person.
- Do not use a sharp-pointed tool when pressing a touch switch. Doing so may damage the screen.
- Only experts are authorized to set up the unit, connect the cables or perform maintenance and inspection.
- Lithium batteries contain combustible material such as lithium or organic solvents. Mishandling may cause heat, explosion or ignition resulting in fire or injury. Read related manuals carefully and handle the lithium battery correctly as instructed.
- Do not press two or more positions on the screen at the same time. If two or more positions are pressed at the same time, the switch located between the pressed positions activates.
- Take safety precautions during operations such as changing settings during running, forced output, start, and stop. Any misoperation may cause unexpected machine motions, resulting in machine accident or damage.
- In facilities where a failure of the V9 series could lead to accidents threatening human life or other serious damage, be sure that the facilities are equipped with adequate safeguards.
- At the time of disposal, the V9 series must be treated as industrial waste.
- Before touching the V9 series, discharge static electricity from your body by touching grounded metal. Excessive static electricity may cause malfunction or trouble.
- Insert an SD card into the unit in the same orientation as pictured on the unit. Failure to do so may damage the SD card or the slot on the unit.
- The SD card access LED flashes red when the SD card is being accessed. Never remove the SD card or turn off power to the unit while the LED is flashing. Doing so may destroy the data on the SD card. Check that the LED has turned off before removing the SD card or turning off the power to the unit.

[General Notes]

- Never bundle control cables or input/output cables with high-voltage and large-current carrying cables such as power supply cables. Keep these cables at least 200 mm away from the high-voltage and large-current carrying cables. Otherwise, malfunction may occur due to noise.
- When using the V9 series in an environment where a source of high-frequency noise is present, it is recommended that the FG shielded cable (communication cable) be grounded at each end. However, when communication is unstable, select between grounding one or both ends, as permitted by the usage environment.
- Be sure to plug connectors or sockets of the V9 series in the correct orientation. Failure to do so may lead to damage or malfunction.
- If a LAN cable is inserted into the MJ1 or MJ2 connector on the V9 series, the counterpart device may be damaged. Check the indication on the unit and insert a cable into the correct position.
- Do not use thinners for cleaning because they may discolor the V9 series surface. Use commercially available alcohol.
- If a data receive error occurs when the V9 series and the counterpart (PLC, temperature controller, etc.) are started at the same time, read the manual for the counterpart unit and remove the error correctly.
- Avoid discharging static electricity on the mounting panel of the V9 series. Discharging static electricity on the mounting panel may cause malfunction due to noise.
- Avoid prolonged display of any fixed pattern. Due to the characteristic of liquid crystal displays, an afterimage may occur. If prolonged display of a fixed pattern is expected, use the backlight's auto OFF function.
- The V9 series is identified as a class-A product in industrial environments. In the case of use in a domestic environment, the unit is likely to cause electromagnetic interference. Preventive measures should thereby be taken appropriately.

[Notes on the LCD]

Note that the following conditions may occur under normal circumstances.

- The response time, brightness and colors of the V9 series may be affected by the ambient temperature.
- Tiny spots (dark or luminescent) may appear on the display due to the characteristics of liquid crystal.
- There are variations in brightness and colors between units.

Contents

1.	Overview	
1.1	System Configuration	1-1
1.1.1	Overview	1-1
1.1.2	System Composition	1-2
	Serial Communication	1-2
	Ethernet Communication	1-3
	Mixed Serial-Ethernet Communication	1-3
1.2	Physical Ports	1-4
1.2.1	CN1	1-4
1.2.2	MJ1/MJ2	1-5
1.2.3	LAN	1-6
1.2.4	Network Communication Port (Under Development)	1-6
1.2.5	USB	1-7
1.2.6	DIP Switch (DIPSW) Settings	1-7
1.3	Connection Methods	1-8
1.3.1	Serial Communication	1-8
	1 : 1 Connection	1-8
	1 : n Connection (Multi-drop)	1-14
	n : 1 Connection (Multi-link2) (Under Development)	1-17
	n : 1 Connection (Multi-link2 (Ethernet)) (Under Development)	1-25
	n : n Connection (1: n Multi-link2 (Ethernet)) (Under Development)	1-28
	n : 1 Connection (Multi-link) (Under Development)	1-31
1.3.2	Ethernet Communication	1-36
1.3.3	Network Communication (Under Development)	1-41
1.3.4	Slave Communication	1-42
	V-Link	1-42
	MODBUS RTU	1-42
	MODBUS TCP/IP	1-42
1.3.5	Other Connections	1-42
1.4	Hardware Settings	1-43
1.4.1	PLC Settings	1-43
	Selecting a Device to be Connected	1-44
	PLC Properties	1-44
1.4.2	MONITOUCH Settings	1-46
	Select Edit Model	1-46
	Control Area	1-47
	Buzzer	1-49
	Backlight	1-49
	Local IP Address	1-49
1.4.3	Other Equipment	1-52
	Printer	1-52
	Touch Switch (CH5)	1-54
	Simulator	1-54
1.5	System Device Memory for Communication Confirmation	1-55
1.5.1	\$Pn (For 8-way Communication)	1-55
1.5.2	\$s518 (Ethernet Status Confirmation)	1-63
2.	IAI	
2.1	Temperature Controller/Servo/Inverter Connection	2-1
	Serial Connection	2-1
2.1.1	X-SEL Controller	2-2
2.1.2	ROBO CYLINDER (RCP2/ERC)	2-12
2.1.3	ROBO CYLINDER (RCS/E-CON)	2-15
2.1.4	PCON / ACON / SCON (MODBUS RTU)	2-18
2.1.5	Wiring Diagrams	2-20
	When Connected at CN1:	2-20
	When Connected at MJ1/MJ2:	2-22

3.	IDEC	
3.1	PLC Connection	3-1
	Serial Connection	3-1
3.1.1	MICRO 3	3-2
3.1.2	MICRO Smart	3-3
3.1.3	MICRO Smart Pentra	3-4
3.1.4	Wiring Diagrams	3-6
	When Connected at CN1:	3-6
	When Connected at MJ1/MJ2:	3-9
4.	JTEKT	
4.1	PLC Connection	4-1
	Serial Connection	4-1
	Ethernet Connection	4-1
4.1.1	TOYOPUC	4-2
4.1.2	TOYOPUC (Ethernet)	4-5
4.1.3	TOYOPUC (Ethernet PC10 Mode)	4-7
4.1.4	Wiring Diagrams	4-11
	When Connected at CN1:	4-11
	When Connected at MJ1/MJ2:	4-11
5.	KEYENCE	
5.1	PLC Connection	5-1
	Serial Connection	5-1
	Ethernet Connection	5-1
5.1.1	KZ Series Link	5-2
5.1.2	KZ-A500 CPU	5-4
5.1.3	KV10/24 CPU	5-5
5.1.4	KV-700	5-6
5.1.5	KV-700 (Ethernet TCP/IP)	5-8
5.1.6	KV-1000	5-9
5.1.7	KV-1000 (Ethernet TCP/IP)	5-11
5.1.8	KV-3000 / 5000	5-12
5.1.9	KV-3000 / 5000 (Ethernet TCP/IP)	5-14
5.1.10	Wiring Diagrams	5-15
	When Connected at CN1:	5-15
	When Connected at MJ1/MJ2:	5-16
6.	KOGANEI	
6.1	Temperature Controller / Servo / Inverter	6-1
	Serial Connection	6-1
6.1.1	IBFL-TC	6-2
6.1.2	Wiring Diagrams	6-4
	When Connected at CN1:	6-4
	When Connected at MJ1/MJ2:	6-4
7.	KOYO ELECTRONICS	
7.1	PLC Connection	7-1
	Serial Connection	7-1
7.1.1	SU/SG	7-2
7.1.2	SR-T (K Protocol)	7-9
7.1.3	SU/SG (K-Sequence)	7-10
7.1.4	SU/SG (MODBUS RTU)	7-13
7.1.5	Wiring Diagrams	7-16
	When Connected at CN1:	7-16
	When Connected at MJ1/MJ2:	7-19

8.	LS	
8.1	PLC Connection	8-1
	Serial Connection	8-1
	Ethernet Connection	8-1
8.1.1	MASTER-KxxxS	8-2
8.1.2	MASTER-KxxxS CNET	8-3
8.1.3	GLOFA CNET	8-5
8.1.4	GLOFA GM7 CNET	8-7
8.1.5	GLOFA GM Series CPU	8-8
8.1.6	GLOFA GM Series (Ethernet UDP/IP)	8-9
8.1.7	XGT/XGK Series CNET	8-10
8.1.8	XGT/XGK Series CPU	8-12
8.1.9	XGT / XGK Series (Ethernet)	8-12
8.1.10	XGT / XGI Series CNET	8-13
8.1.11	XGT / XGI Series CPU	8-15
8.1.12	XGT / XGI Series (Ethernet)	8-17
8.1.13	Wiring Diagrams	8-18
	When Connected at CN1:	8-18
	When Connected at MJ1/MJ2:	8-20
9.	MITSUBISHI ELECTRIC	
9.1	PLC Connection	9-1
	Serial Connection	9-1
	Ethernet Connection	9-4
9.1.1	A Series Link	9-6
9.1.2	A Series CPU	9-8
9.1.3	QnA Series Link	9-9
9.1.4	QnA Series CPU	9-11
9.1.5	QnA Series (Ethernet)	9-12
9.1.6	QnH (Q) Series Link	9-15
9.1.7	QnH (Q) Series CPU	9-17
9.1.8	QnH (Q) Series (Ethernet)	9-18
9.1.9	QnU Series CPU	9-21
9.1.10	Q00J/00/01 CPU	9-21
9.1.11	QnH (Q) Series Link (Multi CPU)	9-21
9.1.12	QnH (Q) Series (Multi CPU) (Ethernet)	9-21
9.1.13	QnH (Q) Series CPU (Multi CPU)	9-21
9.1.14	QnH (Q) Series (Ethernet ASCII)	9-22
9.1.15	QnH (Q) Series (Multi-CPU) (Ethernet ASCII)	9-25
9.1.16	QnU Series (Built-in Ethernet)	9-26
9.1.17	L Series Link	9-29
9.1.18	L Series (Built-in Ethernet)	9-31
9.1.19	FX Series CPU	9-34
9.1.20	FX2N/1N Series CPU	9-35
9.1.21	FX1S Series CPU	9-36
9.1.22	FX Series Link (A Protocol)	9-37
9.1.23	FX-3U/3UC/3G Series CPU	9-39
9.1.24	FX-3U Series (Ethernet)	9-40
9.1.25	FX 3U/3UC/3G Series Link (A Protocol)	9-43
9.1.26	A-Link + Net10	9-45
9.1.27	Q170MCP (Multi CPU)	9-47
9.1.28	Q170 Series (Multi CPU) (Ethernet)	9-49
9.1.29	Wiring Diagrams	9-52
	When Connected at CN1:	9-52
	When Connected at MJ1/MJ2:	9-54
	V-MDD (Dual Port Interface)	9-57
9.2	Temperature Controller/Servo/Inverter	9-58
	Inverter	9-58
	Servo	9-58
9.2.1	FR-*500	9-59
9.2.2	FR-V500	9-62
9.2.3	MR-J2S-*A	9-65
9.2.4	MR-J3-*A	9-67
9.2.5	MR-J3-*T	9-69
9.2.6	FR-E700	9-72

9.2.7	Wiring Diagrams	9-76
	When Connected at CN1:	9-76
	When Connected at MJ1/MJ2:	9-77
10.	MODICON	
10.1	PLC Connection	10-1
	Serial Connection	10-1
10.1.1	Modbus RTU	10-2
10.1.2	Wiring Diagrams	10-3
	When Connected at CN1:	10-3
	When Connected at MJ1/MJ2:	10-3
11.	MOELLER	
11.1	PLC Connection	11-1
	Serial Connection	11-1
11.1.1	PS4	11-2
11.1.2	Wiring Diagrams	11-3
	When Connected at CN1:	11-3
	When Connected at MJ1/MJ2:	11-3
12.	M-SYSTEM	
12.1	Temperature Controller/Servo/Inverter Connection	12-1
	Remote I/O	12-1
12.1.1	R1M Series	12-2
12.1.2	Wiring Diagrams	12-3
	When Connected at CN1:	12-3
	When Connected at MJ1/MJ2:	12-4
13.	OMRON	
13.1	PLC Connection	13-1
	Serial Connection	13-1
	Ethernet Connection	13-3
13.1.1	SYSMAC C	13-4
13.1.2	SYSMAC CV	13-9
13.1.3	SYSMAC CS1/CJ1	13-12
13.1.4	SYSMAC CS1/CJ1 (DNA)	13-16
13.1.5	SYSMAC CS1/CJ1 (Ethernet)	13-18
13.1.6	SYSMAC CS1/CJ1 (Ethernet Auto)	13-20
13.1.7	SYSMAC CS1/CJ1 DNA (Ethernet)	13-22
13.1.8	Wiring Diagrams	13-25
	When Connected at CN1:	13-25
	When Connected at MJ1/MJ2:	13-27
13.2	Temperature Controller/Servo/Inverter Connection	13-29
	Temperature Controller	13-29
	ID Controller	13-29
	Power Meter	13-30
13.2.1	E5AK	13-31
13.2.2	E5AK-T	13-32
13.2.3	E5AN/E5EN/E5CN/E5GN	13-33
13.2.4	E5AR/E5ER	13-35
13.2.5	E5CK	13-38
13.2.6	E5CK-T	13-39
13.2.7	E5CN-HT	13-40
13.2.8	E5EK	13-42
13.2.9	E5ZD	13-43
13.2.10	E5ZE	13-45
13.2.11	E5ZN	13-48
13.2.12	V600/620/680	13-50
13.2.13	KM20	13-57
13.2.14	KM100	13-59
13.2.15	Wiring Diagrams	13-61
	When Connected at CN1:	13-61
	When Connected at MJ1/MJ2:	13-63

14.	Oriental Motor	
14.1	Temperature Controller / Servo / Inverter Connection	14-1
	Stepping Motor	14-1
14.1.1	High-efficiency AR Series (MODBUS RTU)	14-2
14.1.2	CRK Series (MODBUS RTU)	14-4
14.1.3	Wiring diagram	14-6
	When Connected at CN1:	14-6
	When Connected at MJ1/MJ2:	14-6
15.	Panasonic	
15.1	PLC Connection	15-1
	Serial Connection	15-1
	Ethernet Connection	15-2
15.1.1	FP Series (RS232C/422)	15-3
15.1.2	FP Series (TCP/IP)	15-7
15.1.3	FP Series (UDP/IP)	15-10
15.1.4	FP-X (TCP/IP)	15-13
15.1.5	FP7 Series (RS232C/422)	15-16
15.1.6	FP7 Series (Ethernet)	15-19
15.1.7	Wiring Diagrams	15-22
	When Connected at CN1:	15-22
	When Connected at MJ1/MJ2:	15-24
15.2	Temperature Controller/Servo/Inverter Connection	15-26
	Serial Connection	15-26
15.2.1	LP-400 Series	15-27
15.2.2	KW Series	15-63
15.2.3	MINAS A4 Series	15-66
15.2.4	Wiring Diagrams	15-69
	When Connected at CN1:	15-69
	When Connected at MJ1/MJ2:	15-71
16.	RKC	
16.1	Temperature Controller/Servo/Inverter Connection	16-1
	Serial Connection	16-1
16.1.1	CB100/CB400/CB500/CB700/CB900 (MODBUS RTU)	16-3
16.1.2	SRV (MODBUS RTU)	16-4
16.1.3	SR-Mini (MODBUS RTU)	16-5
16.1.4	SR-Mini (Standard Protocol)	16-6
16.1.5	REX-F400/F700/F900 (Standard Protocol)	16-7
16.1.6	MA900 / MA901 (MODBUS RTU)	16-8
16.1.7	SRZ (MODBUS RTU)	16-9
16.1.8	FB100/FB400/FB900 (MODBUS RTU)	16-10
16.1.9	Wiring Diagrams	16-12
	When Connected at CN1:	16-12
	When Connected at MJ1/MJ2:	16-14
17.	RS Automation	
17.1	PLC Connection	17-1
	Serial Connection	17-1
	Ethernet Connection	17-2
17.1.1	NX7/NX Plus Series (70P/700P/CCU+)	17-3
17.1.2	N7/NX Series (70/700/750/CCU)	17-6
17.1.3	X8 Series	17-7
17.1.4	NX700 Series (Ethernet)	17-11
17.1.5	X8 Series (Ethernet)	17-14
17.1.6	Wiring Diagrams	17-16
	When Connected at CN1:	17-16
	When Connected at MJ1/MJ2:	17-20

Connection Compatibility List

1. Overview

- 1.1 System Configuration
- 1.2 Physical Ports
- 1.3 Connection Methods
- 1.4 Hardware Settings
- 1.5 System Device Memory for Communication Confirmation

1.1 System Configuration

1.1.1 Overview

The V9 series is equipped with seven physical ports consisting of three serial ports, one LAN port, one USB-A port, one USB mini-B port, and one network communication port *1. The LAN port can open eight ports simultaneously. You can use the physical ports to connect a maximum of eight different models of devices and allow the V9 series to communicate with them at the same time. This is called 8-way communication.

*1 A communication interface unit (CUR-xx, under development) is required to enable network communication.

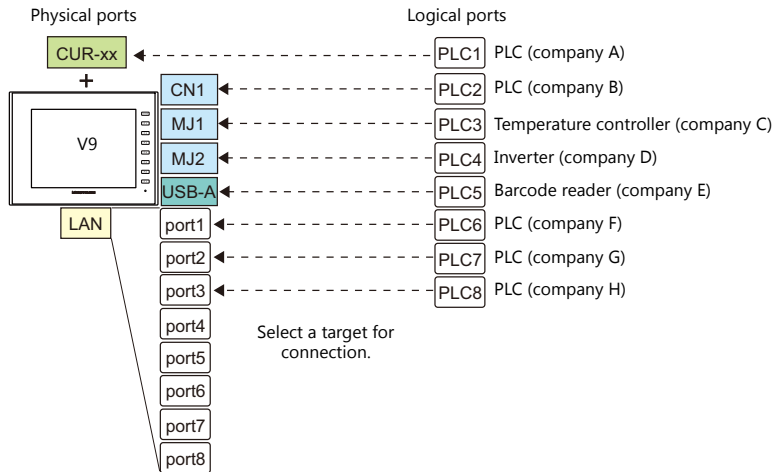

Physical Ports		No. of Ports	Applicable Devices	
			8-way Communication	Other than 8-way
Serial	CN1 (RS-232C/RS-422/485)	1	PLC, temperature controller, servo, inverter, barcode reader	-
	MJ1 (RS-232C/RS-485, 2-wire connection)	1	PLC, temperature controller, servo, inverter, barcode reader, V-Link, slave communication (Modbus RTU)	Computer (screen program transfer, MJ1) Serial printer
	MJ2 (RS-232C/RS-485, 2-wire connection)	1		
Ethernet	LAN	8	PLC, slave communication (Modbus TCP/IP)	Computer (screen program transfer)
USB	USB-A	1	Barcode reader	Printer (EPSON ESC/P-R compatible), USB flash drive, USB-CFREC-2 (under development), keyboard, mouse, USB hub
	USB mini-B	1	-	Printer (PictBridge), computer (screen program transfer)
Network	OPCN-1	1	PLC	-
	T-Link			
	CC-LINK			
	Ethernet			
	PROFIBUS-DP			
	SX BUS			
	DeviceNet			
	FL-Net			

- Only the logical port PLC1 can be selected for the following devices and functions. Thus, they cannot be connected at the same time.
 - Devices
Network connection (CUR-xx, under development), without PLC connection, Mitsubishi Electric A-Link + Net10, AB Control Logix, Siemens S7-200PPI, Siemens S7-300/400 MPI connection
 - Functions
Multi-link2, Multi-link, ladder transfer, ladder monitor, MICREX SX variable name cooperation function

1.1.2 System Composition

Serial Communication

- **1 : 1 Connection**
A communication port is selectable from CN1, MJ1, and MJ2.
For more information, refer to "1 : 1 Connection" (page 1-8) in "1.3 Connection Methods".



- **1 : n Connection**
A communication port is selectable from CN1, MJ1, and MJ2. A maximum of 31 units of the same model can be connected to each port.
For more information, refer to "1 : n Connection (Multi-drop)" (page 1-14) in "1.3 Connection Methods".

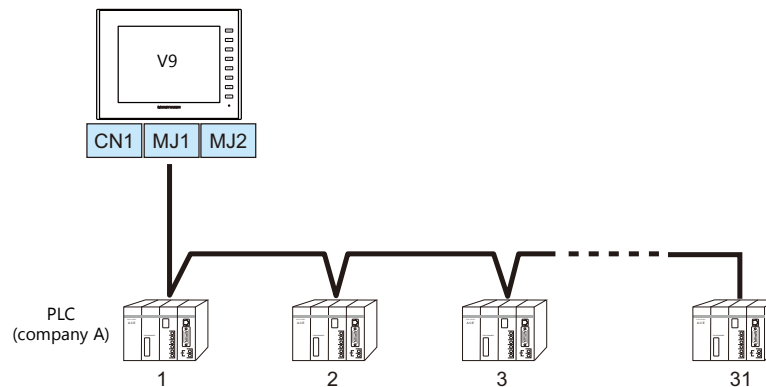

- **3-way Connection**
The V9 series is allowed to communicate with three different models of devices at the same time via three serial ports. A maximum of 31 units of the same model can be connected to each port.
The connection method is the same as those for 1 : 1 and 1 : n.

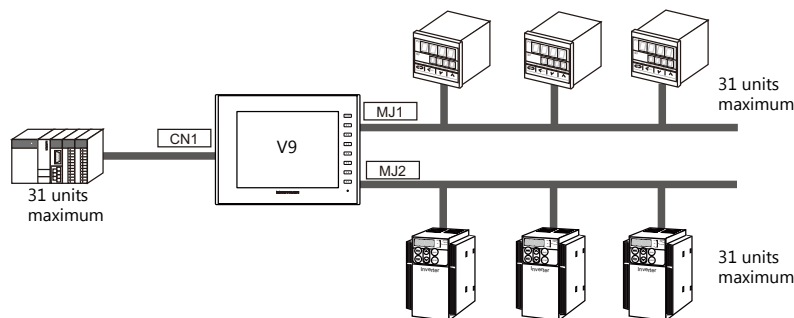

- **n : 1 Connection (Under development)**
Multiple V9 units can be connected to one PLC or temperature controller.
For more information, refer to "n : 1 Connection (Multi-link2) (Under Development)" (page 1-17), "n : 1 Connection (Multi-link2 (Ethernet)) (Under Development)" (page 1-25), "n : 1 Connection (Multi-link) (Under Development)" (page 1-31) in "1.3 Connection Methods".
- **n : n Connection (Under development)**
Multiple V9 units can be connected to multiple PLCs.
For more information, refer to "n : n Connection (1: n Multi-link2 (Ethernet)) (Under Development)" (page 1-28) in "1.3 Connection Methods".

Ethernet Communication

Because eight communication ports can be opened, the V9series is allowed to communicate with eight models of PLCs at the same time.

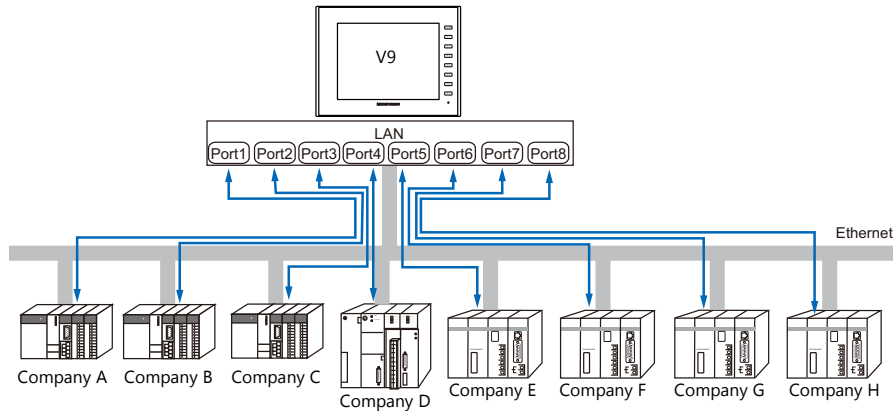

When there are two or more PLCs of the same model, the V9 series is allowed to carry out 1 : n communication via one port.

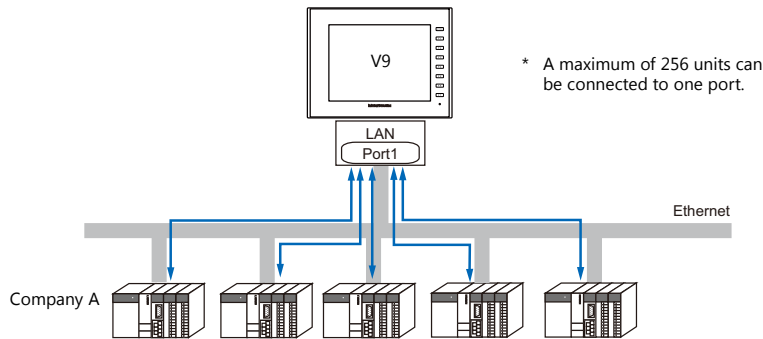

* A maximum of 256 units can be connected to one port.

* For more information, refer to "1.3.2 Ethernet Communication" (page 1-36) in "1.3 Connection Methods".

Mixed Serial-Ethernet Communication

In the case of mixed serial-Ethernet communication, the V9 series is allowed to communicate with eight different models of devices at the same time.

- Connection of 3 models for serial communication and 5 models for Ethernet communication

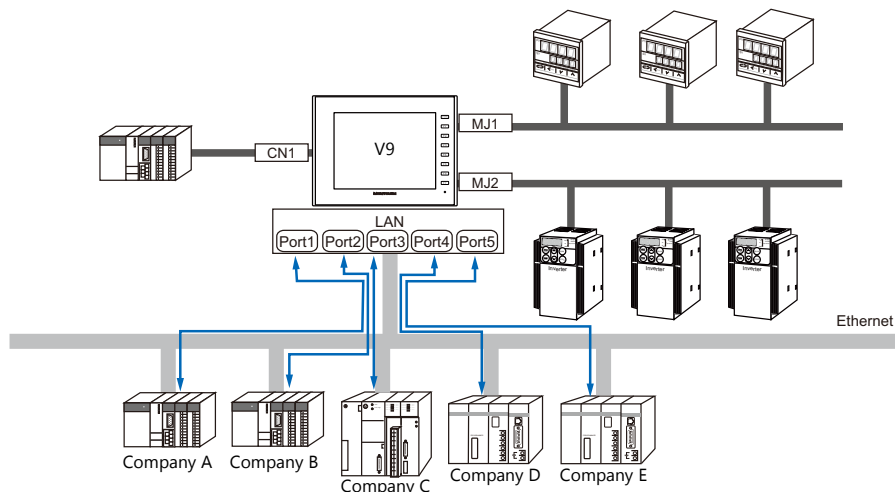

* For the connection method, refer to "1.3.1 Serial Communication" and "1.3.2 Ethernet Communication".

1.2 Physical Ports

1.2.1 CN1

The CN1 port supports communication via RS-232C, RS-422 (4-wire system), and RS-485 (2-wire system). The signal level can be changed between RS-232C and RS-422/485 under [Communication Setting] of the editor.

* The signal level can be changed between RS-232C and RS-422/485 in the Local mode on the V9 unit as well. For details, refer to the separate V9 Series Hardware Specifications manual.



CAUTION

When executing communication via RS-232C, set the DIP switches 5 and 7 to OFF. For more information on the DIP switch, refer to "1.2.6 DIP Switch (DIPSW) Settings" (page 1-7).

Pin Arrangement

CN1 Dsub 9pin, Female	No.	RS-232C		RS-422/RS-485	
		Name	Contents	Name	Contents
	1	NC	Not used	+RD	Receive data (+)
	2	RD	Receive data	-RD	Receive data (-)
	3	SD	Send data	-SD	Send data (-)
	4	NC	Not used	+SD	Send data (+)
	5	0V	Signal ground	0V	Signal ground
	6	NC	Not used	+RS	RS send data (+)
	7	RS	RS request to send	-RS	RS send data (-)
	8	CS	CS clear to send	NC	Not used
	9	NC	Not used	+5V	Terminating resistance

Recommended Connector for Communication Cable

Recommended Connector	
DDK's 17JE-23090-02(D8C)-CG	D-sub 9-pin, male, inch screw thread, with hood, RoHS compliant

Applicable Devices

Applicable Devices
PLC, temperature controller, inverter, servo, barcode reader

1.2.2 MJ1/MJ2

The MJ1 and MJ2 ports support communication via RS-232C and RS-485 (2-wire system). MJ1 is also usable as a screen program transfer port.

CAUTION

- MJ1 and MJ2 use the same type RJ-45 connector as the LAN connector. To prevent damage to the device from an external power supply of the MJ, check the indication on the unit and insert a cable in the correct position.
- MJ1 and MJ2 are not usable for connection via RS-422 (4-wire system). Use the CN1 port instead or a commercially available RS-232C-to-RS-422 converter.

Pin Arrangement

MJ1/MJ2

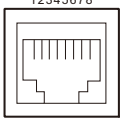
MJ1/MJ2 RJ-45 8pin	No.	Signal	Contents
	1	+SD/RD	RS-485 + data
	2	-SD/RD	RS-485 - data
	3	+5V	Externally supplied +5 V*
	4		
	5	SG	Signal ground
	6		
	7	RD	RS-232C receive data
	8	SD	RS-232C send data

* For MJ1, MJ2 and USB A, the maximum allowable current is 150 mA in total (only when the installation angle of MONITOUCH is within 60° to 120°).

Recommended Cable

Recommended Cable
Hakko Electronics' cable "V6-TMP" 3, 5, 10 m

Notes on Configuring a Cable

CAUTION

Pins No. 3 and 4 are provided for external power supply. To prevent damage to the device due to wrong connection, check the pin numbers and connect wires correctly.

Pin arrangement
on MONITOUCH

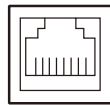

87654321

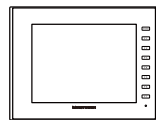

Pin arrangement
on the cable



12345678



Applicable Devices

Port	Applicable Devices
MJ1	Computer (screen program transfer)
	PLC, temperature controller, inverter, servo, barcode reader, V-Link, slave communication (Modbus RTU), serial printer
MJ2	PLC, temperature controller, inverter, servo, barcode reader, V-Link, slave communication (Modbus RTU), serial printer

1.2.3 LAN



The LAN connector uses the same type RJ-45 connector as MJ1 and MJ2. Check the indication on the unit and insert a cable into the correct position.

LAN Port Specifications

Item	Specifications	
	100BASE-TX (IEEE802.3u)	10BASE-T (IEEE802.3)
Baud Rate	100 Mbps	10 Mbps
Transmission method	Base band	
Maximum segment length	100 m (between the node and the hub)	
Connecting cable	100 Ω, UTP cable, category 5	
Protocol	UDP/IP, TCP/IP	
Port	Auto-MDIX, Auto-Negotiation functions compatible	
Number of concurrently opened ports	8 ports	
Maximum number of connectable devices	256 sets each via one single port PLC1 - PLC8	

Maximum number of connectable devices

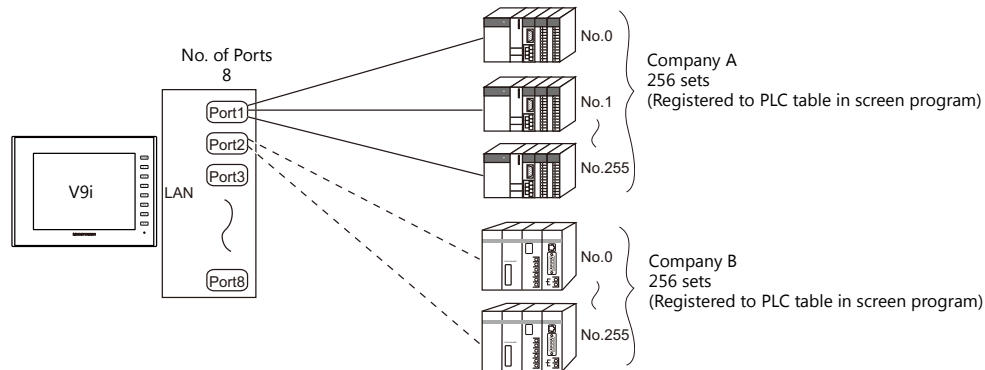

Pin Arrangement

LAN RJ-45	No.	Name	Contents
	1	TX+	Send signal +
	2	TX-	Send signal -
	3	RX+	Receive signal +
	4	NC	Not used
	5		
	6	RX-	Receive signal -
	7	NC	Not used
	8		

Applicable Devices



Applicable Devices
PLC, slave communication (Modbus TCP/IP), computer (screen program transfer, V-Server, etc.)

1.2.4 Network Communication Port (Under Development)

An optional communication interface unit "CUR-xx" (under development) is required to perform network communication. For more information, refer to the specifications for each unit.

1.2.5 USB

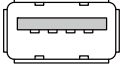
USB Port Specifications

Item		Specifications
USB-A 	Applicable standards	USB versions 2.0
USB mini-B 	Baud Rate	High-speed 480 Mbps

Applicable Devices

Port	Applicable Devices
USB-A	Printer (EPSON ESC/P-R compatible), barcode reader, USB flash drive, USB-CFREC-2 (under development), numeric keypad, keyboard, mouse, USB hub
USB mini-B	Printer (PictBridge), computer (screen program transfer)

1.2.6 DIP Switch (DIPSW) Settings

The V9 series is equipped with DIP switches 1 to 8. When setting the DIP switch, turn the power off.

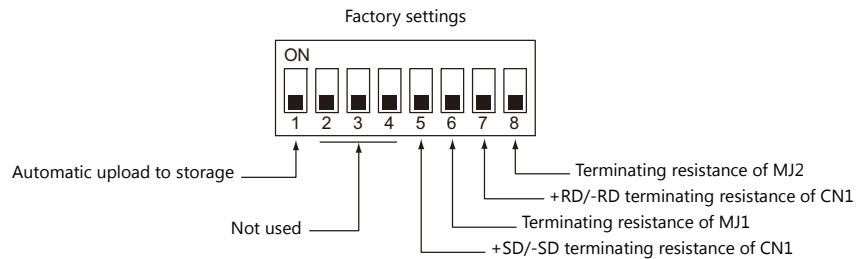

DIPSW1* (Automatic upload to storage)

Set the DIPSW1 to ON when automatically uploading screen programs from storage such as an SD card or USB flash drive. For details, refer to the separate V9 Series Hardware Specifications manual.

* Be sure to set the DIPSW1 to OFF when automatic upload is not performed.

DIPSW5, 6, 7, 8 (Terminating resistance setting)

- When connecting a controller to CN1 via RS-422/485 (2-wire connection), set the DIPSW7 to ON.
- When connecting a controller to CN1 via RS-422/485 (4-wire connection), set the DIPSW5 and DIPSW7 to ON.
- When connecting a controller at MJ1 via RS-422/485 (2-wire connection), set the DIPSW6 to ON.
- When connecting a controller at MJ2 via RS-422/485 (2-wire connection), set the DIPSW8 to ON.



CAUTION

When executing communication via RS-232C at CN1, set the DIP switches 5 and 7 to OFF.

1.3 Connection Methods

1.3.1 Serial Communication

1 : 1 Connection

Overview

- One set of the V9 is connected to one PLC (1 : 1 connection).
- You can make settings for 1 : 1 communication in [Communication Setting] for the logical ports PLC1 - PLC8. A communication port is selectable from CN1, MJ1, and MJ2.



RS-232C or RS-422 (RS-485) connection
 Maximum length of wiring
 RS-232C connection: 15 m
 RS-422/RS-485 connection: 500 m

* The maximum length of wiring varies depending on the connected device.
 Check the specifications for each device.

- The V9 (master station) communicates with a PLC under the PLC's protocol. Therefore, there is no need to prepare a communication program for the PLC (slave station).
- The V9 reads from the PLC device memory for screen display. It is also possible to write switch data or numerical data entered through the keypad directly to the PLC device memory.

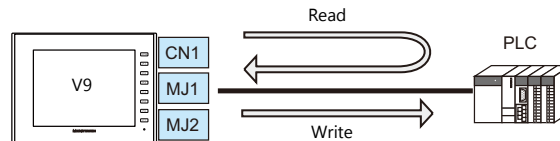

V-SFT Ver. 6 Settings

Hardware Settings

Selecting a device to be connected

Select the device for connection from [System Setting] → [Hardware Setting].

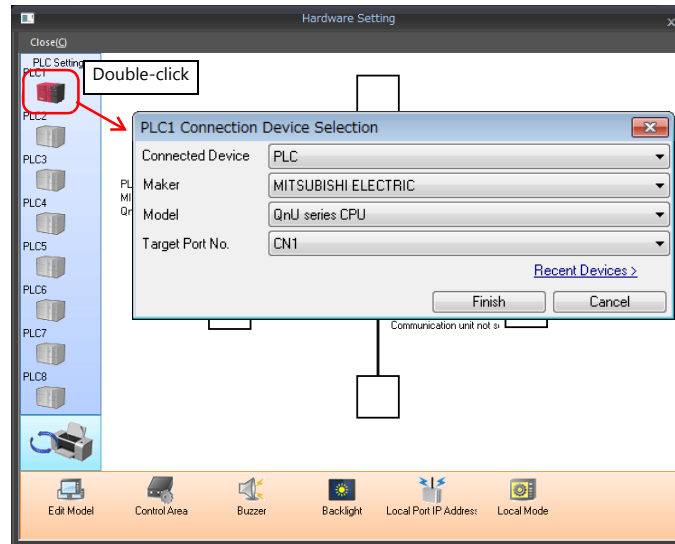

PLC properties

Configure [Communication Setting] on the [PLC Properties] window.

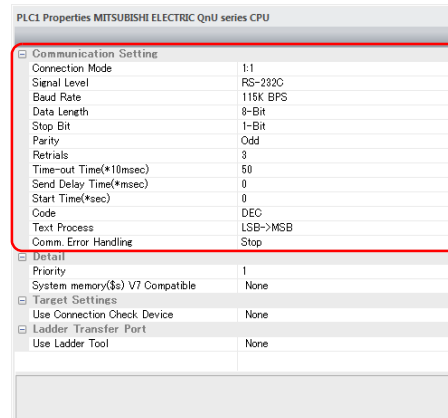

Item	Contents
Connection Mode	1 : 1
Signal Level	Configure according to the connected device.
Baud Rate	
Data Length	
Stop Bit	
Parity	
Target Port No.	
Transmission Mode	

For settings other than the above, see "1.4 Hardware Settings" (page 1-43).

Settings of a Connected Device

Refer to the chapter of the respective manufacturer.
For descriptions of connecting PLCs, refer to the manual for each PLC.

Wiring



DANGER

Be sure to turn off the power before connecting cables. Otherwise, electrical shock or damage may occur.

CN1

RS-232C connection

- Prepare a communication cable on your side. Twisted pairs of 0.3 mm sq. or above are recommended.
- The maximum length for wiring is 15 m.
 - * The maximum length varies depending on the connected device. Check the specifications for each device.
- Connect a shielded cable to either the V9 series or the connected device. The connection diagram shows the case where the shielded cable is connected on the V9 series side. Connect the cable to the FG terminal on the backside of MONITOUCH.

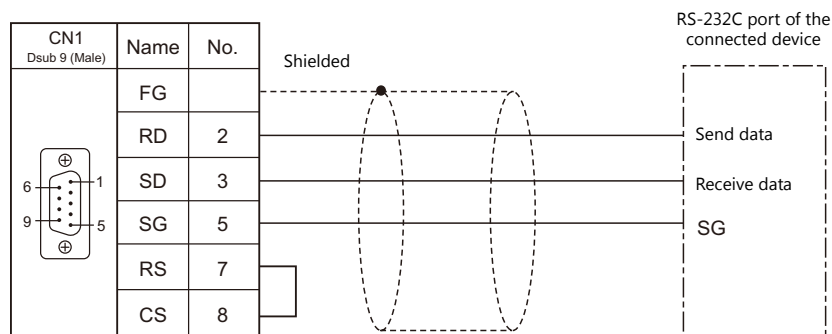

- If noise disturbs communications, establish connections between SD and SG and between RD and SG as pairs respectively, and connect a shielded cable to both the V9 series and the connected device.

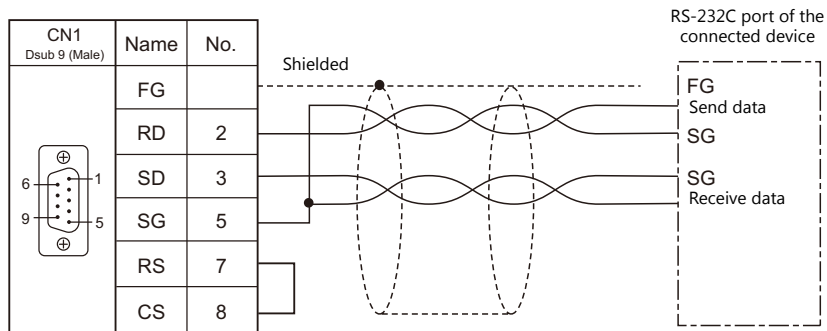

RS-422/RS-485 connection

- Prepare a communication cable on your side. Twisted pairs of 0.3 mm sq. or above are recommended.
- The maximum length of wiring is 500 m.
 - * The maximum length varies depending on the connected device. Check the specifications for each device.
- Connect twisted pairs between +SD and –SD, and between +RD and –RD.
- If the PLC has a signal ground (SG) terminal, connect it.
- To use a terminal block for connection, use Hakko Electronics' optionally available "TC-D9".
- The DIP switch on the back of the V9 unit is used to set the terminating resistance. For more information on DIP switches, refer to "1.2.6 DIP Switch (DIPSW) Settings" (page 1-7).
- Connect a shielded cable to either the V9 series or the connected device. The connection diagram shows the case where the shielded cable is connected on the V9 series side. Connect the cable to the FG terminal on the backside of MONITOUCH.
 - RS-422 (4-wire system)

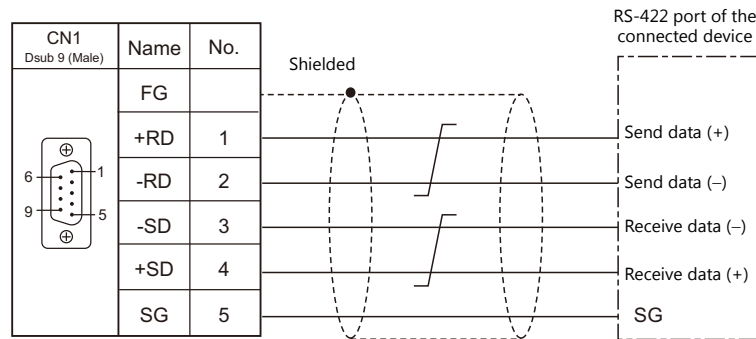

- RS-485 (2-wire system)

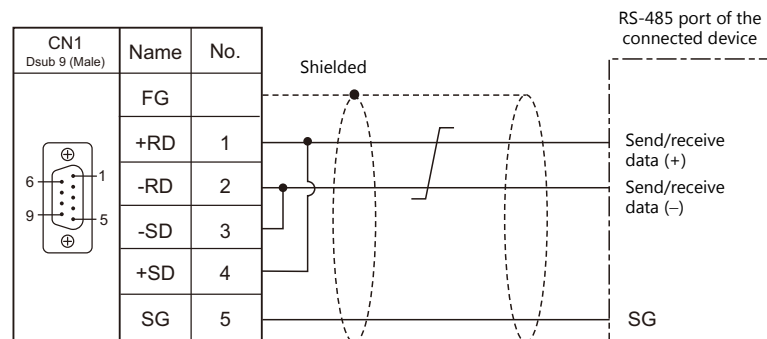

- If noise disturbs communications, connect a shielded cable to both the V9 series and the connected device.

- RS-422 (4-wire system)

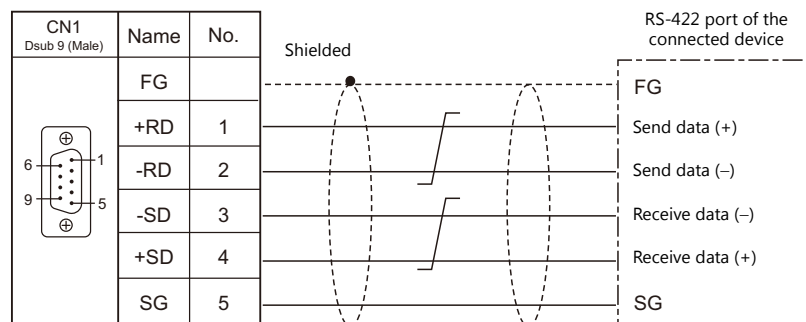

- RS-485 (2-wire system)

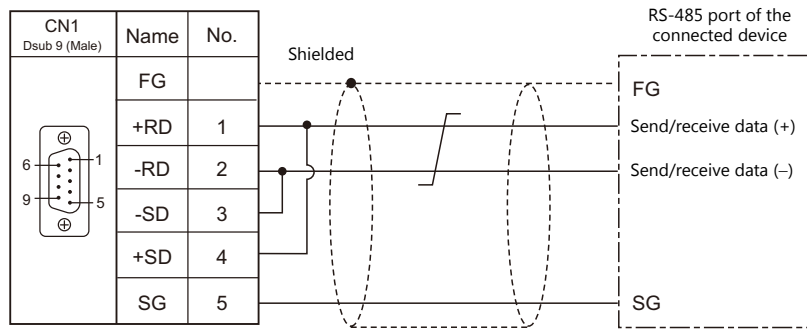

MJ1/MJ2

RS-232C connection

- Use Hakko Electronics' cable "V6-TMP" (3, 5, 10 m) as a communication cable.
- The maximum length of wiring is 15 m.
 - * The maximum length varies depending on the connected device. Check the specifications for each device.
- Connect a shielded cable to either the V9 series or the connected device. Connect the cable to the FG terminal on the backside of MONITOUCH.

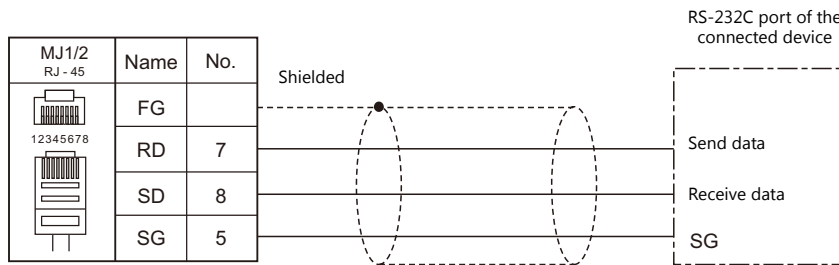

- If noise disturbs communications, connect a shielded cable to both the V9 series and the connected device.

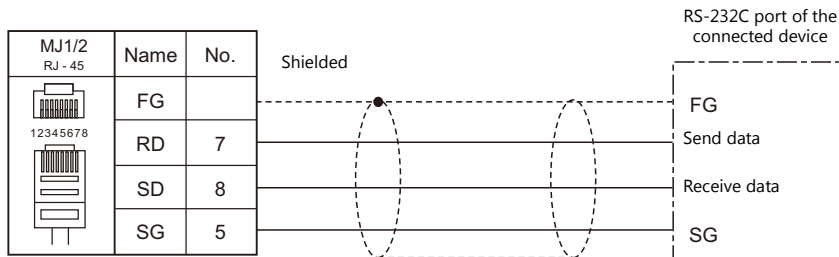

RS-485 (2-wire system) connection

The MJ1 and MJ2 are not usable for connection via RS-422 (4-wire system). Use the CN1 port instead or a commercially available RS-232C-to-RS-422 converter.

- Use Hakko Electronics' cable "V6-TMP" (3, 5, 10 m) as a communication cable.
- The maximum length of wiring is 500 m.
 - * The maximum length varies depending on the connected device. Check the specifications for each device.
- If the PLC has a signal ground (SG) terminal, connect it.
- The DIP switch on the back of the V9 unit is used to set the terminating resistance. For more information, see "1.2.6 DIP Switch (DIPSW) Settings" (page 1-7).
- Connect a shielded cable to either the V9 series or the connected device. Connect the cable to the FG terminal on the backside of MONITOUCH.

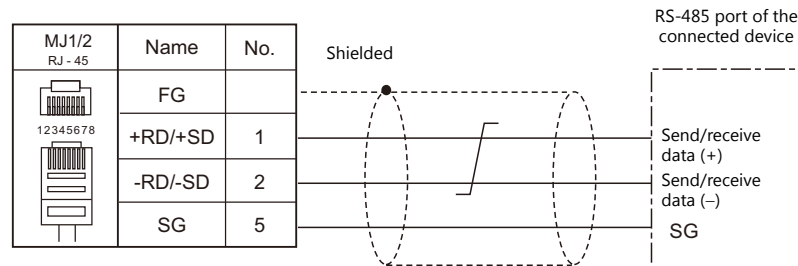

- If noise disturbs communications, connect a shielded cable to both the V9 series and the connected device.

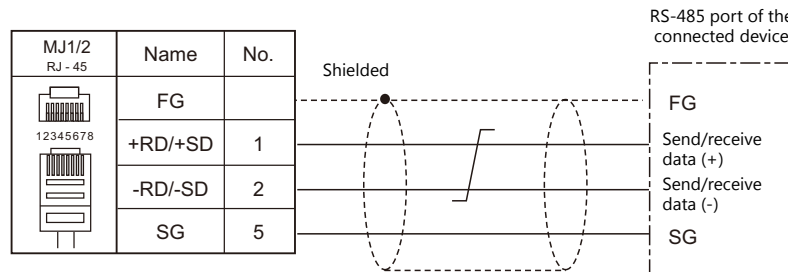

1 : n Connection (Multi-drop)

Overview

- Multi-drop connection connects one V9 unit to multiple PLCs of the same model as a 1 : n connection. (Maximum connectable units: 31)
- You can make settings for 1 : n communication in [Communication Setting] for the logical ports PLC1 - PLC8. A communication port is selectable from CN1, MJ1, and MJ2.

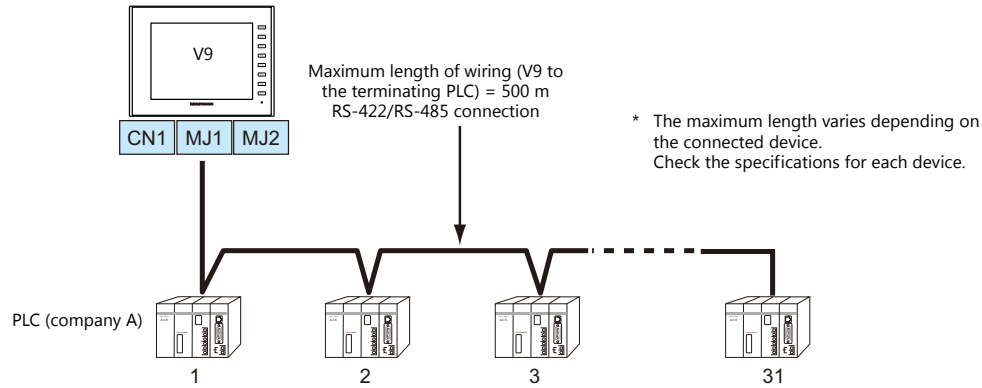

- The ladder transfer function is not available for a 1 : n connection.
- For models that support multi-drop connection, refer to the Connection Compatibility List provided at the end of this manual or the chapters on individual manufacturers.

V-SFT Ver. 6 Settings

Hardware Settings

Selecting a device to be connected

Select the device for connection from [System Setting] → [Hardware Setting].

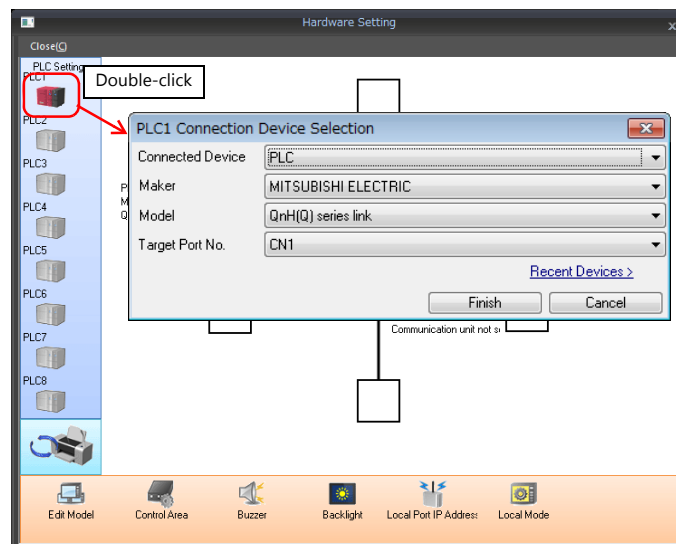

PLC properties

Configure [Communication Setting] on the [PLC Properties] window.

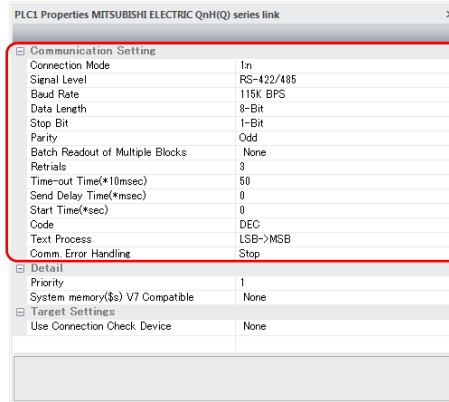

Item	Contents
Connection Mode	1 : n
Signal Level	RS-422/485
Baud Rate	Configure according to the connected device.
Data Length	
Stop Bit	
Parity	
Target Port No.	
Transmission Mode	

For settings other than the above, see "1.4 Hardware Settings" (page 1-43).

Settings of a Connected Device

Refer to the chapter of the respective manufacturer.
For descriptions of connecting PLCs, refer to the manual for each PLC.

Wiring



DANGER

Be sure to turn off the power before connecting cables. Otherwise, electrical shock or damage may occur.

CN1

The wiring between a V9 and a connected device is the same as that for 1 : 1 communication. For description of wiring between connected devices, refer to the manuals issued by the manufacturers.

RS-422 (4-wire system) connection

- Connection example

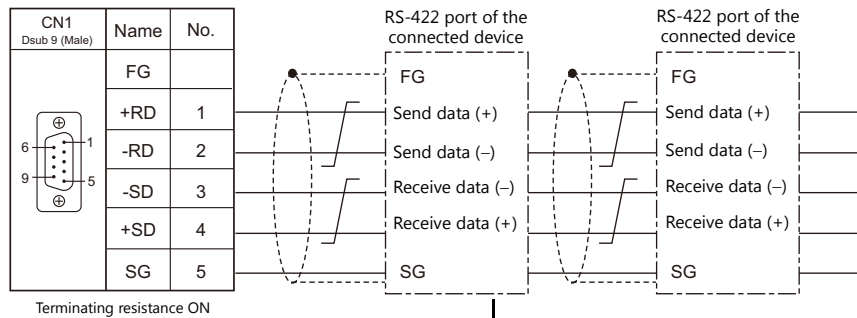

For wiring between connected devices, refer to the manuals issued by the manufacturers.

RS-485 (2-wire system) connection

- Connection example

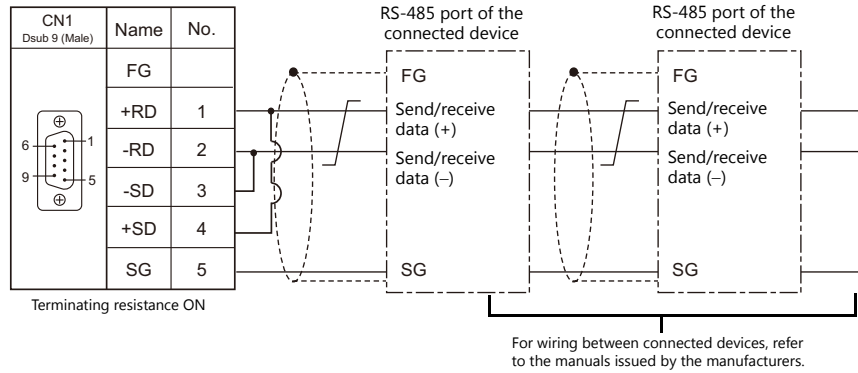

MJ1/MJ2

The wiring between a V9 and a connected device is the same as that for 1 : 1 communication. For description of wiring between connected devices, refer to the manuals issued by the manufacturers.

RS-485 (2-wire system) connection

- Connection example

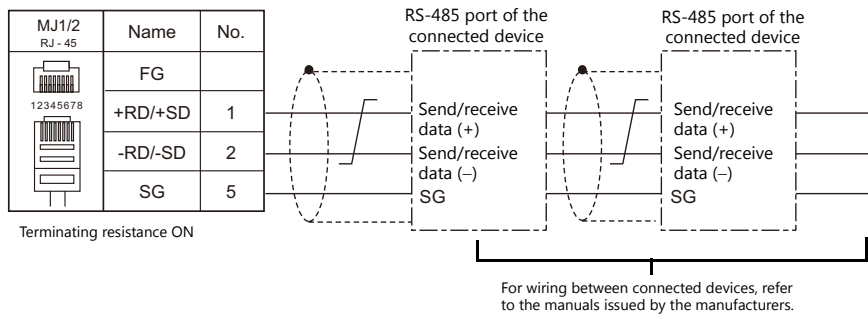

n : 1 Connection (Multi-link2) (Under Development)

Overview

- One PLC is connected to a maximum of four V9 units. The V8, V7, and V6 series can be used together.
- Multi-link2 enables you to establish an original network consisting of a master V9 of local port No. 1 and slave V9 units of local port Nos. 2, 3, and 4. The master V9 communicates with the PLC directly, and the slave V9 units communicate with the PLC through the master.
 - Connection example 1:

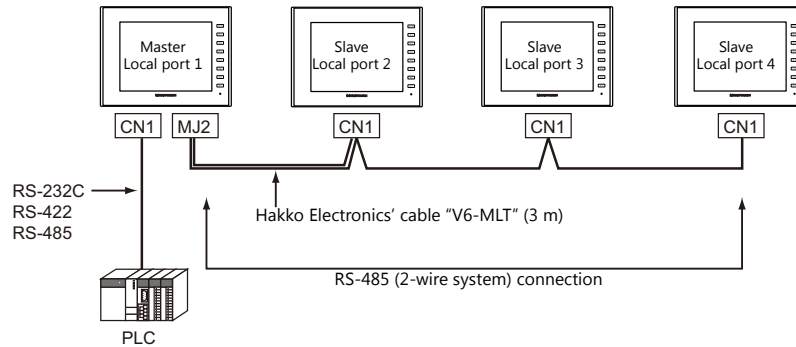

- Connection example 2:

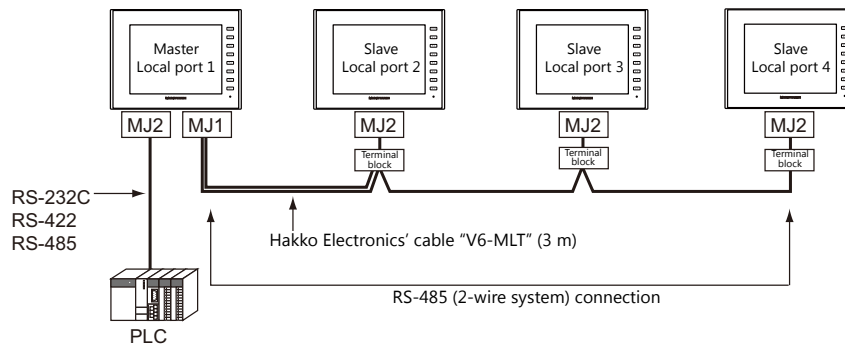

- You can make settings for multi-link2 in [Communication Setting] for PLC1. Therefore, multi-link2 connection is not possible concurrently with a network connection that uses a "CUR-xx" communication interface unit (under development).
- Multi-link2 enables sharing of data stored in PLC1 device memory among the V9 units. However, sharing data in PLC2 - PLC8 is not possible.
- The communication speed between the master and the PLC depends on the setting made on the PLC. The maximum communication speed between V9 units is 115 kbps, which is higher than the one available with multi-link connection described in "n : 1 Connection (Multi-link) (Under Development)".
- For PLCs that support multi-link2 connection, see Connection Compatibility List provided at the end of this manual. The connection between the master and the PLC is the same as the one for 1 : 1 connection. RS-485 (2-wire system) connection is adopted to connect a master with slaves. At this time, use Hakko Electronics' cable "V6-MLT" for the multi-link2 master.
- When connecting the V6 series together with the V9 series, note the following points:
 - When V609E, V606e, V606, or V606i is connected as a master, only V609E, V606e, V606, or V606i can be connected as a slave. The V9 series cannot be used as a slave in this case.
 - Multi-link2 cannot be used for the V6 series with which temperature control network/PLC2Way is used.
 - Multi-link2 may not be used on the V6 series depending on its hardware version. For more information, refer to the V6 Series Hardware Specifications manual.
- If the master station becomes faulty (communication error), the master and slave stations do not work, and as a result, "Communication Error Time-Out" is displayed. If a slave station becomes faulty, "Data Loading..." is displayed due to a communication error only on the faulty station.
- The ladder transfer function is not available for a multi-link2 connection.

V-SFT Ver. 6 Settings

Make settings on [Hardware Setting] → [PLC Properties]. The differences with respect to a 1 : 1 connection and the points where caution is required are explained here.
 For details on other settings, refer to Hardware Settings in "1 : 1 Connection" (page 1-8).

PLC Properties

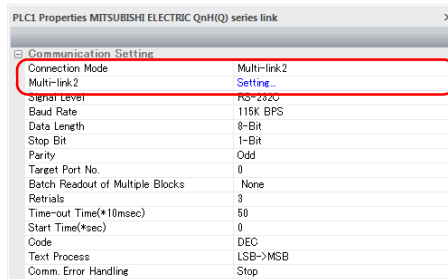

Item	Contents	
Communication Setting	Connection Mode	Multi-link2
	Multi-link2	Click [Setting] to display the [Multi-link] dialog, then make the necessary settings in this dialog. For more information on settings, see "Multi-link2" (page 1-18).

Multi-link2

For a master, set all of the items. For a slave, set only those items marked "♦".

- Master

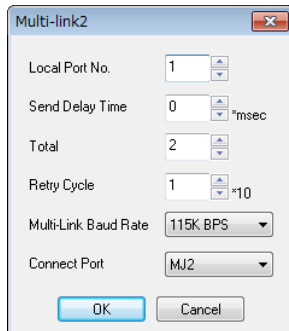

- Slave

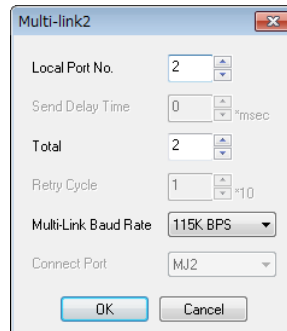

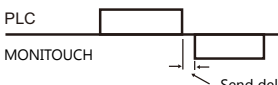
Local Port No. ♦	1 to 4 Specify a port number of the V9. For the master set "1", and for the slaves set "2" to "4". Note that if the port number specified is the same as that already set for another V9 unit, the system will not operate correctly.
Send Delay Time	Specify a delay time that elapses before V9 sends the next command after receiving data from the PLC. Normally use the default setting (0). 
Total ♦	2 to 4 Set the total number of V9 units connected in the multi-link2 connection. The setting must be the same as other V9 series on the same communication line.
Retry Cycle	Set the number of cycles before the master sends an inquiry for restoration to a slave that has a communication problem (= system down). When a slave has a problem, it is temporarily removed from the communication targets, and the master sends an inquiry for restoration every number of cycles specified for [Retry Cycle]. This setting does not affect the communication speed if no problem is occurring on the slave; however, if there is any problem, it does affect the communication speed. When the setting value is small: Restoration will not take long. When the setting value is large: Restoration will take a longer time.
Multi-Link Baud Rate ♦	4800/9600/19200/38400/57600/115 Kbps Set the baud rate for between V9 series units. The setting must be the same as other V9 series on the same communication line.
Connect Port	CN1/MJ1/MJ2 Set the port to be connected to slaves.

System Configurations and Wiring Diagrams

Connection Method 1

Connecting the MJ1/MJ2 of the master to CN1 connectors of the slaves

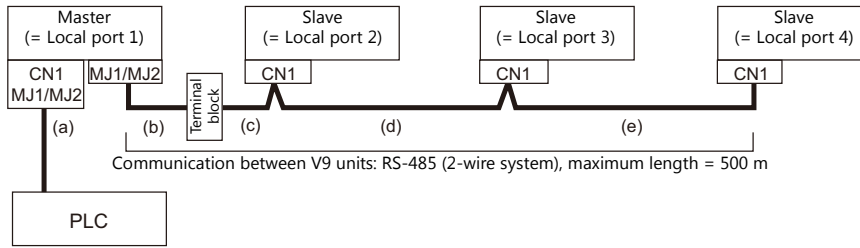

- (a) Connection between master and PLC
Select the port for connection from among CN1, MJ1 and MJ2.
The communication settings and connection method are the same as those for 1 : 1 connection.
- (b), (c) Connection between master and slave
Choose the connecting port of the master between MJ1 and MJ2.
The connecting port of the slave should be CN1. It is convenient to install the optional terminal converter "TC-D9".
Use the "V6-MLT" cable (3 m). If the distance is greater than 3 meters the customer should prepare a terminal block and extension cable (c), and should make the connection through that terminal block.
- (d), (e) Connection between slaves
Use the RS-485 (2-wire system) connection. It is convenient to install the optional terminal converter "TC-D9".
Use twisted-pair cables of 0.3 mm sq or greater.
- (b), (c), (d), (e) The maximum length of the wiring among the master and slave is 500 m.

Wiring diagrams

- When a TC-D9 is used:
Set the slide switch of "TC-D9" to ON (2-wire system).

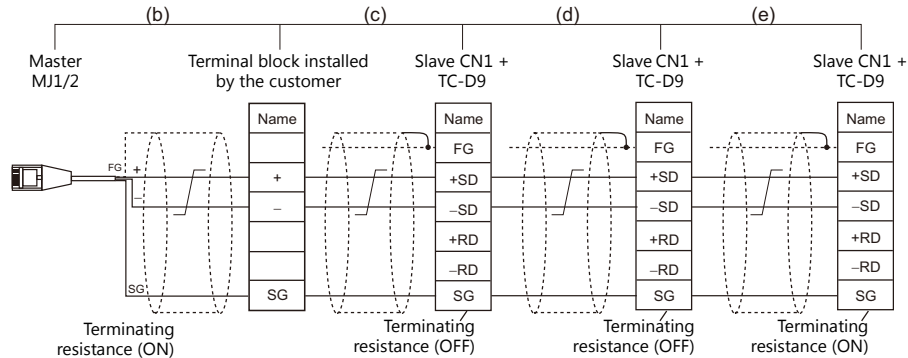

* As a measure against noise, connect the frame ground terminal of each V9 series at one side only. The frame ground of V6-MLT must be connected to the V9 series.

- When no TC-D9 is used:
Install jumpers between +SD and +RD as well as -SD and -RD.

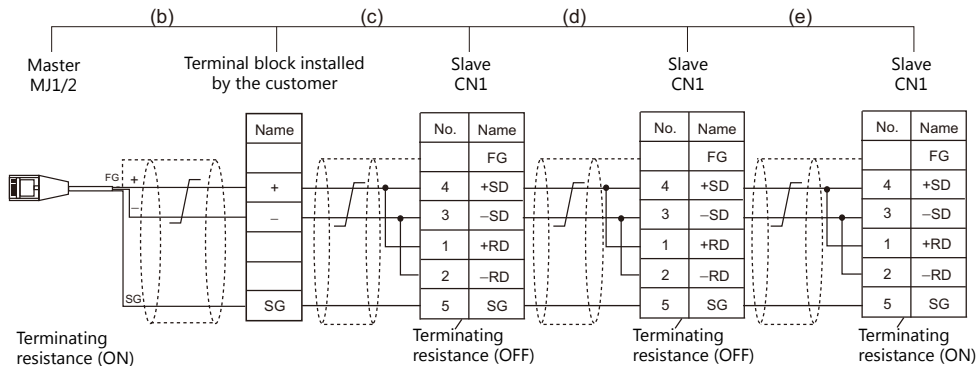

* As a measure against noise, connect the frame ground terminal of each V9 series at one side only. The frame ground of V6-MLT must be connected to the V9 series.

Connection Method 2

Connecting the CN1 of the master to the CN1s of the slaves

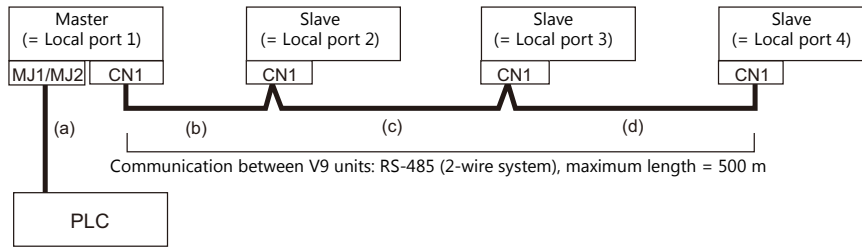

- (a) Connection between master and PLC
Choose the connection port between MJ1 and MJ2.
The communication settings and connection method are the same as those for 1 : 1 connection.
- (b), (c), (d) Connection between master and slave
Use the RS-485 (2-wire system) connection. It is convenient to install the optional terminal converter "TC-D9". Use twisted-pair cables of 0.3 mm sq or greater. The maximum length of the wiring is 500 m.

Wiring diagrams

- When a TC-D9 is used:
Set the slide switch of "TC-D9" to ON (2-wire system).

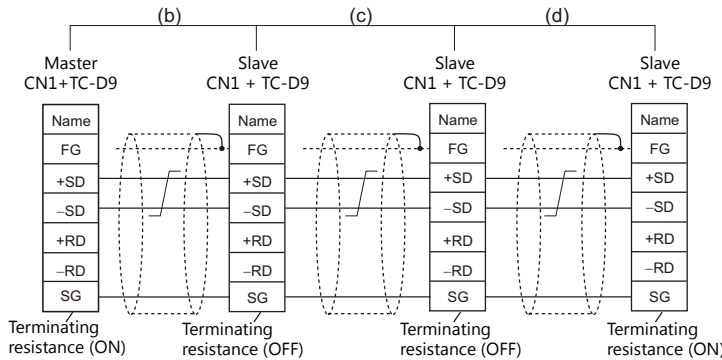

* As a measure against noise, connect the frame ground terminal of each V9 series at one side only.

- When no TC-D9 is used:
Install jumpers between +SD and +RD as well as -SD and -RD.

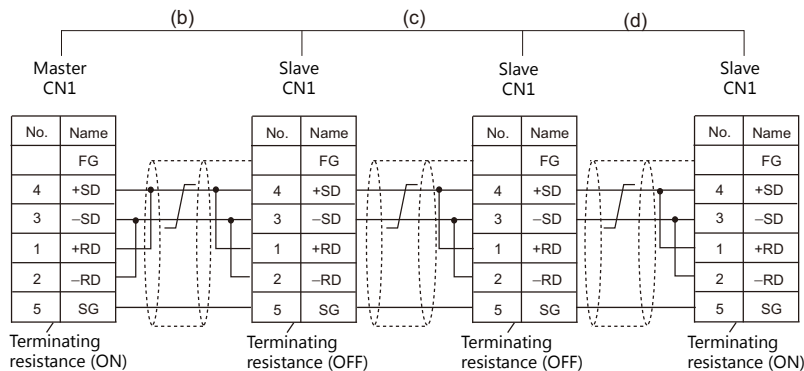

* As a measure against noise, connect the frame ground terminal of each V9 series at one side only.

Connection Method 4

Connecting the CN1 of the master to the MJ1/MJ2 of the slaves

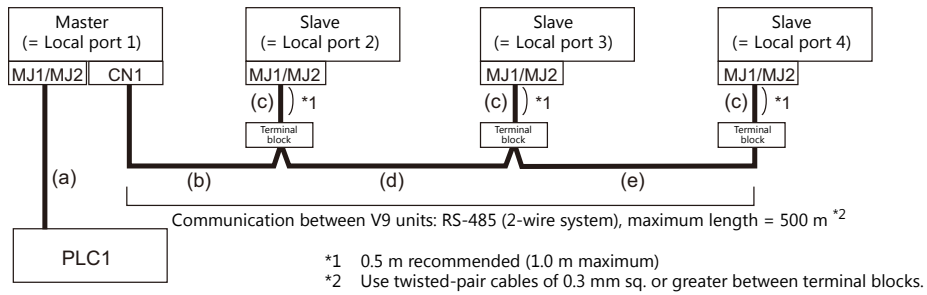

- (a) Connection between master and PLC
 Choose the connection port between MJ1 and MJ2.
 The communication settings and connection method are the same as those for 1 : 1 connection.
- (b), (d), (e) Connection between master and terminal block
 For the connecting port of the master, choose CN1. For the slave, choose between MJ1 and MJ2.
 Use the RS-485 (2-wire system) connection. Use twisted-pair cables of 0.3 mm sq or greater. The maximum length of the wiring is 500 m.
- (c) Connection between terminal block and slave
 The connecting port of the slave should be MJ1 or MJ2.
 Use the "V6-MLT" cable (3 m).

Wiring diagrams

- When a TC-D9 is used:
Set the slide switch of "TC-D9" to ON (2-wire system).

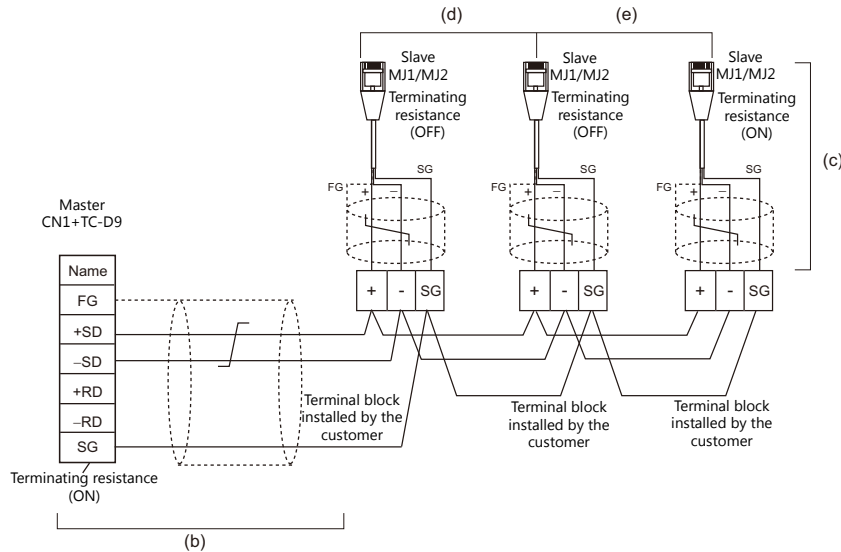

- When no TC-D9 is used:
Install jumpers between +SD and +RD as well as -SD and -RD.

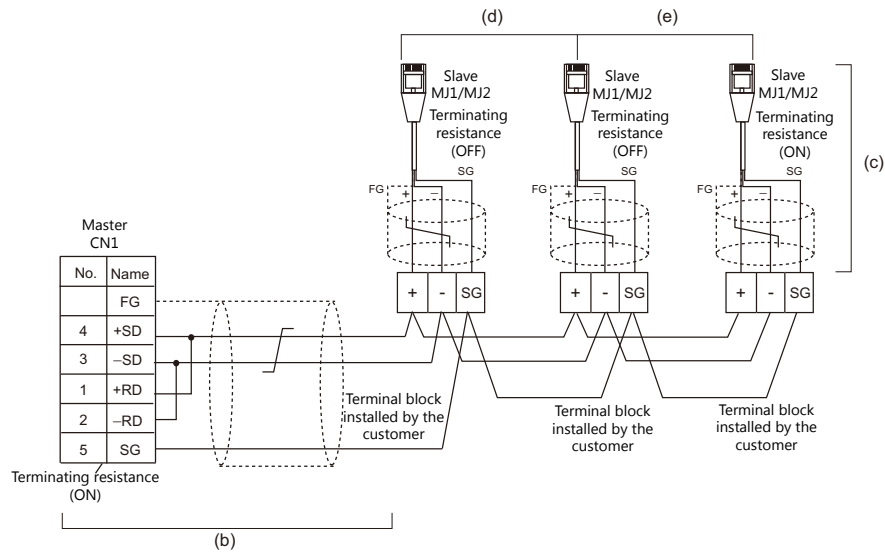

Terminating Resistance Setting

The terminating resistance should be set on the DIP switch.

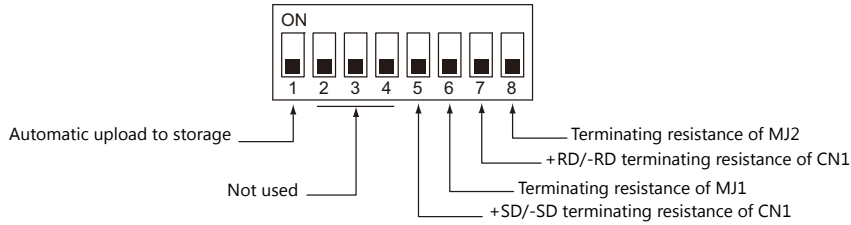

When the PLC is connected to the master via RS-232C:

There is no terminating resistance setting for communications between the master and the PLC. Set terminating resistances for connections between V9 units.

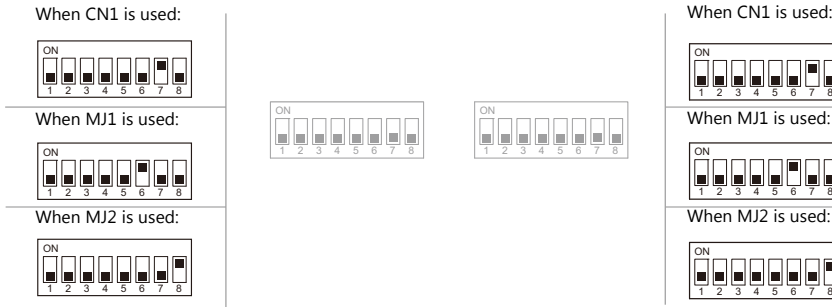
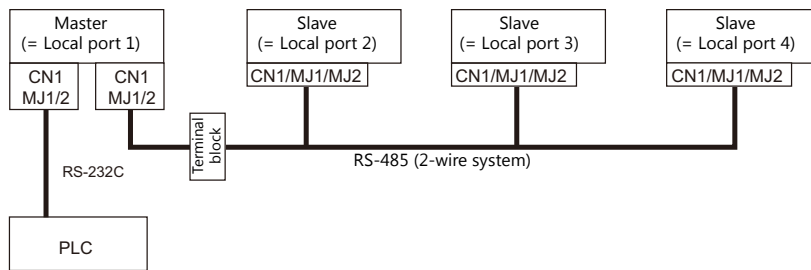

When the PLC is connected to the master via RS-422/485:

Make terminating resistance settings for communications between the master and PLC, and between V9 units.

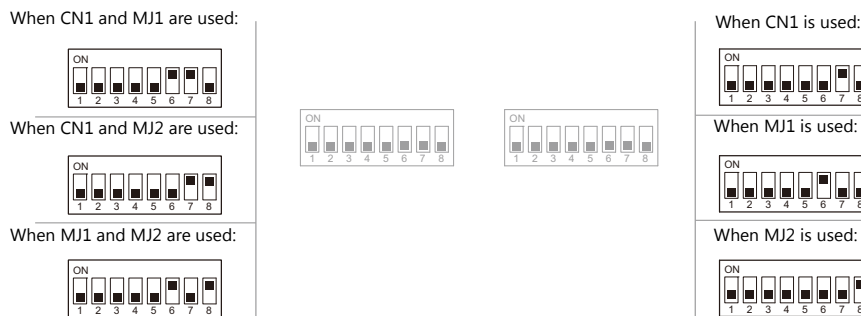
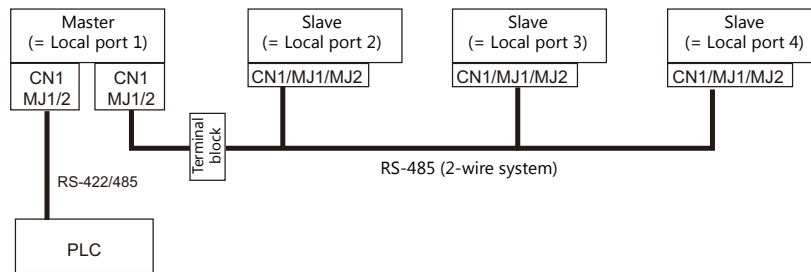

n: 1 Connection (Multi-link2 (Ethernet)) (Under Development)

Overview

- One PLC is connected to a maximum of 32 V9 units. The V8 series can be used together.
- Multi-link2 (Ethernet) enables you to establish an original network consisting of a master V9 of local port No. 1 and slave V9 units of local port Nos. 2 to 32. The master V9 communicates with the PLC directly, and the slave V9 units communicate with the PLC through the master.
 - Connection example

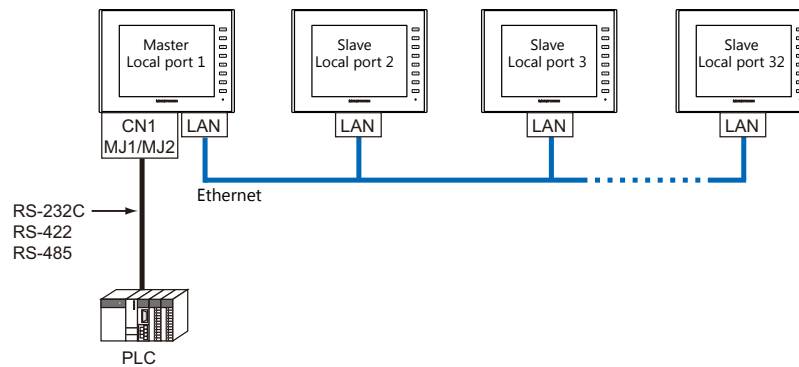

- You can make settings for multi-link2 (Ethernet) in [Communication Setting] for PLC1. Therefore, multi-link2 connection is not possible concurrently with a network connection that uses a "CUR-xx" communication interface unit.
- Multi-link2 (Ethernet) enables sharing of data stored in PLC1 device memory among the V9 units. However, sharing data in PLC2 - PLC8 is not possible.
- The V7 and V6 series cannot be used together.
- The communication speed between the master station and the PLC depends on the setting made on the PLC; however, communication among V9 units is performed via Ethernet, thus, high-speed communication is possible among them.
- For PLCs that support multi-link2 (Ethernet) connection, see Connection Compatibility List provided at the end of this manual.

The connection between the master and the PLC is the same as the one for 1 : 1 connection.
Ethernet connection is adopted to connect a master with slaves.
- If the master station becomes faulty (communication error), the master and slave stations do not work, and as a result, "Communication Error Time-Out" is displayed. If a slave station becomes faulty, "Data Loading..." is displayed due to a communication error only on the faulty station.
- The ladder transfer function is not available for a multi-link2 (Ethernet) connection.

V-SFT Ver. 6 Settings

Make settings on [Hardware Setting] → [PLC Properties]. The differences with respect to a 1 : 1 connection and the points where caution is required are explained here.

For details on other settings, refer to Hardware Settings in "1 : 1 Connection" (page 1-8).

PLC Properties

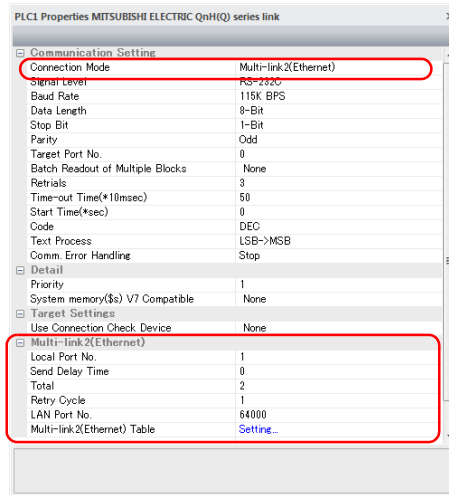

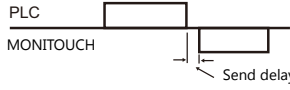
Item		Contents
Communication Setting	Connection Mode	Multi-link2 (Ethernet)
Multi-link2 (Ethernet)	Local Port No.	1: Master 2 to 32: Slave * Note that if the port number specified is the same as that already set for another V9 unit, the system will not operate correctly.
	Send Delay Time	Specify a delay time that elapses before V9 sends the next command after receiving data from the PLC. Normally use the default setting (0). 
	Total	2 to 32 Set the total number of V9 units connected in the multi-link2 (Ethernet) connection. The setting must be the same as other V9 series on the same communication line.
	Retry Cycle	Valid only when the local port is "1" (master). Set the number of cycles before the master sends an inquiry for restoration to a slave that has a communication problem (= system down). When a slave has a problem, it is temporarily removed from the communication targets, and the master sends an inquiry for restoration every number of cycles specified for [Retry Cycle]. This setting does not affect the communication speed if no problem is occurring on the slave; however, if there is any problem, it does affect the communication speed. When the setting value is small: Restoration will not take long. When the setting value is large: Restoration will take a longer time.
	LAN Port No.	Set a value in the range from 1024 to 65535 (excluding 8001 and 8020). Default: 64000 * Set the same port number for all master and slave stations.
	Multi-link2 (Ethernet) Table	Click [Setting] to display the [Multi-link2 (Ethernet) Table] window. For details on settings, refer to the next section.

Multi-link2 (Ethernet) table

- Master

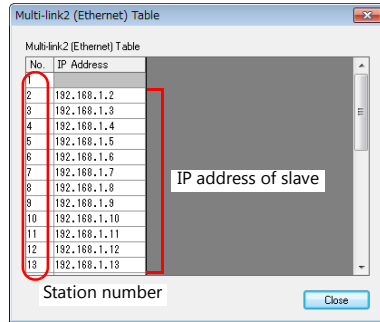

- Slave

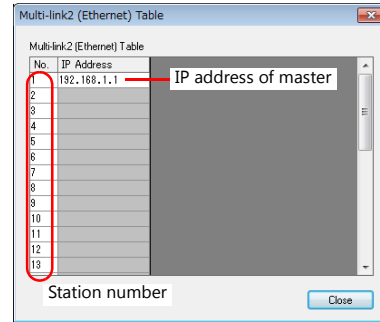

Item	Contents
Multi-link2 (Ethernet) Table	<ul style="list-style-type: none"> • For local port 1 (master) Set the IP addresses of all V9 units used as slave to respective local port numbers. • For local port 2 to 32 (slave) Set the IP address of the master V9 for No. 1.

Wiring

The connection between the master and the PLC is the same as the one for 1 : 1 connection. Refer to "Wiring" (page 1-10) in "1 : 1 Connection".

Use a LAN cable to connect a master with slaves.

n : n Connection (1: n Multi-link2 (Ethernet)) (Under Development)

Overview

- A maximum of 32 units of V9 series can be connected to a maximum of 31 units of PLCs.
- Multi-link2 (Ethernet) enables you to establish an original network consisting of a master V9 of local port No. 1 and slave V9 units of local port Nos. 2 to 32. The master V9 communicates with the PLC directly, and the slave V9 units communicate with the PLC through the master.

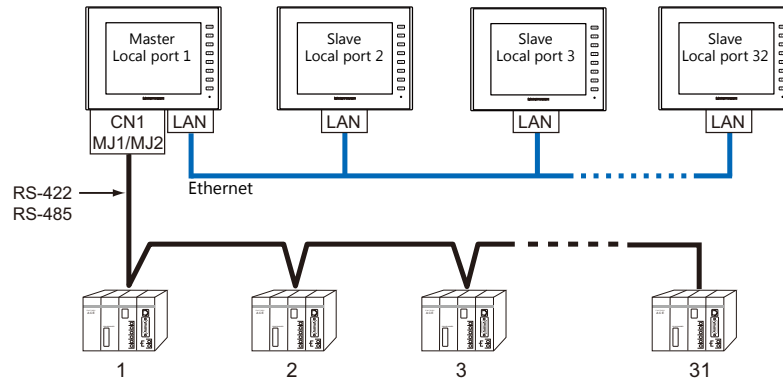

- You can make settings for 1 : n multi-link2 (Ethernet) in [Communication Setting] for PLC1. Therefore, multi-link2 connection is not possible concurrently with a network connection that uses a "CUR-xx" communication interface unit.
- 1 : n multi-link2 (Ethernet) enables sharing of data stored in PLC1 device memory among the V9 units. However, sharing data in PLC2 - PLC8 is not possible.
- The V7 and V6 series cannot be used together.
- The communication speed between the master station and the PLC depends on the setting made on the PLC; however, communication among V9 units is performed via Ethernet, thus, high-speed communication is possible among them.
- For PLCs that support 1 : n multi-link2 (Ethernet) connection, see Connection Compatibility List provided at the end of this manual.
The connection between the master and the PLC is the same as the one for 1 : n connection.
Ethernet connection is adopted to connect a master with slaves.
- If the master station becomes faulty (communication error), the master and slave stations do not work, and as a result, "Communication Error Time-Out" is displayed. If a slave station becomes faulty, "Data Loading..." is displayed due to a communication error only on the faulty station.
- The ladder transfer function is not available for a 1 : n multi-link2 (Ethernet) connection.

V-SFT Ver. 6 Settings

Make settings on [Hardware Setting] → [PLC Properties]. The differences with respect to a 1 : n connection and the points where care is required are explained here.

For details on other settings, refer to “Hardware Settings” (page 1-14) in “1 : n Connection (Multi-drop)”.

PLC Properties

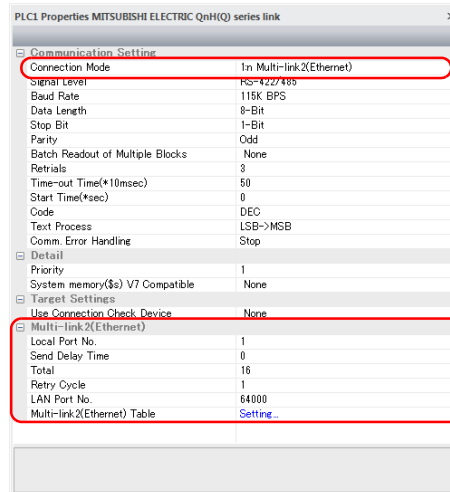

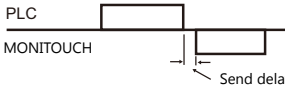
Item		Contents
Communication Setting	Connection Mode	1 : n Multi-link2 (Ethernet)
Multi-link2 (Ethernet)	Local Port No.	1: Master 2 to 32: Slave * Note that if the port number specified is the same as that already set for another V9 unit, the system will not operate correctly.
	Send Delay Time	Specify a delay time that elapses before V9 sends the next command after receiving data from the PLC. Normally use the default setting (0). 
	Total	2 to 32 Set the total number of V9 units connected in the multi-link2 (Ethernet) connection. The setting must be the same as other V9 series on the same communication line.
	Retry Cycle	Valid only when the local port is "1" (master). Set the number of cycles before the master sends an inquiry for restoration to a slave that has a communication problem (= system down). When a slave has a problem, it is temporarily removed from the communication targets, and the master sends an inquiry for restoration every number of cycles specified for [Retry Cycle]. This setting does not affect the communication speed if no problem is occurring on the slave; however, if there is any problem, it does affect the communication speed. When the setting value is small: Restoration will not take long. When the setting value is large: Restoration will take a longer time.
	LAN Port No.	Set a value in the range from 1024 to 65535 (excluding 8001 and 8020). Default: 64000 * Set the same port number for all master and slave stations.
	Multi-link2 (Ethernet) Table	Click [Setting] to display the [Multi-link2 (Ethernet) Table] window. For details on settings, refer to the next section.

Multi-link2 (Ethernet) table

- Master

No.	IP Address
1	
2	192.168.1.2
3	192.168.1.3
4	192.168.1.4
5	192.168.1.5
6	192.168.1.6
7	192.168.1.7
8	192.168.1.8
9	192.168.1.9
10	192.168.1.10
11	192.168.1.11
12	192.168.1.12
13	192.168.1.13

Station number

- Slave

No.	IP Address
1	192.168.1.1
2	
3	
4	
5	
6	
7	
8	
9	
10	
11	
12	
13	

Station number

Item	Contents
Multi-link2 (Ethernet) Table	<ul style="list-style-type: none"> • For local port 1 (master) Set the IP addresses of all V9 units used as slave to respective local port numbers. • For local port 2 to 32 (slave) Set the IP address of the master V9 for No. 1.

Wiring

The connection between the master and the PLC is the same as the one for 1 : n connection. Refer to "Wiring" (page 1-15) in "1 : n Connection (Multi-drop)".

Use a LAN cable to connect a master with slaves.

n : 1 Connection (Multi-link) (Under Development)

Overview

- One PLC is connected to a maximum of 31 V9 units. The V8, V7, and V6 series can be used together.
 - Connection example 1:

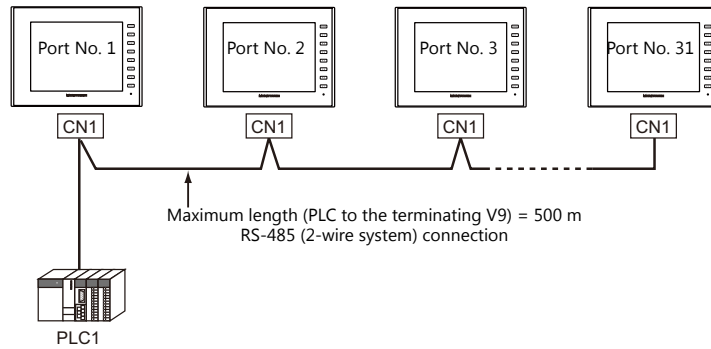

- Connection example 2:

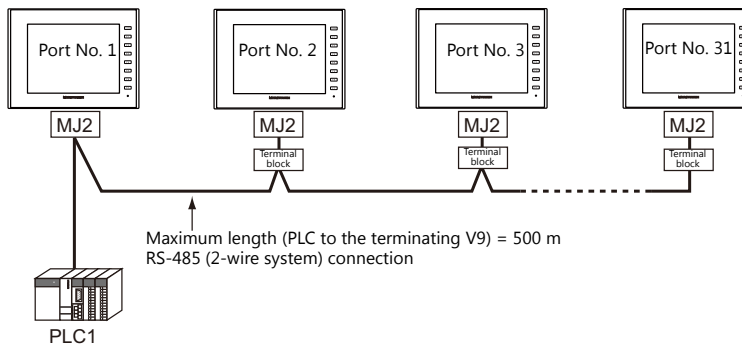

- You can make settings for multi-link at the PLC1. For the V9 and V8 series, a physical port is selectable from CN1, MJ1, and MJ2. For the V7 or V6 series, however, use CN1 only.
- Only a PLC [Signal Level: RS422/RS485] and with a port number set. RS-485 (2-wire system) connection is adopted to connect a V-series unit and a PLC. For available models, see Connection Compatibility List provided at the end of this manual.
- Use twisted-pair cables of 0.3 mm sq. or greater between terminal blocks.
- The ladder transfer function is not available for a multi-link connection.

V-SFT Ver. 6 Settings

Make settings on [Hardware Setting] → [PLC Properties]. The differences with respect to a 1 : 1 connection and the points where care is required are explained here.

For details on other settings, refer to Hardware Settings in "1 : 1 Connection" (page 1-8).

PLC Properties

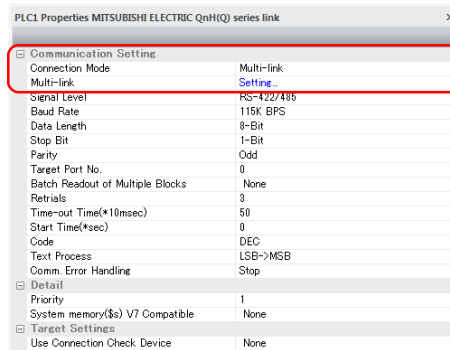

Item		Contents
Communication Setting	Connection Mode	Multi-link
	Multi-link	Display the [Multi-link] dialog by pressing the [Setting] button, then make the necessary settings in this dialog. For more information on settings, see "Multi-link" (page 1-32).

Multi-link

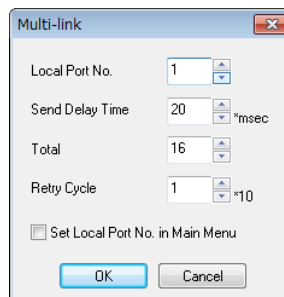

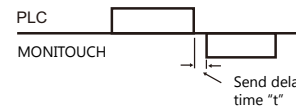
Item	Contents
Local Port No.	1 to 32 Specify a port number of the V9. * Note that if the port number specified is the same as that already set for another V9 unit, the system will not operate correctly.
Send Delay Time ^{*1}	0 to 255 msec (Default setting: 20 msec) Specify a delay time that elapses before V9 sends the next command after receiving data from the PLC. 
Total ^{*1}	2 to 32 Set the maximum number of V series units to be connected in multi-link connection. ^{*2}
Retry Cycle ^{*1}	1 to 100 (× 10) When the V9 series has a problem, it is temporarily removed from the communication targets, and the master sends an inquiry for restoration every number of cycles specified for [Retry Cycle]. This setting does not affect the communication speed if no problem is occurring; however, if there is any problem, it does affect the communication speed. When the setting value is small: Restoration will not take long. When the setting value is large: Restoration will take a longer time.
Set Local Port No. in Main Menu	<ul style="list-style-type: none"> Unchecked Set the local port number on the screen program. Checked Set the local port number on MONITOUCH (see page 1-33).

^{*1} For [Send Delay Time], [Total] and [Retry Cycle], the same values must be set on all the V9 series that are connected in the same communication line.

^{*2} When connecting three units with the local port numbers 1, 2 and 10, specify "10" for [Total].

MONITOUCH Setting

Local port setting (Local mode)

When [Set Local Port No. in Main Menu] is checked in the [Multi-link] window, the local port number must be set in Local mode on the V9 series.

1. Transfer the screen program.
2. Switch to Local mode on MONITOUCH.
3. Press the [Communication Setting] switch and display the Communication Setting screen.
4. Set the [Local Port No] on the [Individual Parameter] tab window.
5. Press the [Apply] switch.

Wiring

When Connected at CN1

This shows the situation when a multi-link connection is made at CN1. It is convenient to use the Hakko Electronics' optional terminal converter "TC-D9".

- When a TC-D9 is used:
Set the slide switch of "TC-D9" to ON (2-wire system).

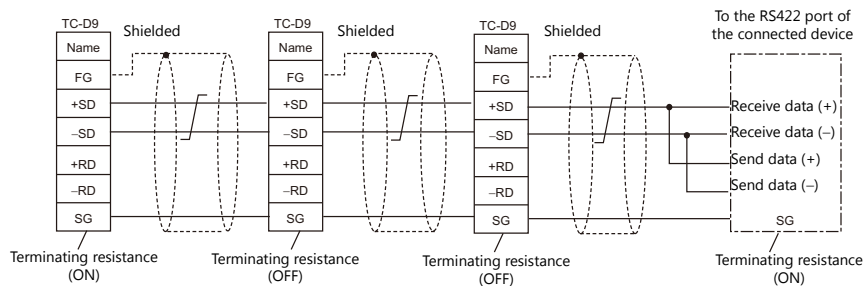

* Use shielded twist-pair cables.

* Jumpers may not be necessary, depending on the connected device.

- When no TC-D9 is used:
Install jumpers between +SD and +RD as well as -SD and -RD.

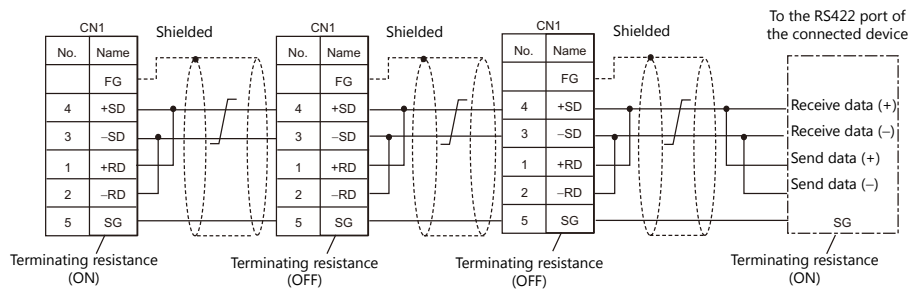

* Use shielded twist-pair cables.

* Jumpers may not be necessary, depending on the connected device.

When connecting to Mitsubishi Electric's QnA CPU:

Use the GD port of Hakko Electronics' optional dual port interface V-MDD for the PLC CPU port.

- When a TC-D9 is used:
Set the slide switch of "TC-D9" to ON (2-wire system).

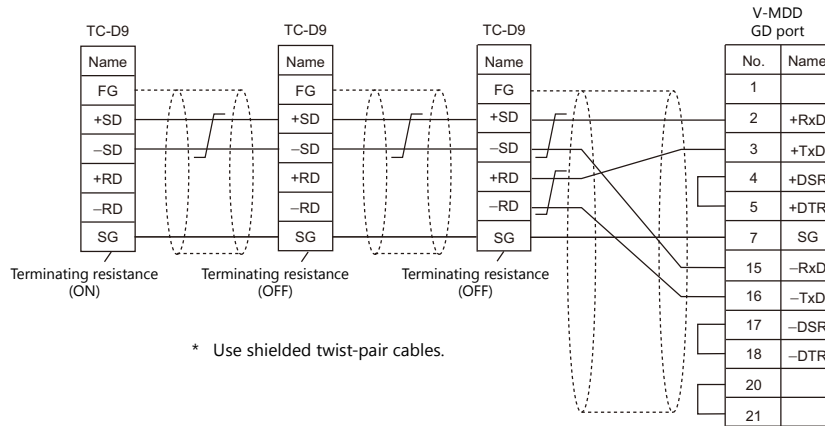

- When no TC-D9 is used:
Install jumpers between +SD and +RD as well as -SD and -RD.

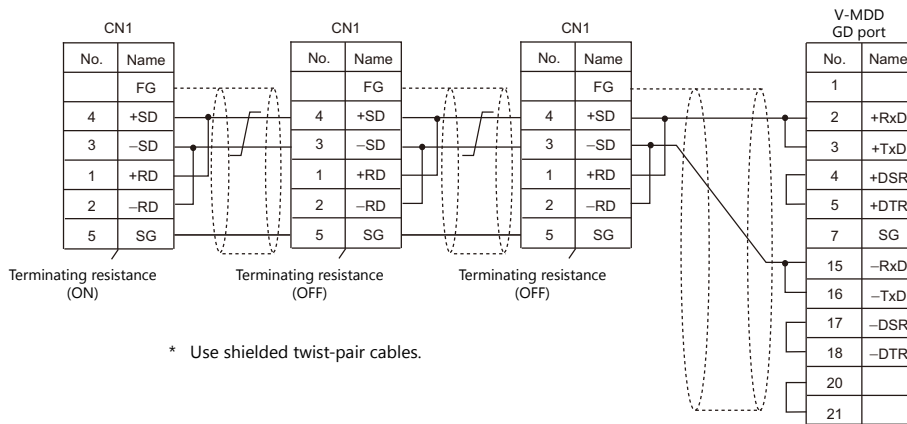

When Connected at MJ1/MJ2:

This shows the situation when a multi-link connection is made at MJ1 or MJ2.

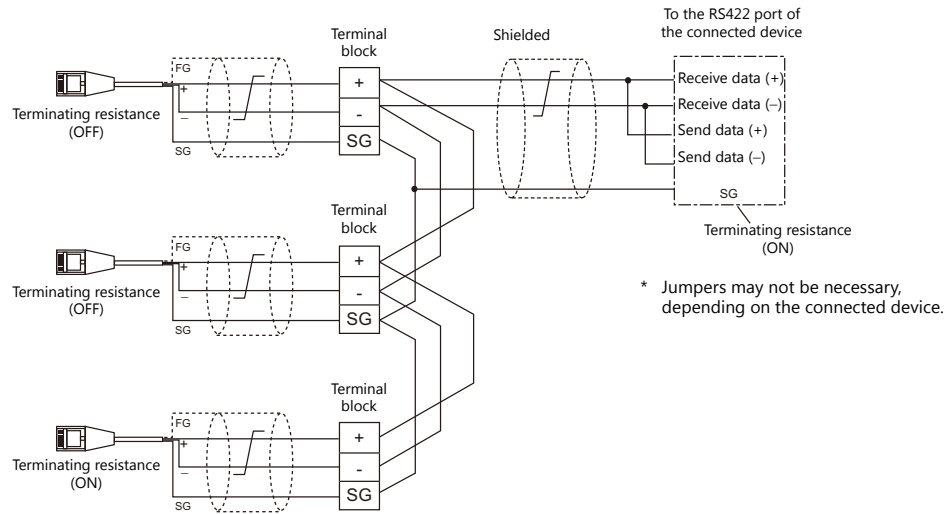

When connecting to Mitsubishi Electric's QnA CPU:

Use the GD port of Hakko Electronics' optional dual port interface V-MDD for the PLC CPU port.

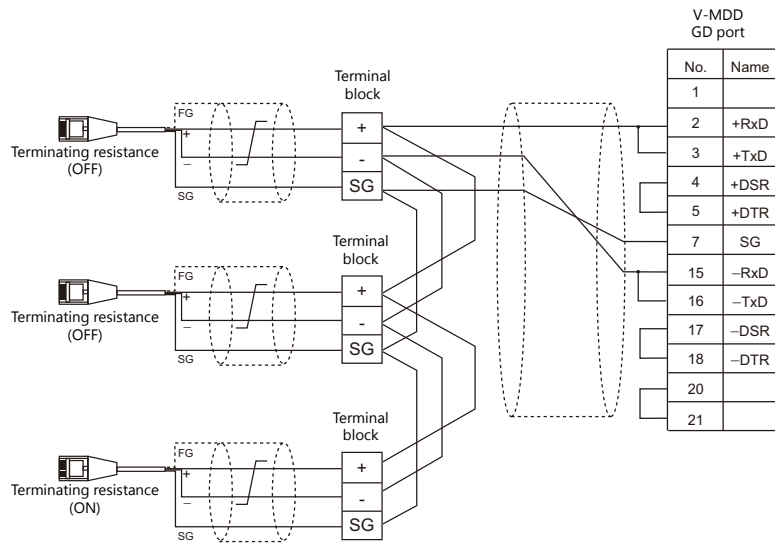

1.3.2 Ethernet Communication

Overview

- Because eight communication ports can be opened, the V9 series is allowed to communicate with eight models of PLCs at the same time.

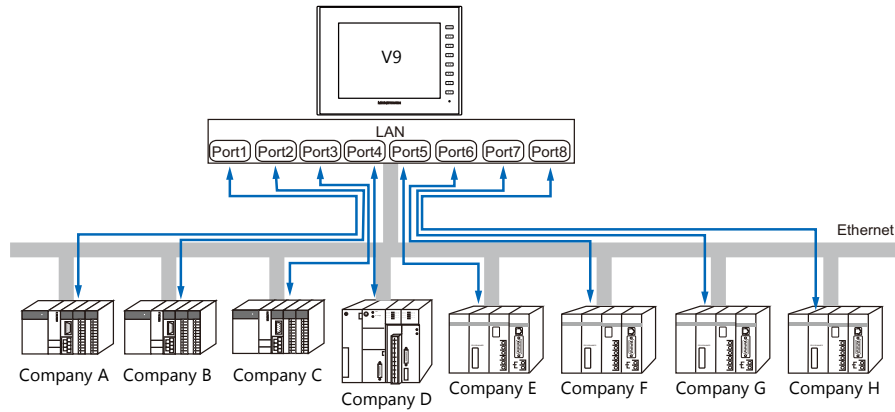

- When there are two or more PLCs of the same model, the V9 series is allowed to carry out 1 : n communication via one single port.

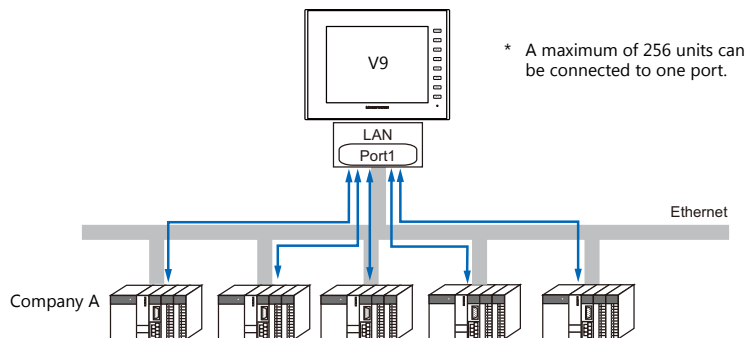

- If multiple V9 units are connected to one single PLC, the maximum permissible number of these units depends on the PLC specifications. Refer to the PLC manual issued by the manufacturer.

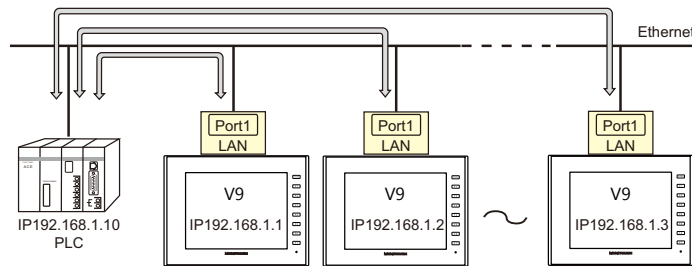

- You can make settings for Ethernet communication in [Communication Setting] for the logical ports PLC1 - PLC8.

V-SFT Ver. 6 Settings

Hardware Settings

Selecting a device to be connected

Select the device for connection from [System Setting] → [Hardware Setting].

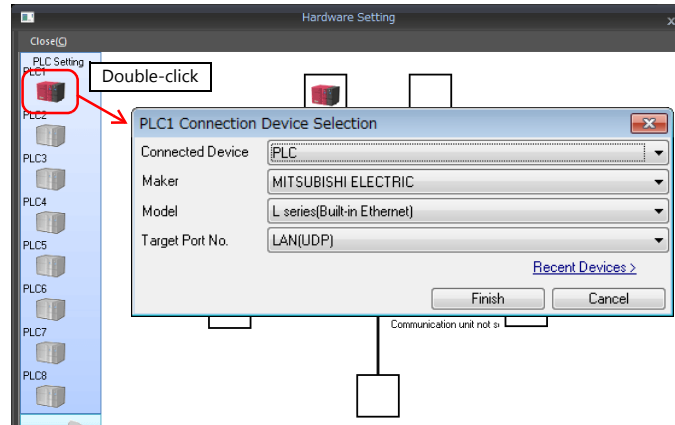

PLC properties

Configure the [PLC Properties].

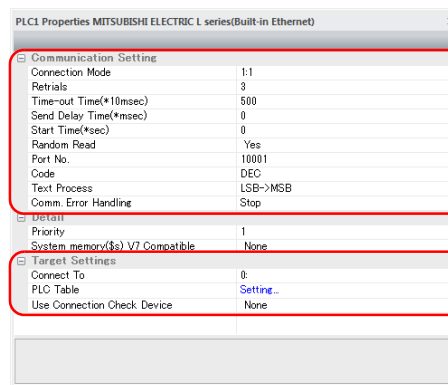

Item		Contents
Communication Setting	Connection Mode	1:1/1:n Set the number of PLCs that are to be communicated with.
	Port No.	Set the port number of the V9 series to be used for communications with the PLCs.
	KeepAlive (Under development)	<p>This setting is used when using the "KeepAlive" function. The "KeepAlive" function is used for periodically checking the connection with devices on the network. This function enables a prompt detection of a communication error, thus, significantly shortens the time to wait until a "disconnect" process takes place after an occurrence of the time-out error.</p> <p>* When using this function, select [Disconnect] for [Comm. Error Handling].</p> <ul style="list-style-type: none"> [Use KeepAlive] <ul style="list-style-type: none"> Select [Yes] when using the "KeepAlive" function. The following settings will take effect. <ul style="list-style-type: none"> - [Retrials] <ul style="list-style-type: none"> Specify the number of retries. If a timeout persists even after as many retries as specified, an error handling routine will take place. 0 to 255 Default: 0 - [Time-out Time] <ul style="list-style-type: none"> Specify a period of time allowed for V9 to monitor a response from its connected device. If no response is given within the specified time, retry will be made. 1 to 999 (× 10 msec) Default: 30 (× 10 msec) - [Checking Cycle] <ul style="list-style-type: none"> Set the cycle time of "KeepAlive" communication. 1 to 999 (× 10 msec) Default: 10 (× 10 msec)

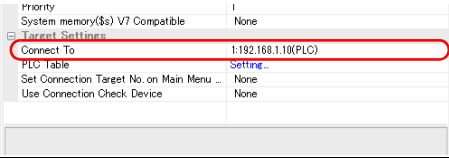
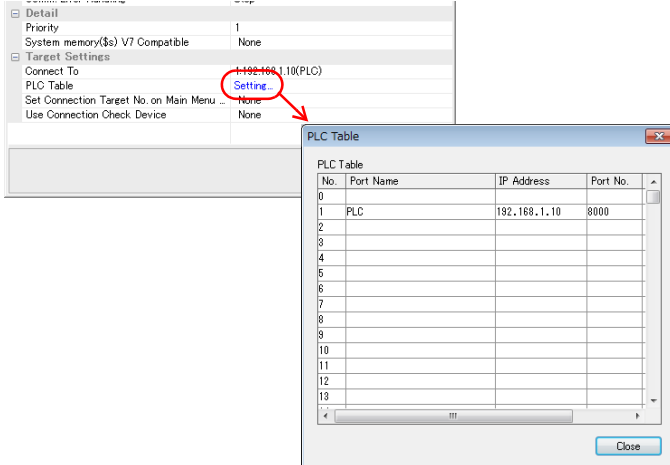
Item		Contents
Target Settings	Connect To	<p>These settings are valid when [1 : 1] is selected for [Connection Mode]. Select the IP address of the PLC registered in the PLC table. 1 : 1 communications are executed with the PLC selected here.</p> 
	PLC Table	<p>Click [Setting] to display the [PLC Table] window. Set the IP address, port number and KeepAlive function (under development) of the PLC.</p> 

* For settings other than the above, see "1.4 Hardware Settings" (page 1-43).

IP Address Setting of the V9 Series

An IP address must be set for the V9 to connect to devices via Ethernet. Set the IP address either on the V9 unit or for the screen program using the V-SFT editor.

Setting Using the V-SFT Editor

Set the IP address at [System Setting] → [Hardware Setting] → [Local Port IP Address].

Local port IP address setting

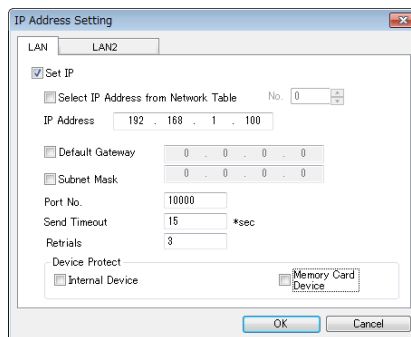

Item	Contents
Select IP Address from Network Table	<p>This is valid when the IP address of the V9 has been registered in the network table. Select a network table number from 0 to 255 to set the IP address.</p> <p>* For more information on the network table, refer to "Network table" (page 1-50).</p>
IP Address *1	Set the IP address for the V9.
Default Gateway *1	Set the default gateway.
Subnet Mask *1	<p>Set the subnet mask. When this box is not checked, the subnet mask is automatically assigned based on the byte at the extreme left of the IP address.</p> <p>Example: When IP address is "172.16.200.185", "255.255.0.0" is set. When IP address is "192.168.1.185", "255.255.255.0" is set.</p>
Port No. *1	Set a port number from 1024 to 65535. (Excluding 8001 and 8020)

Item	Contents
Send Timeout	Specify the timeout time to send the EREAD/EWRITE/SEND/MES command.
Retrials	0 to 255 Set the number of retrials to be performed when a time-out occurs.
Device Protect Internal Device Memory Card Device	Check either check box to write-protect the device memory from computers or other stations.

*1 For more information on each setting item, see "Basics of ethernet settings" (page 1-51).

Settings in Local Mode on the V9 Unit

Set the IP address in Local mode on the V9 unit.

If IP address setting has been performed on the V-SFT editor, this setting will be taken as the valid one.

1. Press the [SYSTEM] switch on MONITOUCH to display the system menu.
2. Press the [Local] switch. The display switches to Local mode.
3. Press the [LAN Setting] switch and display the LAN Setting screen.

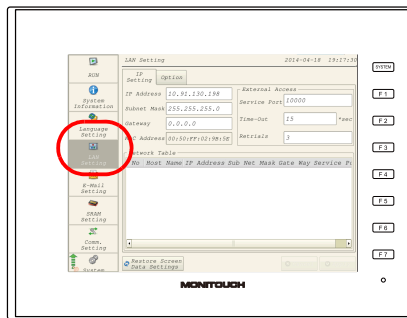

4. Set each item.



5. Press the [Apply] switch to determine the setting.

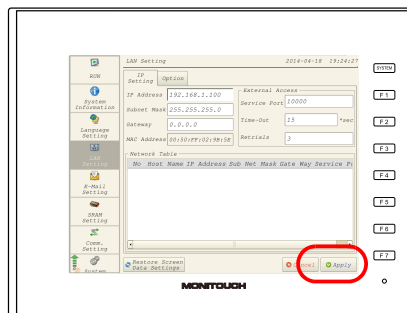

* Press the [Return to Screen Data Setting] to return to the settings made on the V-SFT editor.

Connection Example

With hub

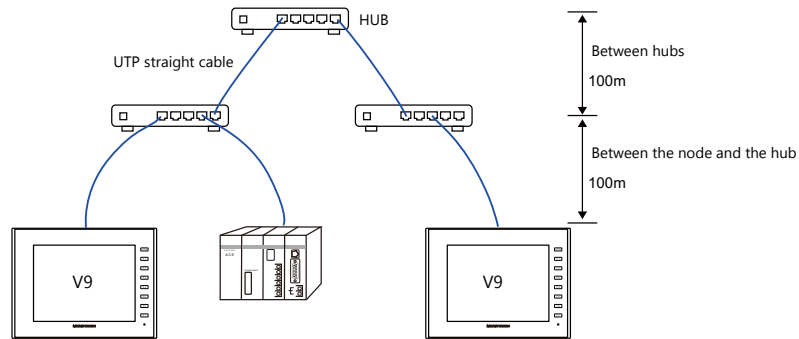

Without hub

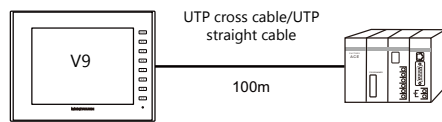

Wiring



- Use a commercially available cable. Using a self-made cable may cause an error in network connection.
- If the use of a cross cable cannot stabilize communication, use a hub.

- Straight cable

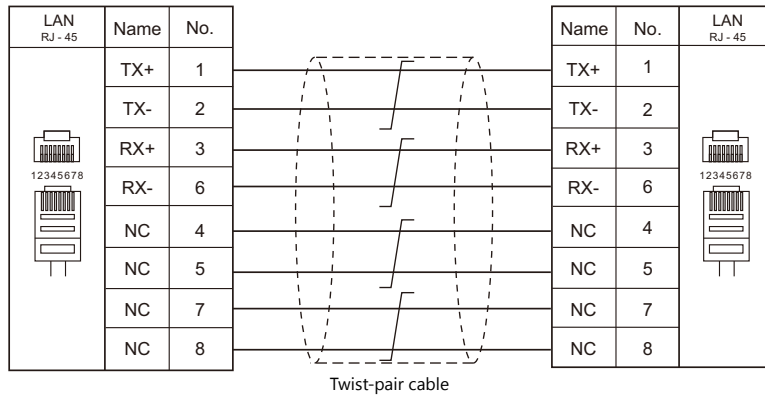

- Cross cable

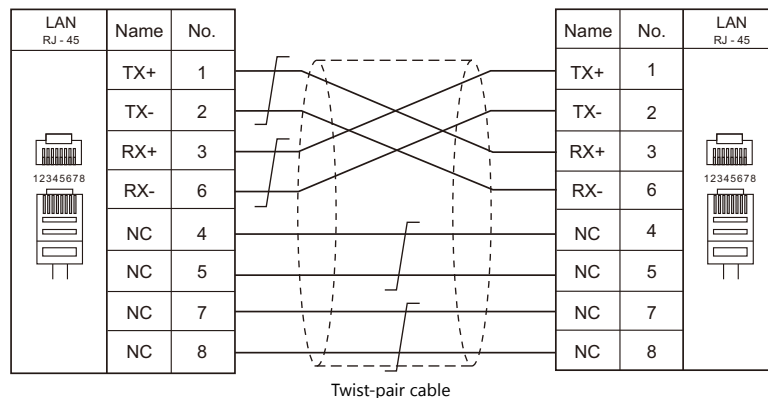

1.3.3 Network Communication (Under Development)

Overview

- The optional communication interface unit "CUR-xx" is required to enable a network communication listed below.

Communication Interface Unit	Network	Available Models		Remarks
CUR-00	OPCN-1	Mitsubishi Electric OMRON Fuji Electric	A series (OPCN-1) SYSMAC C (OPCN-1) MICREX-SX (OPCN-1)	Under development
CUR-01	T-Link	Fuji Electric Fuji Electric	MICREX-F (T-LINK) MICREX SX (T-LINK)	Under development
CUR-02	CC-LINK Ver.2.0	Mitsubishi Electric Mitsubishi Electric Mitsubishi Electric	A series (CC-LINK) QnA series (CC-LINK) QnH (Q) series (CC-LINK)	Under development
CUR-03	Ethernet *1	Various PLCs	Ethernet UDP/IP communication	Under development
CUR-04	PROFIBUS-DP	Siemens Universal PROFIBUS-DP	S7 PROFIBUS-DP	Under development
CUR-06	SX BUS	Fuji Electric	MICREX-SX (SX BUS)	Under development
CUR-07	DeviceNet		-	Under development
CUR-08	FL-Net	Universal FL-Net		Under development

*1 In addition to UDP/IP communication with a PLC, screen program transfer, the MES interface function, and TELLUS & V-Server connection can be enabled by connecting a PC. Use the built-in LAN port for TCP/IP communication.

- You can make settings for network communication in [Communication Setting] for the logical port PLC1. Thus, devices available with only PLC1, as those used for multi-link or multi-link2, cannot be connected concurrently for network communication.

V-SFT Ver. 6 Settings

For more information, refer to the communication unit specifications provided for each network.

Wiring

For more information, refer to the communication unit specifications provided for each network.

1.3.4 Slave Communication

Connecting via V-Link, Modbus RTU, or Modbus TCP/IP is applicable to slave communication using the V9. V-Link and Modbus RTU are used for serial communication, and Modbus TCP/IP is used for Ethernet (TCP/IP) communication.

V-Link

- "V-Link" is the network where the PC reads from and writes to the internal device memory of the V9 series, memory card device memory, or PLC1 to 8 device memory using a dedicated protocol.

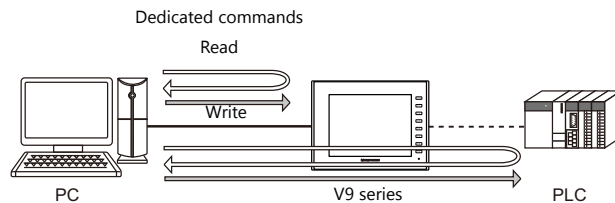

- You can make settings for V-Link communication in [Communication Setting] for the logical ports PLC2 - PLC8. A communication port is selectable from CN1, MJ1, and MJ2.
- For more information, refer to "V-Link" in book 3 of the V9 Series Connection Manual.

MODBUS RTU

- The V9 series is connected to a Modbus RTU master via serial connection.
- The device memory table for Modbus slave communication is prepared for the V9. The master is allowed to gain access to the device memory table and read/write the PLC data.
- For more information, refer to the Modbus Slave Communication Specifications manual separately provided.

MODBUS TCP/IP

- The V9 is connected to a Modbus TCP/IP master via Ethernet communication.
- The device memory table for Modbus slave communication is prepared for the V9. The master is allowed to gain access to the device memory table and read/write the PLC data.
- For more information, refer to the Modbus Slave Communication Specifications manual separately provided.

1.3.5 Other Connections

For connection to a serial printer that is not in 8-way communication, serial ports of MJ1 and MJ2 are used.

1.4 Hardware Settings

Select and set the devices to connect to the V9 series on the Hardware Setting screen.

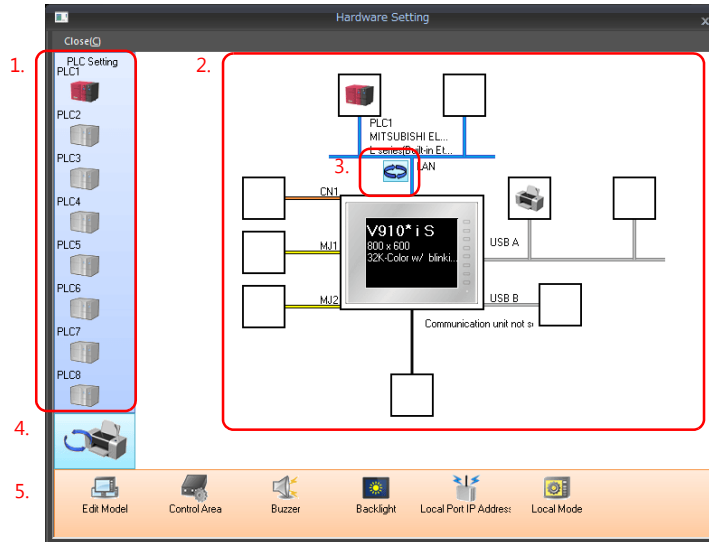

Item	Contents
1.	PLC Setting Set the devices (PLC, temperature controller, servo, inverter, barcode reader etc.) to connect to PLC1 to PLC8.
2.	Connection Diagram The devices which are set for connection are displayed. Devices as well as communication settings can be changed.
3.	Built-in LAN / Ethernet unit switch Select the Ethernet connection port on the V9 series from the internal LAN communication unit. The icon changes each time it is clicked.
4.	PLC Setting / Other Setting switch Switch between PLC settings and other settings. The icon changes each time it is clicked.
5.	MONITOUCH Settings Make MONITOUCH settings on the V9 series.

1.4.1 PLC Settings

To enable communication with a PLC, a temperature controller, an inverter, etc., the following settings are required to be set on the editor. You can see the contents of these settings in the V9 Local mode.
For information on Local mode, refer to the V9 Series Troubleshooting/Maintenance Manual.

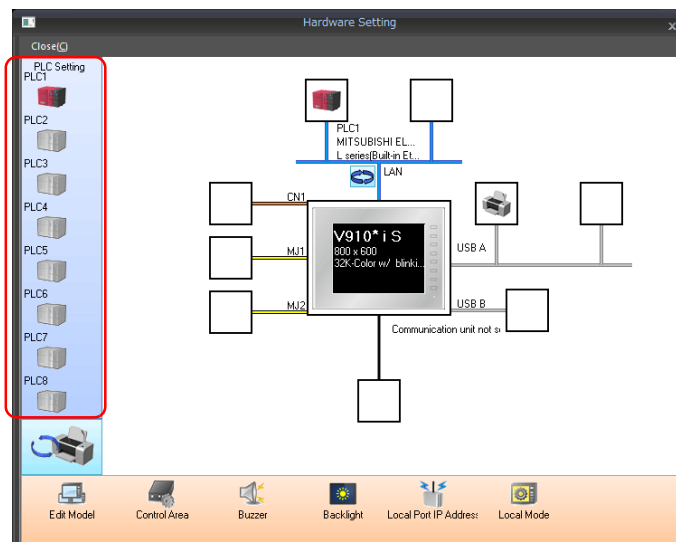

Selecting a Device to be Connected

Double-click on a PLC icon in the [Hardware Setting] window to display the window shown below.

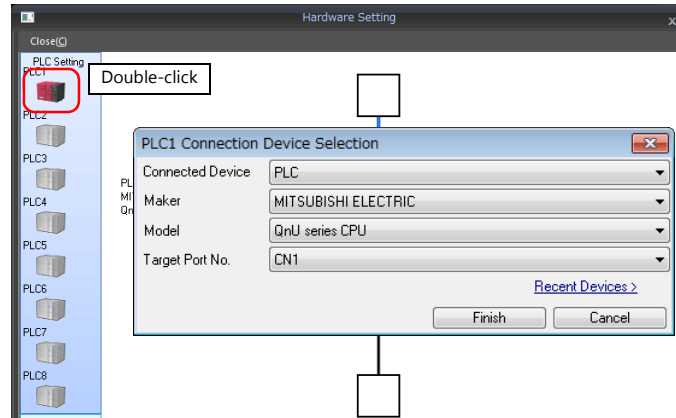

Item	Contents
Connected Device	Select the device to connect.
Maker	Select the maker of the device.
Model	Select the model of the device to connect. Refer to the respective chapter of each maker and select the appropriate model.
Target Port No.	Select the port to which the device connects to on the V9 series.

PLC Properties

Click on the PLC icon in [Hardware Setting] to display the window shown below.

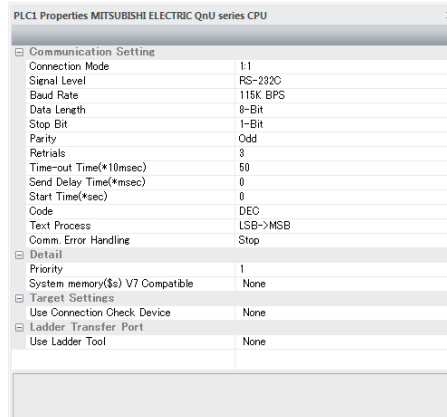

Item	Contents	
Communication Setting	Connection Mode	Select a connection mode. 1 : 1 / 1 : n / Multi-link / Multi-link2 (Ethernet) / 1 : n Multi-link2 (Ethernet) Available options vary, depending on which device is connected. For details, see Connection Compatibility List provided at the end of this manual.
	Signal Level ^{*1}	Select a signal level. RS-232C/RS-422/485
	Baud Rate ^{*1}	Select a baud rate. 4800/9600/19200/38400/57600/76800/115K/187.5K [*] bps [*] Available only when connecting via Siemens S7-200PPI or S7-300/400MPI and CN1.
	Data Length ^{*1}	Select a data length. 7 / 8 bits
	Stop Bit ^{*1}	Select a stop bit. 1 / 2 bits
	Parity ^{*1}	Select an option for parity bit. None / Odd / Even
	Target Port No. ^{*1}	Specify a port number of the connected device. 0 to 31 (Modbus RTU: 1 to 255)

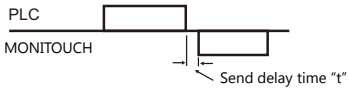
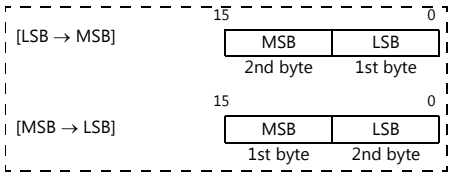
Item		Contents
Communication Setting	Transmission Mode ^{*1}	Select a transmission mode for the connected device. This setting is required if a device of Mitsubishi, Omron, Hitachi Industrial Equipment Systems, Yokogawa, JTEKT, or Yaskawa is in use.
	Retrials	Specify the number of retrials to be allowed in the event of a timeout during communication. If a timeout persists even after as many retrials as specified, an error handling routine will take place. 1 to 255
	Time-out Time	Specify a period of time allowed for V9 to monitor a response from its connected device. If no response is given within the specified time, retrial will be made. 0 to 999 (×10 msec)
	Send Delay Time	Specify a delay time that elapses before V9 sends the next command after receiving a response from its connected device. Normally use the default setting. 0 to 255 (×1 msec) 
	Start Time	Specify a delay time that elapses before V9 starts to send commands upon power-up. If V9 and its connected device are turned on at the same time and the device is slower to start up, set [Start Time]. 0 to 255 (×1 sec)
	Code	Select a code for the connected device. The selected option is reflected through the data displayed on graphs or trending sampling parts. DEC/BCD
	Text Process	Specify a byte order in text data. This setting is valid for macro commands that handle text. LSB → MSB/MSB → LSB 
	Comm. Error Handling	Select an action to be taken in the event of a communication error. <ul style="list-style-type: none"> • [Stop] Communication will be stopped entirely and the communication error screen will be displayed. The [RETRY] switch is available for attempting reestablishment of communication. • [Continue] The communication error message will be displayed at the center of the screen. The same communication will continue until restoration, and screen operation is not allowed then. When communication has been returned to a normal state, the message disappears and screen operation is allowed. • [Disconnect] No error message will appear and communication will proceed to the next one. However, communication with the device, in which a timeout was detected, will be disconnected. When a timeout is detected, ⚠ will be displayed for the part that is monitoring the address of the timeout device. <p>* The communication status is displayed on the status bar. For information, refer to the V9 Series Troubleshooting/Maintenance Manual.</p>
	Recovery Condition	Use Recovery Time
Recovery Time		Return Time 1 to 255 (×10 sec) When the specified time has elapsed, V9 checks the recovery of the device which discontinued communicating.
Auto-restoration upon screen switch-over		When the screen is switched, V9 checks the recovery of the device which discontinued communicating.

Item		Contents
Detail	Priority	[1] (higher priority) - [8] (lower priority) Specify the priority taken during 8-way communication. If interrupts from two or more devices occur at the same time, communication with these devices will take place in order of priority.
	System device (\$) V7 Compatible (PLC1)	This is set to [Yes] if the V7-series screen program (including temperature control network/PLC2Way settings) has been converted to data for the V9 series. System information relevant to 8-way communication will be stored in device memory addresses \$P1 and \$s. * For more information, see "1.5.1 \$Pn (For 8-way Communication)" (page 1-55).
	System device (\$) V7 Compatible (PLC2)	This is set to [Yes] if the V7-series screen program (including temperature control network/PLC2Way settings) has been converted to data for the V9 series. <ul style="list-style-type: none"> [None] \$P2:493/494/495 is used as the transfer table control device memory. [Yes] \$s762/763/764 is used as the transfer table control device memory. * For more information, see "1.5.1 \$Pn (For 8-way Communication)" (page 1-55).
	Device Memory Map Control Device	Specify the device memory for controlling device memory maps of PLC1 - PLC8. The device memory specified here is the same as [Control Device] in [Device Memory Map Setting] ([System Setting] → [Device Memory Map] → [Device Memory Map Edit] window → [Device Memory Map Setting]). * For more information, refer to the V9 Series Reference Manual.
Target Settings	Connect To PLC Table	Set this for Ethernet communication. For more information, see "1.3.2 Ethernet Communication" (page 1-36).
	Use Connection Check Device	Select [Yes] for connection confirmation using a desired device memory address at the start of communication.
	Connection Check Device	Specify a desired device memory address used for connection confirmation.
Ladder Transfer Port	Use Ladder Tool	This setting is used when using the ladder transfer tool. * For more information, refer to the V9 Series Reference Manual.
	Connection target	
	Ladder Communication in Local Mode	

*1 Be sure to match the settings to those made on the connected device.

1.4.2 MONITOUCH Settings

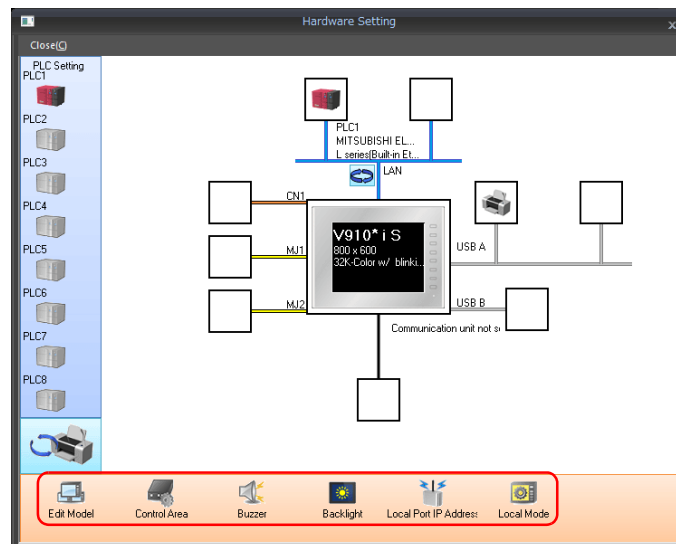

Select Edit Model

Set the model of the V series to edit.
For more information, refer to the V9 Series Reference Manual.

Control Area

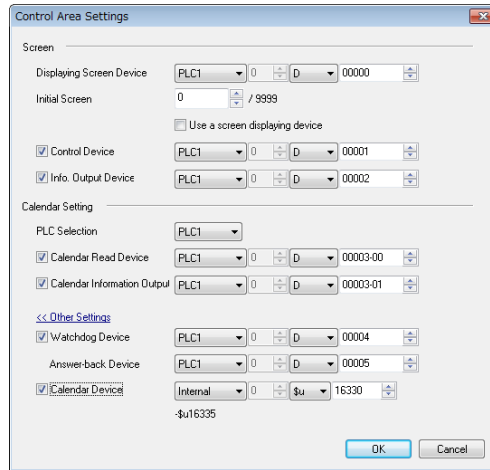

Item		Contents
Screen	Displaying Screen Device	This device memory is used for switching the screen by an external command. When a screen number is specified in a device memory, the screen is displayed. When the screen is switched by an internal switch, the currently displayed screen number is stored in this device memory.
	Initial Screen	Set the number of the screen to be displayed at start up. * When recovering from a communication error, the screen number which was set for the screen displaying device memory is displayed.
	Use a screen displaying device	When this is checked, the screen number which was set for the screen displaying device memory is displayed as the initial screen.
	Control Device	For more information, refer to the V9 Series Reference Manual.
	Info. Output Device	
Calendar Setting	PLC Selection	This setting is valid when the V9 s built-in clock is not used. The setting allows the calendar data to be read from device memory via the selected port at PLC1 - PLC8.
	Calendar Read Device	This setting is valid when the V9 s built-in clock is not used. This bit should be used differently depending on whether the connected PLC is equipped with the calendar function. <ul style="list-style-type: none"> When MONITOUCH is connected to a PLC with calendar function: When calendar data in the PLC is updated, it can forcibly be read by setting this bit (at the leading edge of [0 → 1]). In addition to calendar data update using this bit, calendar data in the PLC is automatically read and updated when: <ul style="list-style-type: none"> The power is turned on. STOP → RUN The date changes (AM 00:00:00). When MONITOUCH is connected to a PLC without calendar function: A virtual calendar area can be provided by setting [Calendar Device] in [Other Settings]. Setting this bit (ON) will set the data stored in the calendar device memory as calendar data for MONITOUCH.
	Calendar Information Output Device	The status of the calendar read device memory is stored.
Other Settings	Watchdog Device	When data is saved in this area, the same data is written to [Answer-back Device] after the screen has been displayed. Utilizing this operation, these device memory can be used for watchdog monitoring ^{*1} or display scanning ^{*2} .
	Answer-back Device	
	Calendar Device	Use this device memory when the connected device is not equipped with the calendar function and the V9 series built-in clock is not used.

^{*1} Watchdog
When the PLC is communicating with MONITOUCH, there is no means for the PLC to know whether or not MONITOUCH is doing operations correctly. To solve this one-way communication, forcibly change data in the watchdog device memory and check that the same data is saved in the answer back device memory. This proves that the V series is correctly doing operations through communications with the PLC. This verification is called "watchdog".

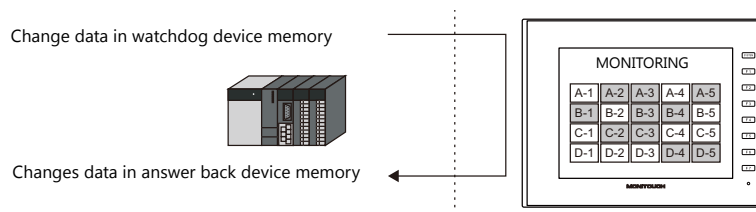

*2 Display scanning

This operation can be utilized for display scanning. Forcibly change data in the watchdog device memory when giving a graphic change command and check that the same data is saved in the answer back device memory. This can prove that the graphic change command is received and executed correctly.

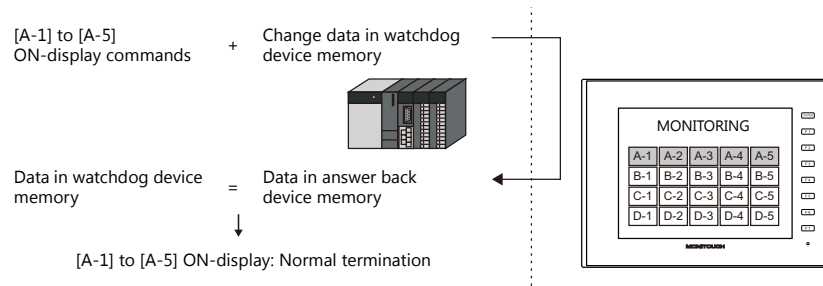
**Calendar device memory**

Follow the steps below to set the calendar.

1. Specify the desired device memory address for [Calendar Device]. Six words are occupied consecutively.
2. Save calendar data in the calendar device memory address specified in step 1 in BCD notation. The address allocation of calendar device memory is shown below.

Device Memory	Contents
n	Year (BCD 0 to 99)
n + 1	Month (BCD 1 to 12)
n + 2	Day (BCD 1 to 31)
n + 3	Hour (BCD 0 to 23)
n + 4	Minute(s) (BCD 0 to 59)
n + 5	Second(s) (BCD 0 to 59)

The day of the week is automatically recognized from the above data. It is not necessary to input any data.

3. Set the calendar read device memory to ON. At the leading edge of this bit (0 → 1), data in the calendar device memory is set for calendar data on MONITOUCH.
- *1 Calendar data is cleared when the power is turned off. When the power is turned on, set calendar data according to the procedure mentioned above.
- *2 When using the calendar device memory, automatic reading of calendar data at the time of PLC connection as well as once-a-day automatic correction is not performed. Consequently, some errors may be introduced. Perform the procedure described above at regular intervals.

Buzzer

Make settings for the buzzer.
For more information, refer to the V9 Series Reference Manual.

Backlight

Make settings for the backlight.
For more information, refer to the V9 Series Reference Manual.

Local IP Address

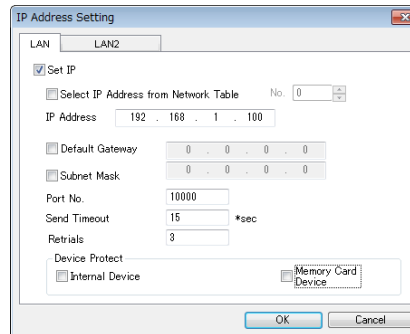

Item	Contents
Select IP Address from Network Table	This is valid when the IP address of the V9 has been registered in the network table. Select a network table number from 0 to 255 to set the IP address. * For more information on the network table, refer to "Network table" (page 1-50).
IP Address* ¹	Set the IP address for the V9.
Default Gateway* ¹	Set the default gateway.
Subnet Mask* ¹	Set the subnet mask. When this box is not checked, the subnet mask is automatically assigned based on the byte at the extreme left of the IP address. Example: When IP address is "172.16.200.185", "255.255.0.0" is set. When IP address is "192.168.1.185", "255.255.255.0" is set.
Port No.* ¹	Set a port number from 1024 to 65535. Other than 8001.
Send Timeout	Specify the timeout time to send the EREAD/EWRITE/SEND/MES command.
Retrials	0 to 255 Set the number of retrials to be performed when a time-out occurs.
Device Protect Internal Device Memory Card Device	Check either check box to write-protect the device memory from computers or other stations.

*¹ For more information on each setting item, see "Basics of ethernet settings" (page 1-51).

Network table

This is an area for registering IP addresses of the MONITOUCH, PC and other devices.

Select [System Setting] → [Ethernet Communication] → [Network Table] and register.

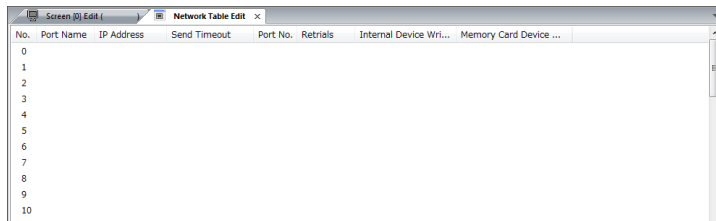

Double-click a number in the No. column to display the [Network Table Setting] dialog. An IP address and other items can be registered.

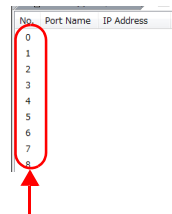

Network table number

Item	Contents
Port Name	Set the name of the V9 or the computer.
IP Address ^{*1}	Set the IP address of the V9 or the computer.
Send Timeout ^{*2}	Specify the timeout time to send the EREAD/EWRITE/SEND/MES command.
Port No. ^{*1}	Set the port number of the V9 or the computer.
Retrials ^{*2}	0 to 255 Set the number of retries to be performed when a time-out occurs.
Device Protect ^{*2} Internal Device Memory Card Device	Check either check box to write-protect the device memory from computers or other stations.
Default Gateway ^{*1 *2}	Set the default gateway.
Subnet Mask ^{*1 *2}	Set the subnet mask.

*1 For more information on each setting item, see "Basics of ethernet settings" (page 1-51).

*2 Invalid if V9 units or PCs at other ports are registered. Only valid when set as the local port IP of the V9 unit.

Basics of ethernet settings

IP address

This is an address that is used for recognizing each node on the Ethernet and should be unique. The IP address is 32-bit data which consists of the network address and the host address and can be classified into classes A to C depending on the network size.

Class A	0	Network address (7)	Host address (24)
Class B	10	Network address (14)	Host address (16)
Class C	110	Network address (14)	Host address (8)

<Notation>

A string of 32-bit data is divided into four, and each segment delimited with a period is in decimal notation.

Example: The IP address in class C shown below is represented as "192.128.1.50".
11000000 10000000 00000001 00110010

<Unusable IP addresses>

- "0" is specified for one byte at the extreme left.
- "127" is specified for one byte at the extreme left (loop back address).
- "224" or more is specified for one byte at the extreme left (for multi-cast or experiment).
- The host address consists of only "0" or "255" (broadcast address).

Example: 0.x.x.x

Example: 127.x.x.x

Example: 224.x.x.x

Example: 128.0.255.255, 192.168.1.0

Port No.

Multiple applications are running on each node, and communications are carried out for each application between the nodes. Consequently, it is necessary to have a means to identify the application that data should be transferred to. The port number works as this identifier. Each port number is 16-bit data (from 0 to 65535).

The V9 series uses the port for screen program transfer (8001), PLC communication (as desired), and the simulator (8020). Set a unique number in the range of 1024 to 65535. For a PLC or a computer, set the port number in the range of 256 to 65535. It is recommended to set a greater number.

Default gateway

A gateway and a router are used for communication between different networks.

The IP address of the gateway (router) should be set to communicate with the node(s) on other networks.

Subnet mask

A subnet mask is used for dividing one network address into multiple networks (subnet).

The subnet is assigned by specifying a part of the host address in the IP address as a subnet address.

Class B	10	Network address (14)	Host address (16)
Subnet mask		255. 255. 255. 0	
		11111111 11111111 11111111 00000000	
		Network address Subnet address Host address	

<Unusable subnet masks>

- All bits are set to "0". 0.0.0.0
- All bits are set to "1". 255.255.255.255

Local Mode Screen

Make prohibition settings for Local mode.

For more information, refer to the V9 Series Reference Manual.

1.4.3 Other Equipment

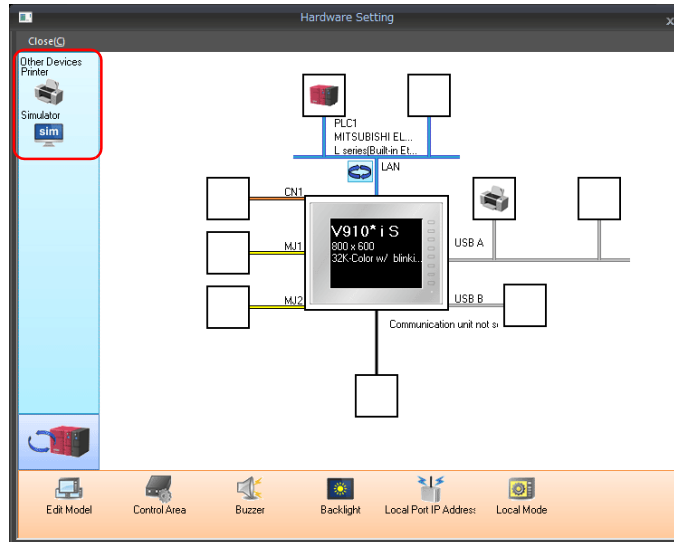

Printer

Configure these settings when connecting a printer.

Selecting the printer model

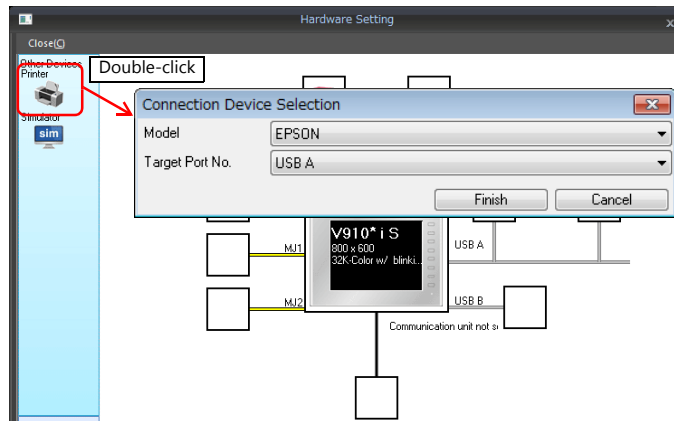

Item	Contents
Model	Select the model of the printer to connect.
Target Port No.	Select the port to connect the printer cable to. USB A: Select when connecting an EPSON, ESC/P-R compatible printer. Also use this setting when connecting a parallel printer using a commercially available parallel-to-USB cable. USB B: Select when connecting a PictBridge-compatible printer. MJ1/MJ2: Select when connecting with the serial interface of a printer. Also select whether to use MJ1 or MJ2 of the V9 series.

Printer properties

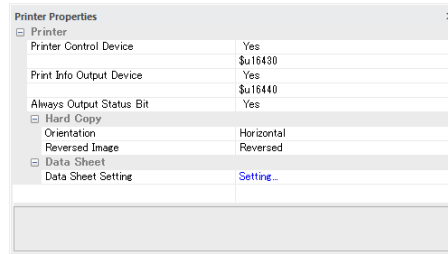

Item	Contents																																
Printer Control Device	<p>When this setting is enabled and the bit is set to ON (0 → 1), screen images and data sheets can be printed out.</p> <p>MSB LSB</p> <table border="1" style="width: 100%; text-align: center;"> <tr> <td>15</td><td>14</td><td>13</td><td>12</td><td>11</td><td>10</td><td>09</td><td>08</td><td>07</td><td>06</td><td>05</td><td>04</td><td>03</td><td>02</td><td>01</td><td>00</td> </tr> <tr> <td>0</td><td>0</td><td>0</td><td>0</td><td>0</td><td>0</td><td>0</td><td>0</td><td>0</td><td>0</td><td>0</td><td>0</td><td>0</td><td>0</td><td>0</td><td>0</td> </tr> </table> <p style="text-align: right;">0 → 1: Screen image output 0 → 1: Data sheet output</p>	15	14	13	12	11	10	09	08	07	06	05	04	03	02	01	00	0	0	0	0	0	0	0	0	0	0	0	0	0	0	0	0
15	14	13	12	11	10	09	08	07	06	05	04	03	02	01	00																		
0	0	0	0	0	0	0	0	0	0	0	0	0	0	0	0																		
Printer Info Output Device	<p>When this setting is enabled, the status of the printer is stored in the specified address.</p> <p>MSB LSB</p> <table border="1" style="width: 100%; text-align: center;"> <tr> <td>15</td><td>14</td><td>13</td><td>12</td><td>11</td><td>10</td><td>09</td><td>08</td><td>07</td><td>06</td><td>05</td><td>04</td><td>03</td><td>02</td><td>01</td><td>00</td> </tr> <tr> <td>0</td><td>0</td><td>0</td><td>0</td><td>0</td><td>0</td><td>0</td><td>0</td><td>0</td><td>0</td><td>0</td><td>0</td><td>0</td><td>0</td><td>0</td><td>0</td> </tr> </table> <p style="text-align: right;">0: End (standby) 1: Transferring print data 0: Not busy status 1: Busy status</p>	15	14	13	12	11	10	09	08	07	06	05	04	03	02	01	00	0	0	0	0	0	0	0	0	0	0	0	0	0	0	0	0
15	14	13	12	11	10	09	08	07	06	05	04	03	02	01	00																		
0	0	0	0	0	0	0	0	0	0	0	0	0	0	0	0																		
Always Output Status Bit	<p>The V9 series outputs [0 → 1] when starting to transfer data upon receiving a print command, and outputs [1 → 0] upon finishing transfer. However, these signals may not be output if the print data is small. Select [Yes] to output a signal regardless of the data size.</p> <p>The output area is as follows:</p> <ul style="list-style-type: none"> • Bit 1 of the device memory for printer information output • Bit 0 of internal device memory \$s16 <p>\$s16</p> <p>MSB LSB</p> <table border="1" style="width: 100%; text-align: center;"> <tr> <td>15</td><td>14</td><td>13</td><td>12</td><td>11</td><td>10</td><td>09</td><td>08</td><td>07</td><td>06</td><td>05</td><td>04</td><td>03</td><td>02</td><td>01</td><td>00</td> </tr> <tr> <td>0</td><td>0</td><td>0</td><td>0</td><td>0</td><td>0</td><td>0</td><td>0</td><td>0</td><td>0</td><td>0</td><td>0</td><td>0</td><td>0</td><td>0</td><td>0</td> </tr> </table> <p style="text-align: right;">0: End (standby) 1: Transferring print data</p>	15	14	13	12	11	10	09	08	07	06	05	04	03	02	01	00	0	0	0	0	0	0	0	0	0	0	0	0	0	0	0	0
15	14	13	12	11	10	09	08	07	06	05	04	03	02	01	00																		
0	0	0	0	0	0	0	0	0	0	0	0	0	0	0	0																		
Hard Copy	<p>Orientation</p> <p>Specify the printing orientation of the screen on paper. In vertical output, the screen is rotated 90° clockwise with respect to the printing paper and printed out.</p> <ul style="list-style-type: none"> • Printing examples of hard copies: <div style="display: flex; justify-content: space-around; align-items: center;"> <div style="text-align: center;"> <p>Horizontal</p> </div> <div style="text-align: center;"> <p>Vertical</p> </div> </div>																																
	<p>Reversed Image</p> <p>Reversed: Screens are printed with black and white inverted. Normal: Screens are printed as they are displayed on MONITOUCH.</p>																																
Data Sheet	<p>Data Sheet Setting</p> <p>Make settings for printing data sheets. For more information, refer to the V9 Series Reference Manual.</p>																																
<p>Use PictBridge only on USB-B port.</p> <p>Make this setting when using a PictBridge-compatible printer. Select [Yes] when starting up the USB-B port as the connection port for a PictBridge printer in the RUN mode. When transferring screen programs via the USB-B port, switch to Local mode.</p>																																	

Item		Contents
Serial Port	Baud Rate	Set the communication baud rate. 4800/9600/19200/38400/57600/76800/115K BPS
	Parity	Select an option for parity bit. None / Odd / Even
	Data Length	Select a data length. 7 bits / 8 bits
	Stop Bit	Select a stop bit. 1 bit / 2 bits

* For details on printing, refer to the V9 Series Reference Manual.

Touch Switch (CH5)

Configure this setting when emulating touch switches on the RGB input screen.
The optional unit "GUR-01/GUR-10/GUR-11" (under development) is required for RGB input display.
For details on touch switch emulation, refer to the V9 Series Reference Manual.

Simulator

Configure this setting when saving a simulator communication program to a storage device (SD card or USB flash drive) in addition to screen program data using the storage manager.

1.5 System Device Memory for Communication Confirmation

The V9 series has addresses \$s and \$Pn as system device memory.

- \$Pn
This is the system device memory for 8-way communications, and 512 words are allocated for each logical port. For more information, see "1.5.1 \$Pn (For 8-way Communication)".
- \$s518
This is the system device memory for confirming the Ethernet status. For more information, see "1.5.2 \$s518 (Ethernet Status Confirmation)".

For the device memory address \$s, \$s0 to 2047 (2 K words) are assigned and data can be read from written to this area. For more information on addresses other than \$s518, refer to the V9 Series Reference Manual.

1.5.1 \$Pn (For 8-way Communication)

This is the system device memory for 8-way communications, and 512 words are assigned for each logical port. Refer to the next section for more information.

\$P1: 0000 : \$P1: 0511	PLC1 area
\$P2: 0000 : \$P2: 0511	PLC2 area
\$P3: 0000 : \$P3: 0511	PLC3 area
\$P4: 0000 : \$P4: 0511	PLC4 area
\$P5: 0000 : \$P5: 0511	PLC5 area
\$P6: 0000 : \$P6: 0511	PLC6 area
\$P7: 0000 : \$P7: 0511	PLC7 area
\$P8: 0000 : \$P8: 0511	PLC8 area

\$Pn List

The \$Pn list is presented below. Part of the information of logical ports PLC1/PLC2 can also be stored in \$s.^{*1}

\$Pn (n = 1 to 8)	\$s ^{*1}	Contents	Device Type
000	111 (PLC1)	V9 local port number Stores the local port number of the V9 series. (Universal serial communication, slave communication, etc.)	←V
:	-	:	
004	130 (PLC1) ^{*2}	Modbus TCP/IP Sub Station communications Relay station No. designated device memory When a relay station number is set with a MOV macro command, the error information of the sub station number that is connected to that relay station is stored in \$Pn010 to 025.	→V
:	-	:	
010	128 (PLC1)	Link down information (station No. 0 - 15) 0: Normal 1: Down	←V
011	129 (PLC1)	Link down information (station No. 16 - 31) 0: Normal 1: Down	
012	114 (PLC1)	Link down information (station No. 32 - 47) 0: Normal 1: Down	
013	115 (PLC1)	Link down information (station No. 48 - 63) 0: Normal 1: Down	
014	116 (PLC1)	Link down information (station No. 64 - 79) 0: Normal 1: Down	
015	117 (PLC1)	Link down information (station No. 80 - 95) 0: Normal 1: Down	
016	118 (PLC1)	Link down information (station No. 96 - 111) 0: Normal 1: Down	
017	119 (PLC1)	Link down information (station No. 112 - 127) 0: Normal 1: Down	
018	120 (PLC1)	Link down information (station No. 128 - 143) 0: Normal 1: Down	
019	121 (PLC1)	Link down information (station No. 144 - 159) 0: Normal 1: Down	
020	122 (PLC1)	Link down information (station No. 160 - 175) 0: Normal 1: Down	
021	123 (PLC1)	Link down information (station No. 176 - 191) 0: Normal 1: Down	
022	124 (PLC1)	Link down information (station No. 192 - 207) 0: Normal 1: Down	
023	125 (PLC1)	Link down information (station No. 208 - 223) 0: Normal 1: Down	
024	126 (PLC1)	Link down information (station No. 224 - 239) 0: Normal 1: Down	
025	127 (PLC1)	Link down information (station No. 240 - 255) 0: Normal 1: Down	
:	-	:	
099	-	Error information hold (page 1-59) Setting for the update timing of the \$Pn: 010 to 025 link down information 0: Always updated with the latest information Other than 0: Only updated when a communication error occurs	→V
100	730 (PLC2)	Error status Station No. 00 status (page 1-60)	←V
101	731 (PLC2)	Error status Station No. 01 status (page 1-60)	
102	732 (PLC2)	Error status Station No. 02 status (page 1-60)	
103	733 (PLC2)	Error status Station No. 03 status (page 1-60)	
104	734 (PLC2)	Error status Station No. 04 status (page 1-60)	
105	735 (PLC2)	Error status Station No. 05 status (page 1-60)	
106	736 (PLC2)	Error status Station No. 06 status (page 1-60)	
107	737 (PLC2)	Error status Station No. 07 status (page 1-60)	
108	738 (PLC2)	Error status Station No. 08 status (page 1-60)	
109	739 (PLC2)	Error status Station No. 09 status (page 1-60)	

\$Pn (n = 1 to 8)	\$s*1	Contents	Device Type	
110	740 (PLC2)	Error status Station No. 10 status (page 1-60)	←V	
:	:	:		
120	750 (PLC2)	Error status Station No. 20 status (page 1-60)		
:	:	:		
130	760 (PLC2)	Error status Station No. 30 status (page 1-60)		
131	761 (PLC2)	Error status Station No. 31 status (page 1-60)		
132	820 (PLC2)	Error status Station No. 32 status (page 1-60)		
133	821 (PLC2)	Error status Station No. 33 status (page 1-60)		
:	:	:		
140	828 (PLC2)	Error status Station No. 40 status (page 1-60)		
:	:	:		
150	838 (PLC2)	Error status Station No. 50 status (page 1-60)		
:	:	:		
160	848 (PLC2)	Error status Station No. 60 status (page 1-60)		
:	:	:		
170	858 (PLC2)	Error status Station No. 70 status (page 1-60)		
:	:	:		
180	868 (PLC2)	Error status Station No. 80 status (page 1-60)		
:	:	:		
190	878 (PLC2)	Error status Station No. 90 status (page 1-60)		
:	:	:		
199	887 (PLC2)	Error status Station No. 99 status (page 1-60)		
200	-	Error status Station No. 100 status (page 1-60)		
:	:	:		
350	-	Error status Station No. 250 status (page 1-60)		
:	:	:		
355	-	Error status Station No. 255 status (page 1-60)		
356	-	Device memory map 0 Status		←V
357	-	Device memory map 0 Error code 1		
358	-	Device memory map 0 Error code 2		
359-361	-	Device memory map 1 Status, error code		
362-364	-	Device memory map 2 Status, error code		
365-367	-	Device memory map 3 Status, error code		
368-370	-	Device memory map 4 Status, error code		
371-373	-	Device memory map 5 Status, error code		
374-376	-	Device memory map 6 Status, error code		
377-379	-	Device memory map 7 Status, error code		
380-382	-	Device memory map 8 Status, error code		
383-385	-	Device memory map 9 Status, error code		
386-388	-	Device memory map 10 Status, error code		
389-391	-	Device memory map 11 Status, error code		
392-394	-	Device memory map 12 Status, error code		
395-397	-	Device memory map 13 Status, error code		
398-400	-	Device memory map 14 Status, error code		
401-403	-	Device memory map 15 Status, error code		
404-406	-	Device memory map 16 Status, error code		
407-409	-	Device memory map 17 Status, error code		
410-412	-	Device memory map 18 Status, error code		
413-415	-	Device memory map 19 Status, error code		
416-418	-	Device memory map 20 Status, error code		

\$Pn (n = 1 to 8)	\$s ^{*1}	Contents	Device Type
419-421	-	Device memory map 21 Status, error code	←V
422-424	-	Device memory map 22 Status, error code	
425-427	-	Device memory map 23 Status, error code	
428-430	-	Device memory map 24 Status, error code	
431-433	-	Device memory map 25 Status, error code	
434-436	-	Device memory map 26 Status, error code	
437-439	-	Device memory map 27 Status, error code	
440-442	-	Device memory map 28 Status, error code	
443-445	-	Device memory map 29 Status, error code	
446-448	-	Device memory map 30 Status, error code	
449	-	Device memory map 31 Status	
450	-	Device memory map 31 Error code 1	
451	-	Device memory map 31 Error code 2	
:	:	:	
493	762 (PLC2) ^{*3}	Device memory map reading prohibited flag (refer to the V9 Series Reference Manual). 0: Periodical reading/synchronized reading executed Other than 0: Periodical reading/synchronized reading stopped	→V
494	763 (PLC2) ^{*3}	Forced execution of the device memory map TRL_READ/TBL_WRITE macro Setting for macro operation when there is a station with a communication error 0: The macro is not executed in relation to any of the stations. Other than 0: The macro is executed in relation to connected stations.	
495	764 (PLC2) ^{*3}	Device memory map writing prohibited flag (refer to the V9 Series Reference Manual). 0: Periodical writing/synchronized writing executed Other than 0: Periodical writing/synchronized writing stopped	
:	-	:	
500	800 (PLC3)	Device memory for Modbus slave communications Used for setting the number of the reference device memory map and the device memory for referring free area 31.Used for setting the number of the reference device memory map and the device memory for referring free area 31. \$Pn500 to 505 are exclusively used for monitoring: \$s800 to 805 are used for writing from the Modbus master. Refer to the Modbus Slave Communication Specifications.	→V
501	801 (PLC3)		
502	802 (PLC3)		
503	803 (PLC3)		
504	804 (PLC3)		
505	805 (PLC3)		
:	:	:	
508	765 (PLC2)	Error response code (page 1-62) If "800BH" (error code received) is stored for the error status (\$Pn100 to 355), it is possible to check the error code.	←V
509	766 (PLC2)		
510	767 (PLC2)		
511	768 (PLC2)		

*1 For PLC1, select [Yes] for [System memory (\$s) V7 Compatible] under [Detail] on the [PLC Properties] window. The same information is stored in the \$P1 and \$s.

*2 If designating the relay station number using \$s130, select [Yes] for [System memory (\$s) V7 Compatible] under [Detail] on the [PLC Properties] window for PLC1. \$P1: 004 cannot be used in this case.

*3 If executing device memory map control using \$s762, \$s763 and \$s764, select yes for [System memory (\$s) V7 Compatible] under [Detail] on the [PLC Properties] window for PLC2. Note that \$P2: 493/494/495 cannot be used in this case.

Details

\$Pn:99

The update timing for the link down information stored in \$Pn:010 to 025 is set here.

- 0: Always updated with the latest information
- Other than 0: Only updated when a communication error occurs

- Example:

An error has occurred at station No. 18. 2nd bit of \$Pn: 011 is set (ON).

	Station No. 31										Station No. 16					
	15	14	13	12	11	10	9	8	7	6	5	4	3	2	1	0
\$Pn: 011	0	0	0	0	0	0	0	0	0	0	0	0	0	1	0	0

↓
↓

Station No. 18 Link down

After resetting communications

- If \$Pn: 99 = 0, the link down information is updated.

	Station No. 31										Station No. 16					
	15	14	13	12	11	10	9	8	7	6	5	4	3	2	1	0
\$Pn: 011	0	0	0	0	0	0	0	0	0	0	0	0	0	0	0	0

↓

Station No. 18 Normal communication

- If \$Pn: 99 = other than 0, the link down information is not updated.

	Station No. 31										Station No. 16					
	15	14	13	12	11	10	9	8	7	6	5	4	3	2	1	0
\$Pn: 011	0	0	0	0	0	0	0	0	0	0	0	0	0	1	0	0

↓

Station No. 18 Link down

\$Pn: 100 to 355

The results of communication with each station are stored here. The status codes are shown below.

Code (HEX)	Contents
0000H	Normal
FFFFH	Time-out
8001H	Check code error
8002H	Data error
800BH	Receives the error code from the connected device

Errors other than the above are stored as shown below.

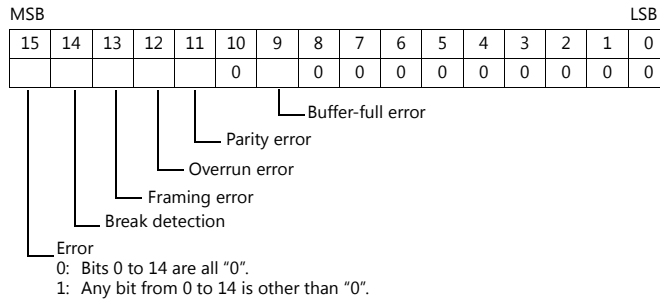

Error	Details	Solution
Time-out	Although a request to send is given, no answer is returned within the specified time.	Implement solutions 1, 2, and 3.
Check code	The check code of the response is incorrect.	Implement solutions 1 and 3.
Data error	The code of the received data is invalid.	Implement solutions 1, 2, and 3.
Error code received	An error occurred on the connected device.	Refer to the instruction manual for the PLC.
Buffer full	The V9 buffer is full.	Contact your local distributor.
Parity	An error occurred in parity check.	Implement solutions 2 and 3.
Overrun	After receiving one character, the next character was received before internal processing was completed.	Implement solutions 1 and 3.
Framing	Although the stop bit must be "1", it was detected as "0".	Implement solutions 1, 2, and 3.
Break detection	The connected device's SD is remaining at the low level.	Examine the connection with the connected device's SD and RD.

- Solution

- 1) Check if the communication settings of the V9 series and the connected device are matched.
 - 2) Check the cable connection.
 - 3) Data may be disrupted because of noise. Fix noise.
- If you still cannot solve the error even after following the solutions above, contact your local distributor.

\$Pn: 356 to 451

This device memory is valid when an Omron ID controller (V600/620/680) is connected with [Guarantee synchronism of the data] checked on the [Device Memory Map Setting] dialog.

- Status (\$Pn 356, 359, ...)

The execution status of the device memory map is stored here.

The bit is set (ON) when reading or writing of the first data in the device memory map is correctly finished.

When the control device memory (command bit) is set (ON), the bit is reset.

15	14	13	12	11	10	9	8	7	6	5	4	3	2	1	0
0	0	0	0	0	0	0	0	0	0	0	0	0	1	0	0

System reserve
1: ID tag recognized

- Error code 1 (\$Pn 357, 360, ...)

An error code is stored when an error occurs in the reading or writing of data in the device memory map.

If multiple errors occur in the device memory map, the last error code is stored.

When the control device memory (command bit) is set (ON), the bit is reset.

Code (HEX)	Contents
FFFFH	Time-out
8001H	Check code error
8002H	Data error
800BH	Receives the error code from the connected device

Errors other than the above are stored as shown below.

MSB	15	14	13	12	11	10	9	8	7	6	5	4	3	2	1	0	LSB
						0		0	0	0	0	0	0	0	0	0	

Error
 0: Bits 0 to 14 are all "0".
 1: Any bit from 0 to 14 is other than "0".

Buffer-full error (bits 8-10)
 Parity error (bits 11-12)
 Overrun error (bits 12-13)
 Framing error (bits 13-14)
 Break detection (bits 14-15)

- Error code 2 (\$Pn 358, 361, ...)

The exit code is stored here when "800BH" of error code 1 is stored.

Exit Code (HEX)	Contents
10	Parity error
11	Framing error
12	Overrun error
13	FCS error
14	Format error, execution status error
18	Frame length error
70	Tag communication error
71	Inconsistency error
72	Tag absence error
76	Copy error
7A	Address error
7C	Antenna disconnection error
7D	Write protect error
75	Tag device memory warning Exit code stored when the writing count management command has been successfully processed (without any error)
76	Data check command Exit code stored when the writing count management command has abnormally been processed (comparison error, excessive writing counts)
92	System error Abnormal mains voltage at antenna
93	Internal device memory error

\$Pn: 508 to 511

If "800BH" is stored for the error status information (\$Pn: 100 to 355), on transferring the data of that station number to any internal device memory address, the reception code will be obtained at \$Pn: 508 to 511.

Notes on use

- Use \$u/\$T as the target internal device memory.
- Use the macro command MOV (W). MOV (D) cannot be used.
- "0" is stored to device memory addresses that have no expansion error code.

- Example PLC2: Fuji Electric PXR station No. 1

- 1) On receipt of an error code at station No. 1 of PLC2, "800BH" is stored in \$P2:101.

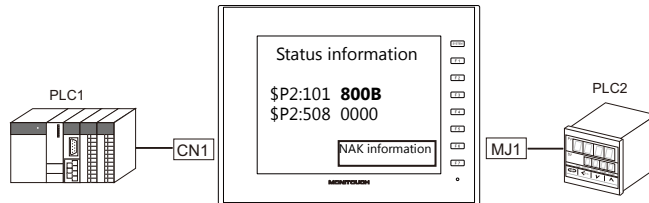

- 2) The data of \$P2: 101 is transferred to \$u1000 by a MOV command.
\$u1000 = \$P2: 101 (W)

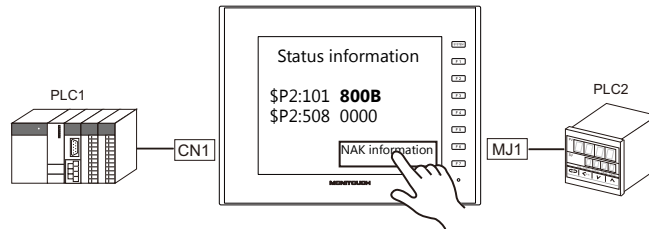

- 3) The reception code is stored in \$P2: 508.
\$P2:508 = 0002H

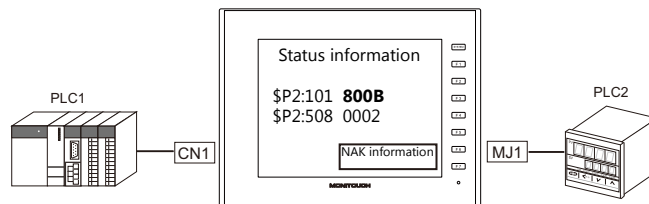

- 4) The PXR manual shows that code 002H means "device memory address range exceeded". Amend the screen program address designation.

1.5.2 \$s518 (Ethernet Status Confirmation)

Stores the current status of the Ethernet.

Address	Contents	Stored Value
\$s518	Ethernet status (for built-in LAN port)	<ul style="list-style-type: none"> • [0]: Normal • [Other than 0]: Error * For details on errors, refer to the next section.

Error details

No.	Built-in LAN	Contents	Solution
201	○	Send error	Check that the setting on the target station is consistent with the network table setting.
203	○	TCP socket creation error	The TCP socket cannot be created. Turn the power off and back on again, or check the communication line status, e.g., if the port number is duplicated.
204	○	TCP connection over	The number of connections reaches the maximum (256), and no more connection is possible. Check the communication lines.
205	○	TCP connection error	Connection cannot be established. Check the communication lines, or turn the power off and back on again.
207	○	TCP send error	TCP communication has failed. Check the communication lines.
208	○	TCP connection interruption notification from the connected device	Check the connected device and communication lines.
261	○	Send processing full error	Sending process is disabled. Check the communication lines.
350	○	Send buffer full	The line is busy. Consult the network administrator of your company. The communication unit is of an old version or is faulty.
801	○	Link down error	Check the HUB or the link confirmation LED on the communication unit. If the LED is not on, check cable connection and the port setting on the network table.
1202	○	MAC address error	The MAC address is not registered. Repair is necessary.
2001	○	Undefined error	Turn the power off and back on again. If the problem persists, the unit may be faulty. Contact your local distributor.

MEMO

Please use this page freely.

2. IAI

2.1 Temperature Controller/Servo/Inverter Connection

2.1 Temperature Controller/Servo/Inverter Connection

Serial Connection

X-SEL Controller

PLC Selection on the Editor	Model		Port	Signal Level	Connection		Lst File
					CN1	MJ1/MJ2	
X-SEL Controller	Orthogonal	XSEL-K XSEL-KE XSEL-KT/KET	HOST port	RS-232C	Wiring diagram 1 - C2	Wiring diagram 1 - M2	IAI-XSEL.Lst
	Scalar	XSEL-KX					
	Orthogonal	XSEL-J XSEL-P XSEL-Q	TP port	RS-232C	Wiring diagram 2 - C2	Wiring diagram 2 - M2	
	Scalar	XSEL-JX XSEL-PX XSEL-QX					

Robo Cylinder

PLC Selection on the Editor	Model	Port	Signal Level	Connection		Lst File
				CN1	MJ1/MJ2	
ROBO CYLINDER (RCP2/ERC)	RCP2 ERC	SIO	RS-485	Wiring diagram 1 - C4	Wiring diagram 1 - M4	IAI_ROBO.Lst
			RS-232C	Wiring diagram 3 - C2 ^{*1}	Wiring diagram 3 - M2 ^{*1}	
				Wiring diagram 4 - C2 ^{*2}	Wiring diagram 4 - M2 ^{*2}	
ROBO CYLINDER (RCS/E-CON)	RCS E-CON	PORT IN	RS-485	Wiring diagram 1 - C4	Wiring diagram 1 - M4	IAI_ROBO.Lst
			RS-232C	Wiring diagram 3 - C2 ^{*1}	Wiring diagram 3 - M2 ^{*1}	
				Wiring diagram 4 - C2 ^{*2}	Wiring diagram 4 - M2 ^{*2}	
PCON/ACON/SCON (MODBUS RTU)	PCON ACON SCON	SIO	RS-485	Wiring diagram 1 - C4	Wiring diagram 1 - M4	IAI_PCON.Lst
			RS-232C	Wiring diagram 3 - C2 ^{*1}	Wiring diagram 3 - M2 ^{*1}	
				Wiring diagram 4 - C2 ^{*2}	Wiring diagram 4 - M2 ^{*2}	

*1 Use the IAI's RS-485 conversion adaptor "RCB-CV-MW" and IAI's external device communication cable "CB-RCA-SIO020 (050)".

*2 Use the IAI's SIO converter "RCB-TU-SIO-A/B".

2.1.1 X-SEL Controller

Communication Setting

Editor

Communication setting

(Underlined setting: default)

Item	Setting	Remarks
Connection Mode	1 : 1 / <u>1 : n</u> / Multi-link2 / Multi-link2 (Ethernet) / 1 : n Multi-link2 (Ethernet)	
Signal Level	RS-232C / RS-422/485	
Baud Rate	9600 / 19200 / <u>38400</u> / 57600 / 115K bps	
Data Length	8 bits	
Stop Bit	1 bit	
Parity	None	
Target Port No.	0 to 31	

X-SEL Controller

Application software

Set parameters using the application software.

(Underlined setting: default)

Parameter	Parameter Name	Setting
I/O parameter 90	Channel 1 usage	2 (IAI protocol B)
I/O parameter 91	Channel 1 code	0 to 31
I/O parameter 92	Baud rate	<u>9600</u> / 19200 / 38400 bps
I/O parameter 93	Data length	8
I/O parameter 94	Stop bit	1
I/O parameter 95	Parity	None
Other parameter 46	Bit pattern	1

Mode switch

Select [AUTO].

System I/O connector

If the servo cannot be turned on, check the wiring of the system I/O connector.

- XSEL-K/KE/KT/KET/KX/J/JX (with built-in cutout relay)**
 Set the normally-closed type emergency stop input between the EMG terminals or short-circuit these terminals. When they are open, operation is disabled due to an emergency stop.
 For the ENB terminals, set the normally-closed safety gate input or short-circuit them. When they are open, operation is disabled due to the shutout of the power.
- XSEL-P/PX (with built-in cutout relay)**
 Short-circuit terminals of "EMG1 line+" and "EMGin +24V". For "EMG1 line-" and "EMGin IN", connect the normally-closed type emergency stop switch or short-circuit them. When they are open, operation is disabled due to an emergency stop.
 Short-circuit terminals of "ENB1 line+" and "ENBin +24V". For "ENB1 line-" and "ENBin IN", connect the normally-closed type enable switch or short-circuit them. When they are open, operation is disabled due to the shutout of the power.
- XSEL-Q/QX (with external cutout relay)**
 Install wiring by referring to the specifications sheet of X-SEL.

Available Device Memory

The available setting range of device memory varies depending on the model. Be sure to set within the range available for the model to be used. Use [TYPE] when assigning indirect device memory for macro programs.

Device Memory	TYPE	Remarks
20B (input port)	00H	Read only, virtual input port not available
20C (output port)	01H	Virtual output port not available
20D (flag)	02H	
20E (integer variable) *1	03H	Double-word
210 (string) *2	04H	
208 (effective point data count)	05H	Read only
212 (axis status)	06H	Double-word, read only
213 (program status)	07H	Read only
215 (system status)	08H	Read only
253 (program)	09H	Write only
2A1 (scalar axis status)	0AH	Double-word, read only

*1 For 20E (integer variable) XYYYY

Variable number 0000 to 4095
Program number 00 to 99

*2 For 210 (string) XYYYY

Column number 0000 to 4095
Program number 00 to 99

208 (Effective Point Data Count)

Address	Name
0	Effective point data count

212 (Axis Status)

Address	Name
0	Axis 1 axis status
1	Axis 1 axis sensor input status
2	Axis 1 axis-related error code
3	Axis 1 encoder status
4	Axis 1 current position
10	Axis 2 axis status
11	Axis 2 axis sensor input status
12	Axis 2 axis-related error code
13	Axis 2 encoder status
14	Axis 2 current position
20	Axis 3 axis status
21	Axis 3 axis sensor input status
22	Axis 3 axis-related error code
23	Axis 3 encoder status
24	Axis 3 current position
30	Axis 4 axis status
31	Axis 4 axis sensor input status
32	Axis 4 axis-related error code
33	Axis 4 encoder status
34	Axis 4 current position

213 (Program Status)

Address	Name
0	Status
1	Running program step number
2	Program-sensitive error code
3	Error occurrence step

215 (System Status)

Address	Name
0	System mode
1	Most significant level system error number
2	Most recent system error number
3	System status byte 1
4	System status byte 2
5	System status byte 3
6	System status byte 4

253 (Program)

Address	Name	Value
Program number	Program	0: Program end 1: Program execution 2: Program pause 3: Program one step execution 4: Program execution restart

2A1 (Scalar Axis Status)

Address	Name
0	Workpiece coordinate system number
1	Tool coordinate system number
2	Axis common status
3	Axis 1 axis status
4	Axis 1 axis sensor input status
5	Axis 1 axis-related error code
6	Axis 1 encoder status
7	Axis 1 current position
10	Workpiece coordinate system number
11	Tool coordinate system number
12	Axis common status
13	Axis 2 axis status
14	Axis 2 axis sensor input status
15	Axis 2 axis-related error code
16	Axis 2 encoder status
17	Axis 2 current position
20	Workpiece coordinate system number
21	Tool coordinate system number
22	Axis common status
23	Axis 3 axis status
24	Axis 3 axis sensor input status
25	Axis 3 axis-related error code
26	Axis 3 encoder status
27	Axis 3 current position
30	Workpiece coordinate system number
31	Tool coordinate system number
32	Axis common status
33	Axis 4 axis status
34	Axis 4 axis sensor input status
35	Axis 4 axis-related error code
36	Axis 4 encoder status
37	Axis 4 current position

PLC_CTL

Real numbers used on the V series are IEEE 32-bit single precision ones.

Contents	F0	F1 (= \$u n)		F2									
Version inquiry	1 - 8 (PLC1 - 8)	n	Station number	4									
		n + 1	Command: 201 (HEX)										
		n + 2	Unit type 0: Main CPU application area 1: Main CPU core area 2: Driver CPU										
		n + 3	Device number										
		n + 4	Model code										
		n + 5	Unit code										
		n + 6	Version number										
		n + 7	Year (4-digit)										
		n + 8	Month										
		n + 9	Day										
		n + 10	Hour										
		n + 11	Minute										
		n + 12	Second										
Effective point data count inquiry	1 - 8 (PLC1 - 8)	n	Station number	2									
		n + 1	Command: 208 (HEX)										
		n + 2	Effective point data count										
Effective point data inquiry	1 - 8 (PLC1 - 8)	n	Station number	3									
		n + 1	Command: 209 (HEX)										
		n + 2	Inquiry point number										
		n + 3	Effective point data count										
		n + 4	Point number										
		n + 5	Axis pattern: m (number of ON bits) Bit <table border="1" style="display: inline-table; vertical-align: middle;"> <tr><td>-</td><td>7</td><td>6</td><td>5</td><td>4</td><td>3</td><td>2</td><td>1</td><td>0</td></tr> </table> ↳ Axis 1 : ↳ Axis 6		-	7	6	5	4	3	2	1	0
		-	7		6	5	4	3	2	1	0		
		n + 6	Acceleration										
		n + 7	Deceleration										
		n + 8	Speed										
		n + 9 to n + 10	Axis pattern 1		Position data								
n + 11 -	:	:											
n + 11 -	Axis pattern m	Position data											
Real variable inquiry Disabled for X-SEL version 0.41 or earlier	1 - 8 (PLC1 - 8)	n	Station number	5									
		n + 1	Command: 20F (HEX)										
		n + 2	Program number										
		n + 3	Inquiry start variable number										
		n + 4	Inquiry data count: m (1 to 10)										
		n + 5	Response start variable number										
		n + 6	Response variable data count: m										
		n + 7 to n + 8	Data count 1		Data for variable								
		n + 9 -	:		:								
n + 9 -	Data count m	Data for variable											
Axis status inquiry For orthogonal	1 - 8 (PLC1 - 8)	n	Station number	3									
		n + 1	Command: 212 (HEX)										
		n + 2	Inquiry axis pattern: m (number of ON bits) Bit <table border="1" style="display: inline-table; vertical-align: middle;"> <tr><td>-</td><td>7</td><td>6</td><td>5</td><td>4</td><td>3</td><td>2</td><td>1</td><td>0</td></tr> </table> ↳ Axis 1 : ↳ Axis 6		-	7	6	5	4	3	2	1	0
		-	7		6	5	4	3	2	1	0		
		n + 3	Status m = 1		Axis status								
		n + 4			Axis sensor input status								
		n + 5			Axis-related error code								
		n + 6			Encoder status								
		n + 7 to n + 8			Current position								
		n + 9 -	Status (m = 2)		:								
n + 9 -	:	:											

Contents	F0	F1 (= \$u n)		F2									
Program status inquiry	1 - 8 (PLC1 - 8)	n	Station number	3									
		n + 1	Command: 213 (HEX)										
		n + 2	Program number										
		n + 3	Status										
		n + 4	Running program step number										
		n + 5	Program-sensitive error code										
System status inquiry	1 - 8 (PLC1 - 8)	n	Station number	2									
		n + 1	Command: 215 (HEX)										
		n + 2	System mode										
		n + 3	Most significant level system error number										
		n + 4	Most recent system error number										
		n + 5	System status byte 1										
		n + 6	System status byte 2										
		n + 7	System status byte 3										
Error detailed information inquiry	1 - 8 (PLC1 - 8)	n	Station number	5									
		n + 1	Command: 216 (HEX)										
		n + 2	Type 1 0: System error 1: Axis error 2: Program error 3: Error in error list record										
		n + 3	Type 2 In the event of a system error: 0: Most significant level error 1: Most recent error In the event of an axis error: Axis number In the event of a program error: Program number In the event of an error in error list record: Record number										
		n + 4	Error number										
		n + 5 to n + 6	Detailed information 1										
		n + 7 to n + 8	Detailed information 2										
		n + 9 to n + 10	Detailed information 3										
		n + 11 to n + 12	Detailed information 4										
		n + 13 to n + 14	Detailed information 5										
		n + 15 to n + 16	Detailed information 6										
		n + 17 to n + 18	Detailed information 7										
		n + 19 to n + 20	Detailed information 8										
		n + 21 to n + 27	System reserved										
		n + 28	Number of message bytes										
n + 29 -	Message character string (equivalent to message bytes)												
Servo ON/OFF	1 - 8 (PLC1 - 8)	n	Station number	4									
		n + 1	Command: 232 (HEX)										
		n + 2	Axis pattern <div style="display: flex; align-items: center; margin-left: 40px;"> Bit <table border="1" style="border-collapse: collapse; text-align: center;"> <tr> <td style="width: 15px;">-</td> <td style="width: 15px;">7</td> <td style="width: 15px;">6</td> <td style="width: 15px;">5</td> <td style="width: 15px;">4</td> <td style="width: 15px;">3</td> <td style="width: 15px;">2</td> <td style="width: 15px;">1</td> <td style="width: 15px;">0</td> </tr> </table> <div style="margin-left: 10px;"> } Axis 1 } Axis 6 </div> </div>		-	7	6	5	4	3	2	1	0
		-	7		6	5	4	3	2	1	0		
n + 3	Servo 0: OFF 1: ON												
Origin return For orthogonal	1 - 8 (PLC1 - 8)	n	Station number	5									
		n + 1	Command: 233 (HEX)										
		n + 2	Axis pattern <div style="display: flex; align-items: center; margin-left: 40px;"> Bit <table border="1" style="border-collapse: collapse; text-align: center;"> <tr> <td style="width: 15px;">-</td> <td style="width: 15px;">7</td> <td style="width: 15px;">6</td> <td style="width: 15px;">5</td> <td style="width: 15px;">4</td> <td style="width: 15px;">3</td> <td style="width: 15px;">2</td> <td style="width: 15px;">1</td> <td style="width: 15px;">0</td> </tr> </table> <div style="margin-left: 10px;"> } Axis 1 } Axis 6 </div> </div>		-	7	6	5	4	3	2	1	0
		-	7		6	5	4	3	2	1	0		
n + 3	End search speed for origin return (mm/sec)												
n + 4	Creep speed for origin return (mm/sec)												

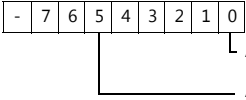
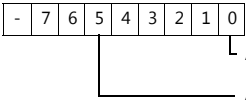
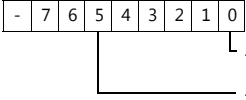
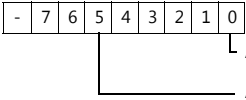
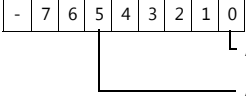
Contents	F0	F1 (= \$u n)	F2	
Traverse by absolute command For orthogonal	1 - 8 (PLC1 - 8)	n	Station number	6 + 2m
		n + 1	Command: 234 (HEX)	
		n + 2	Axis pattern: m (number of ON bits)	
			Bit 	
		n + 3	Acceleration	
		n + 4	Deceleration	
		n + 5	Speed	
		n + 6 to n + 7	Axis pattern (m = 1) Absolute coordinate data	
		n + 8 -	Axis pattern (m = 2) Absolute coordinate data	
	:			
Traverse by relative command For orthogonal	1 - 8 (PLC1 - 8)	n	Station number	6 + 2m
		n + 1	Command: 235 (HEX)	
		n + 2	Axis pattern: m (number of ON bits)	
			Bit 	
		n + 3	Acceleration	
		n + 4	Deceleration	
		n + 5	Speed	
		n + 6 to n + 7	Axis pattern (m = 1) Relative coordinate data	
		n + 8 -	Axis pattern (m = 2) Relative coordinate data	
	:			
Jog/inching traverse	1 - 8 (PLC1 - 8)	n	Station number	9
		n + 1	Command: 236 (HEX)	
		n + 2	Axis pattern m	
			Bit 	
		n + 3	Acceleration	
		n + 4	Deceleration	
		n + 5	Speed	
		n + 6 to n + 7	Inching distance (absolute command) 0: Distance not designated = jog	
n + 8	Direction 0: Negative direction 1: Positive direction			
Traverse by point number command For orthogonal	1 - 8 (PLC1 - 8)	n	Station number	7
		n + 1	Command: 237 (HEX)	
		n + 2	Axis pattern	
			Bit 	
		n + 3	Acceleration	
		n + 4	Deceleration	
		n + 5	Speed	
n + 6	Point number			
Operation stop and cancel	1 - 8 (PLC1 - 8)	n	Station number	4
		n + 1	Command: 238 (HEX)	
		n + 2	Stop axis pattern	
			Bit 	
n + 3	Additional command			

Contents	F0	F1 (= \$u n)		F2		
Successive writing within designated point data range	1 - 8 (PLC1 - 8)	n	Station number	4 + (4 + 2m) t = α		
		n + 1	Command: 244 (HEX)			
		n + 2	Change start point data number			
		n + 3	Change point data count: t (1 to 2)			
		n + 4	Point data		Axis pattern: m (number of ON bits)	
					Bit	
		n + 5	t = 1		Acceleration	
		n + 6			Deceleration	
		n + 7			Speed	
		n + 8 to n + 9			Axis pattern (m = 1)	Position data
					Axis pattern (m = 2)	Position data
		n + 10 - α			:	:
					Point data (t = 2)	:
		α + 1			Change start point data number	
α + 2		Change complete point data count				
Change point data successive writing	1 - 8 (PLC1 - 8)	n	Station number	4 + (4 + 2m) t = α		
		n + 1	Command: 245 (HEX)			
		n + 2	Change point data count: t (1 to 2)			
		n + 3	Change point data number			
		n + 4	Point data		Axis pattern: m (number of ON bits)	
					Bit	
		n + 5	t = 1		Acceleration	
		n + 6			Deceleration	
		n + 7			Speed	
		n + 8 to n + 9			Axis pattern (m = 1)	Position data
					Axis pattern (m = 2)	Position data
		n + 10 to α			:	:
					Point data (t = 2)	:
		α + 1			Change complete point data count	
Point data clear	1 - 8 (PLC1 - 8)	n	Station number	4		
		n + 1	Command: 246 (HEX)			
		n + 2	Clear start point data number			
		n + 3	Clear point data count			
Real variable change	1 - 8 (PLC1 - 8)	n	Station number	5 + 2m		
		n + 1	Command: 24D (HEX)			
		n + 2	Program number			
		n + 3	Change start variable number			
		n + 4	Change variable data count: m (1 to 10)			
		n + 5 to n + 6			Variable data (m = 1)	Real variable data
					Variable data (m = 2)	Real variable data
		n + 7 -			:	
n + {5 + (2*m)}		Change complete data count				
Alarm reset	1 - 8 (PLC1 - 8)	n	Station number	2		
		n + 1	Command: 252 (HEX)			
Program execution	1 - 8 (PLC1 - 8)	n	Station number	3		
		n + 1	Command: 253 (HEX)			
		n + 2	Program number			
Program end	1 - 8 (PLC1 - 8)	n	Station number	3		
		n + 1	Command: 254 (HEX)			
		n + 2	Program number			

Contents	F0	F1 (= \$u n)		F2									
Program pause	1 - 8 (PLC1 - 8)	n	Station number	3									
		n + 1	Command: 255 (HEX)										
		n + 2	Program number										
Program one step execution	1 - 8 (PLC1 - 8)	n	Station number	3									
		n + 1	Command: 256 (HEX)										
		n + 2	Program number										
Program execution restart	1 - 8 (PLC1 - 8)	n	Station number	3									
		n + 1	Command: 257 (HEX)										
		n + 2	Program number										
Software reset	1 - 8 (PLC1 - 8)	n	Station number	2									
		n + 1	Command: 25B (HEX)										
Request for drive source recovery	1 - 8 (PLC1 - 8)	n	Station number	2									
		n + 1	Command: 25C (HEX)										
Request for operation pause cancel	1 - 8 (PLC1 - 8)	n	Station number	2									
		n + 1	Command: 25E (HEX)										
Speed change For orthogonal	1 - 8 (PLC1 - 8)	n	Station number	4									
		n + 1	Command: 262 (HEX)										
		n + 2	Axis pattern Bit <table border="1" style="display: inline-table; vertical-align: middle;"><tr><td>-</td><td>7</td><td>6</td><td>5</td><td>4</td><td>3</td><td>2</td><td>1</td><td>0</td></tr></table> └─ Axis 1 └─ Axis 6		-	7	6	5	4	3	2	1	0
		-	7		6	5	4	3	2	1	0		
n + 3	Speed												
Successive inquiry within designated range for coordinate system definition data For scalar	1 - 8 (PLC1 - 8)	n	Station number	5									
		n + 1	Command: 2A0 (HEX)										
		n + 2	Type 0: Workpiece coordinate system definition data 1: Tool coordinate system definition data										
		n + 3	Inquiry target top number for coordinate system definition data										
		n + 4	Inquiry record count t (1 to 32)										
		n + 5 to n + 6	Coordinate system definition data t = 1		Coordinate offset X axis								
		n + 7 to n + 8			Coordinate offset Y axis								
		n + 9 to n + 10			Coordinate offset Z axis								
		n + 11 to n + 12			Coordinate offset R axis								
		n + 13 -	Coordinate system definition data t = 2		:								
		Scalar axis status inquiry For scalar	1 - 8 (PLC1 - 8)		n	Station number	4						
n + 1	Command: 2A1 (HEX)												
n + 2	Inquiry axis pattern: m (number of ON bits) Bit <table border="1" style="display: inline-table; vertical-align: middle;"><tr><td>-</td><td>7</td><td>6</td><td>5</td><td>4</td><td>3</td><td>2</td><td>1</td><td>0</td></tr></table> └─ Axis 1 └─ Axis 6			-	7	6		5	4	3	2	1	0
-	7			6	5	4		3	2	1	0		
n + 3	Type 0: Base coordinate system 1: Selected workpiece coordinate system 2: System reserved 3: Coordinate system for each axis												
n + 4	Workpiece coordinate system number												
n + 5	Tool coordinate system number												
n + 6	Axis common status												
n + 7	Axis status												
n + 8	Axis pattern m = 1			Axis sensor input status									
n + 9				Axis-related error code									
n + 10				Encoder status									
n + 11 to n + 12				Current position									
n + 13 -	Axis pattern (m = 2)	:											

Contents	F0	F1 (= \$u n)		F2											
Successive inquiry within designated range for interference check zone definition data For scalar	1 - 8 (PLC1 - 8)	n	Station number		4										
		n + 1	Command: 2A2 (HEX)												
		n + 2	Inquiry top number for interference check zone definition data												
		n + 3	Inquiry record count t (1 to 16)												
		n + 4	Interference check zone definition data t = 1	Effective axis pattern: m (number of ON bits) Bit <table border="1" style="display: inline-table; vertical-align: middle;"><tr><td>-</td><td>7</td><td>6</td><td>5</td><td>4</td><td>3</td><td>2</td><td>1</td><td>0</td></tr></table> └─ Axis 1 └─ Axis 6		-	7	6	5	4	3	2	1	0	
		-		7		6	5	4	3	2	1	0			
		n + 5 to n + 6		Axis pattern (m = 1)		Interference check zone definition coordinate 1									
		n + 7 -		Axis pattern (m = 2)		Interference check zone definition coordinate 1									
		:		:		:									
		n + (5 + 2m)		Axis pattern (m = 1)		Interference check zone definition coordinate 2									
		:		Axis pattern (m = 2)		Interference check zone definition coordinate 2									
		:		:		:									
		n + (5 + 4m)		Physical output port number at break-in or global flag number											
		n + (6 + 4m)		Error type definition at break-in											
n + (7 + 4m)	System reserved														
:	Interference check data t = 2														
:	:														
Traverse by absolute command For scalar	1 - 8 (PLC1 - 8)	n	Station number		7 + 2m										
		n + 1	Command: 2D4 (HEX)												
		n + 2	Axis pattern: m (number of ON bits) Bit <table border="1" style="display: inline-table; vertical-align: middle;"><tr><td>-</td><td>7</td><td>6</td><td>5</td><td>4</td><td>3</td><td>2</td><td>1</td><td>0</td></tr></table> └─ Axis 1 └─ Axis 6			-	7	6	5	4	3	2	1	0	
		-	7	6		5	4	3	2	1	0				
		n + 3	Acceleration												
		n + 4	Deceleration												
		n + 5	Speed												
		n + 6	Positioning type												
		n + 7 to n + 8	Axis pattern (m = 1)	Absolute coordinate data											
		n + 9 to n + 10	Axis pattern (m = 2)	Absolute coordinate data											
:	:														
Traverse by relative command For scalar	1 - 8 (PLC1 - 8)	n	Station number		7 + 2m										
		n + 1	Command: 2D5 (HEX)												
		n + 2	Inquiry axis pattern: m (number of ON bits) Bit <table border="1" style="display: inline-table; vertical-align: middle;"><tr><td>-</td><td>7</td><td>6</td><td>5</td><td>4</td><td>3</td><td>2</td><td>1</td><td>0</td></tr></table> └─ Axis 1 └─ Axis 6			-	7	6	5	4	3	2	1	0	
		-	7	6		5	4	3	2	1	0				
		n + 3	Acceleration												
		n + 4	Deceleration												
		n + 5	Speed												
		n + 6	Positioning type												
		n + 7 to n + 8	Axis pattern (m = 1)	Relative coordinate data											
		n + 9 to n + 10	Axis pattern (m = 2)	Relative coordinate data											
:	:														

Contents	F0	F1 (= \$u n)		F2									
Traverse by point number command For scalar	1 - 8 (PLC1 - 8)	n	Station number	8									
		n + 1	Command: 2D6 (HEX)										
		n + 2	Inquiry axis pattern: m (number of ON bits) Bit <table border="1" style="display: inline-table; vertical-align: middle;"> <tr> <td>-</td> <td>7</td> <td>6</td> <td>5</td> <td>4</td> <td>3</td> <td>2</td> <td>1</td> <td>0</td> </tr> </table> 		-	7	6	5	4	3	2	1	0
		-	7		6	5	4	3	2	1	0		
		n + 3	Acceleration										
		n + 4	Deceleration										
		n + 5	Speed										
		n + 6	Positioning type										
n + 7 to n + 8	Point number												

Return data: Data stored from controller to V series

2.1.2 ROBO CYLINDER (RCP2/ERC)

Communication Setting

Editor

Communication setting

(Underlined setting: default)

Item	Setting	Remarks
Connection Mode	1 : 1 / <u>1:n</u> / Multi-link2 / Multi-link2 (Ethernet) / 1 : n multi-link2 (Ethernet)	
Signal Level	<u>RS-232C</u> / RS-422/485	
Baud Rate	9600 / 19200 / <u>38400</u> / 115K bps	
Data Length	8 bits	
Stop Bit	1 bit	
Parity	None	
Target Port No.	0 to 15	

ROBO CYLINDER

RCP2

Application software

Set parameters using the application software.

(Underlined setting: default)

Parameter No.	Parameter Name	Setting
Parameter 16	SIO baud rate	9600 / 19200 / <u>38400</u> / 115200 bps

Axis number setting switch (ADRS)

ADRS	Setting	Remarks
	0 to F (0 to 15)	

After changing the setting, be sure to turn the power off and back on again.

PORT switch (PORT)

PORT	Setting	Remarks
PORT  ON OFF	ON	

Emergency stop terminal block

When the servo cannot be turned on, check the wiring of the emergency stop terminal block.

- RCP2-C / RCP2-CF (with built-in cutout relay)**
 Connect the EMG switch between the S1 terminal and the 24-V terminal.
 When the EMG switch is not used, short-circuit them.
 Short-circuit the terminals S2 and EMG, and MPI and MPO, respectively.
- RCP2-CG (with external cutout relay)**
 Install wiring by referring to the specifications sheet of RCP2.

ERC**Application software**

Set parameters using the application software.

(Underlined setting: default)

Parameter No.	Parameter Name	Setting
Parameter 16	Serial communication speed	9600 / 19200 / <u>38400</u> / 115200 bps

Item	Parameter Name	Setting
Axis number assignment	Axis number table	0 to 15

RCB-TU-SIO-A/B**PORT switch (PORT)**

PORT	Setting	Remarks
 SW1	ON	

Emergency stop terminal block

When the servo cannot be turned on, connect the EMG switch between the EMG1 terminal and the EMG2 terminal on the emergency stop terminal block.

When the EMG switch is not used, short-circuit them.

Available Device Memory

The available setting range of device memory varies depending on the model. Be sure to set within the range available for the model to be used. Use [TYPE] when assigning indirect device memory for macro programs.

Device Memory	TYPE	Remarks
SW (status)	00H	Read only
PD (positioning data)	01H	Double-word, write only
CW (control data)	02H	Write only
4D (window area)	03H	Double-word
MD (window area (in mm))	04H	Double-word

PLC_CTL

Contents	F0	F1 (= \$u n)	F2
Non-volatile memory area ↓ Transfer to window area	1 - 8 (PLC1 - 8)	n	Station number
		n + 1	Command: 51 (HEX)
		n + 2	Position number RCP2: 0 to 63 ERC: 0 to 7
Window area ↓ Transfer to non-volatile memory area	1 - 8 (PLC1 - 8)	n	Station number
		n + 1	Command: 56 (HEX)
		n + 2	Position number RCP2: 0 to 63 ERC: 0 to 7
		n + 3 to n + 4	Total number of writing times
Remaining amount of movement cancel	1 - 8 (PLC1 - 8)	n	Station number
		n + 1	Command: 64 (HEX)

Contents	F0	F1 (= \$u n)		F2
Speed, acceleration setting (in mm)	1 - 8 (PLC1 - 8)	n	Station number	4
		n + 1	Command: 66 (HEX)	
		n + 2	Speed	
		n + 3	Acceleration	
Speed, acceleration setting	1 - 8 (PLC1 - 8)	n	Station number	4
		n + 1	Command: 76 (HEX)	
		n + 2	Speed	
		n + 3	Acceleration	
Deceleration stop	1 - 8 (PLC1 - 8)	n	Station number	2
		n + 1	Command: 6B (HEX)	
Alarm reset	1 - 8 (PLC1 - 8)	n	Station number	2
		n + 1	Command: 72 (HEX)	

 Return data: Data stored from controller to V series

2.1.3 ROBO CYLINDER (RCS/E-CON)

Communication Setting

Editor

Communication setting

(Underlined setting: default)

Item	Setting	Remarks
Connection Mode	1 : 1 / <u>1 : n</u> / Multi-link2 / Multi-link2 (Ethernet) / 1 : n Multi-link2 (Ethernet)	
Signal Level	<u>RS-232C</u> / RS-422/485	
Baud Rate	9600 / 19200 / <u>38400</u> / 57600 / 115K bps	
Data Length	8 bits	
Stop Bit	1 bit	
Parity	None	
Target Port No.	0 to 15	

ROBO CYLINDER

RCS

Application software

Set parameters using the application software.

(Underlined setting: default)

Parameter No.	Parameter Name	Setting
Parameter 16	SIO baud rate	9600 / 19200 / <u>38400</u> / 58600 / 115200 bps

RCS axis number setting switch

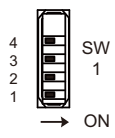
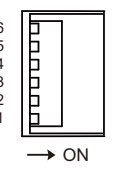
SW	Setting	Remarks																																																																																										
RCS-C: SW1  RCS-E: SW (switch No. 1 to 4) 	<table border="1"> <thead> <tr> <th>Axis number</th> <th colspan="4">Switch number</th> </tr> <tr> <th></th> <th>1</th> <th>2</th> <th>3</th> <th>4</th> </tr> </thead> <tbody> <tr> <td>0</td> <td>OFF</td> <td>OFF</td> <td>OFF</td> <td>OFF</td> </tr> <tr> <td>1</td> <td>ON</td> <td>OFF</td> <td>OFF</td> <td>OFF</td> </tr> <tr> <td>2</td> <td>OFF</td> <td>ON</td> <td>OFF</td> <td>OFF</td> </tr> <tr> <td>3</td> <td>ON</td> <td>ON</td> <td>OFF</td> <td>OFF</td> </tr> <tr> <td>4</td> <td>OFF</td> <td>OFF</td> <td>ON</td> <td>OFF</td> </tr> <tr> <td>5</td> <td>ON</td> <td>OFF</td> <td>ON</td> <td>OFF</td> </tr> <tr> <td>6</td> <td>OFF</td> <td>ON</td> <td>ON</td> <td>OFF</td> </tr> <tr> <td>7</td> <td>ON</td> <td>ON</td> <td>ON</td> <td>OFF</td> </tr> <tr> <td>8</td> <td>OFF</td> <td>OFF</td> <td>OFF</td> <td>ON</td> </tr> <tr> <td>9</td> <td>ON</td> <td>OFF</td> <td>OFF</td> <td>ON</td> </tr> <tr> <td>10</td> <td>OFF</td> <td>ON</td> <td>OFF</td> <td>ON</td> </tr> <tr> <td>11</td> <td>ON</td> <td>ON</td> <td>OFF</td> <td>ON</td> </tr> <tr> <td>12</td> <td>OFF</td> <td>OFF</td> <td>ON</td> <td>ON</td> </tr> <tr> <td>13</td> <td>ON</td> <td>OFF</td> <td>ON</td> <td>ON</td> </tr> <tr> <td>14</td> <td>OFF</td> <td>ON</td> <td>ON</td> <td>ON</td> </tr> <tr> <td>15</td> <td>ON</td> <td>ON</td> <td>ON</td> <td>ON</td> </tr> </tbody> </table>	Axis number	Switch number					1	2	3	4	0	OFF	OFF	OFF	OFF	1	ON	OFF	OFF	OFF	2	OFF	ON	OFF	OFF	3	ON	ON	OFF	OFF	4	OFF	OFF	ON	OFF	5	ON	OFF	ON	OFF	6	OFF	ON	ON	OFF	7	ON	ON	ON	OFF	8	OFF	OFF	OFF	ON	9	ON	OFF	OFF	ON	10	OFF	ON	OFF	ON	11	ON	ON	OFF	ON	12	OFF	OFF	ON	ON	13	ON	OFF	ON	ON	14	OFF	ON	ON	ON	15	ON	ON	ON	ON	Always turn the switches 5 and 6 of RCS-E.
	Axis number	Switch number																																																																																										
		1	2	3	4																																																																																							
	0	OFF	OFF	OFF	OFF																																																																																							
	1	ON	OFF	OFF	OFF																																																																																							
	2	OFF	ON	OFF	OFF																																																																																							
	3	ON	ON	OFF	OFF																																																																																							
	4	OFF	OFF	ON	OFF																																																																																							
	5	ON	OFF	ON	OFF																																																																																							
	6	OFF	ON	ON	OFF																																																																																							
	7	ON	ON	ON	OFF																																																																																							
	8	OFF	OFF	OFF	ON																																																																																							
	9	ON	OFF	OFF	ON																																																																																							
	10	OFF	ON	OFF	ON																																																																																							
	11	ON	ON	OFF	ON																																																																																							
12	OFF	OFF	ON	ON																																																																																								
13	ON	OFF	ON	ON																																																																																								
14	OFF	ON	ON	ON																																																																																								
15	ON	ON	ON	ON																																																																																								

When changing the switch setting, turn the power off.

PORT switch (PORT)

PORT	Setting	Remarks
	ON	

Emergency stop terminal block

When the servo cannot be turned on, connect the EMG switch between the EMG1 terminal and the EMG2 terminal on the emergency stop terminal block.

When the EMG switch is not used, short-circuit them.

E-CON

Application software

Set parameters using the application software.

(Underlined setting: default)

Parameter No.	Parameter Name	Setting
Parameter 16	Serial communication speed	9600 / 19200 / <u>38400</u> / 115200 bps

RCS axis number setting switch

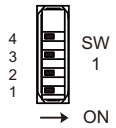
SW1	Axis number	Setting				Remarks
		1	2	3	4	
	<u>0</u>	OFF	OFF	OFF	OFF	
	1	ON	OFF	OFF	OFF	
	2	OFF	ON	OFF	OFF	
	3	ON	ON	OFF	OFF	
	4	OFF	OFF	ON	OFF	
	5	ON	OFF	ON	OFF	
	6	OFF	ON	ON	OFF	
	7	ON	ON	ON	OFF	
	8	OFF	OFF	OFF	ON	
	9	ON	OFF	OFF	ON	
	10	OFF	ON	OFF	ON	
	11	ON	ON	OFF	ON	
	12	OFF	OFF	ON	ON	
	13	ON	OFF	ON	ON	
	14	OFF	ON	ON	ON	
15	ON	ON	ON	ON		

When changing the switch setting, turn the power off.

PORT switch (PORT)

PORT	Setting	Remarks
	ON	

Emergency stop terminal block

When the servo cannot be turned on, connect the EMG switch between the EMG1 terminal and the EMG2 terminal on the emergency stop terminal block.

When the EMG switch is not used, short-circuit them.

RCB-TU-SIO-A/B

PORT switch (PORT)

PORT	Setting	Remarks
	ON	

Emergency stop terminal block

When the servo cannot be turned on, connect the EMG switch between the EMG1 terminal and the EMG2 terminal on the emergency stop terminal block.

When the EMG switch is not used, short-circuit them.

Available Device Memory

The available setting range of device memory varies depending on the model. Be sure to set within the range available for the model to be used. Use [TYPE] when assigning indirect device memory for macro programs.

Device Memory	TYPE	Remarks
SW (status)	00H	Read only
PD (positioning data)	01H	Double-word, write only
CW (control data)	02H	Write only
4D (window area)	03H	Double-word
MD (window area (in mm))	04H	Double-word

PLC_CTL

Contents	F0	F1 (= \$u n)	F2
Non-volatile memory area ↓ Transfer to window area	1 - 8 (PLC1 - 8)	n	Station number
		n + 1	Command: 51 (HEX)
		n + 2	Position number RCP2: 0 to 15 E-CON: 0 to 63
Window area ↓ Transfer to non-volatile memory area	1 - 8 (PLC1 - 8)	n	Station number
		n + 1	Command: 56 (HEX)
		n + 2	Position number
		n + 3 to n + 4	Total number of writing times
Remaining amount of movement cancel	1 - 8 (PLC1 - 8)	n	Station number
		n + 1	Command: 64 (HEX)
Speed, acceleration setting (in mm)	1 - 8 (PLC1 - 8)	n	Station number
		n + 1	Command: 66 (HEX)
		n + 2	Speed
		n + 3	Acceleration
Speed, acceleration setting	1 - 8 (PLC1 - 8)	n	Station number
		n + 1	Command: 76 (HEX)
		n + 2	Speed
		n + 3	Acceleration
Deceleration stop	1 - 8 (PLC1 - 8)	n	Station number
		n + 1	Command: 6B (HEX)
Alarm reset	1 - 8 (PLC1 - 8)	n	Station number
		n + 1	Command: 72 (HEX)

 Return data: Data stored from controller to V series

2.1.4 PCON / ACON / SCON (MODBUS RTU)

Communication Setting

Editor

Communication setting

(Underlined setting: default)

Item	Setting	Remarks
Connection Mode	1 : 1 / <u>1 : n</u> / Multi-link2 / Multi-link2 (Ethernet) / 1 : n Multi-link2 (Ethernet)	
Signal Level	RS-232C / RS-422/485	
Baud Rate	9600 / 19200 / <u>38400</u> / 57600 / 115K bps	
Data Length	8 bits	
Stop Bit	1 bit	
Parity	None	
Target Port No.	0 to 15	Set the same number as the IAI axis number.

PCON / ACON / SCON

Exclusive software

Set parameters using the exclusive software.

(Underlined setting: default)

Parameter No.	Parameter Name	Setting
Parameter 16	SIO baud rate	9600 / 19200 / <u>38400</u> / 115200 bps

Axis number setting switch (ADRS)

ADRS	Setting	Remarks
	0 to F (0 to 15)	

After changing the setting, be sure to turn the power off and back on again.

Mode select switch

Select [MANU].

Emergency stop terminal block

When the servo cannot be turned on, check the emergency stop terminal block.

- ACON-C, PCON-C/CF (with built-in cutout relay)**
 Connect the EMG switch between the S1 terminal and the 24-V terminal.
 When the EMG switch is not used, short-circuit them.
 Short-circuit the terminals S2 and EMG-, and MPI and MPO, respectively.
- ACON-CY/PL/PO/SE, PCON-CY/PL/PO/SE (with built-in cutout relay)**
 Connect the EMG switch between the EMG- terminal and the 24-V terminal.
 When the EMG switch is not used, short-circuit them.
 Short-circuit the MPI terminal and the MPO terminal.
- ACON-CG / PCON-CG (with external cutout relay)**
 Install wiring by referring to the specifications sheet of ACON/PCON.
- SCON**
 Connect the EMG switch between the S1 terminal and the EMG- terminal.
 When the EMG switch is not used, short-circuit them.
 Short-circuit the S2 terminal and the EMG+ terminal.

RCB-TU-SIO-A/B**PORT switch (PORT)**

PORT	Setting	Remarks
 SW1	ON	

Emergency stop terminal block

When the servo cannot be turned on, connect the EMG switch between the EMG1 terminal and the EMG2 terminal on the emergency stop terminal block.

When the EMG switch is not used, short-circuit them.

Available Device Memory

The available setting range of device memory varies depending on the model. Be sure to set within the range available for the model to be used. Use [TYPE] when assigning indirect device memory for macro programs.

Device Memory	TYPE	Remarks
Coil (coil)	00H	
Register (holding register)	02H	

2.1.5 Wiring Diagrams

When Connected at CN1:

RS-232C

Wiring diagram 1 - C2

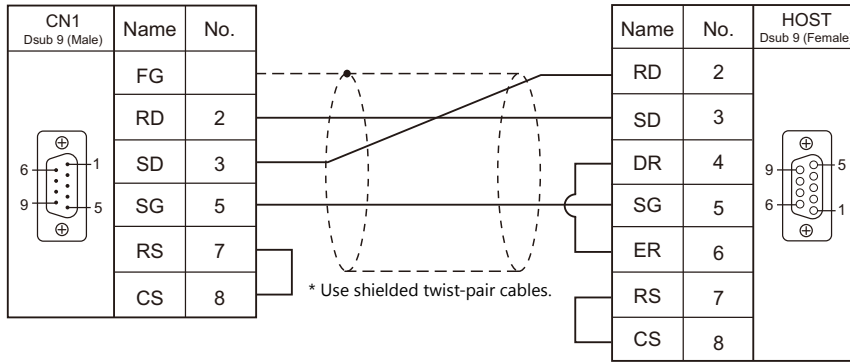

Wiring diagram 2 - C2

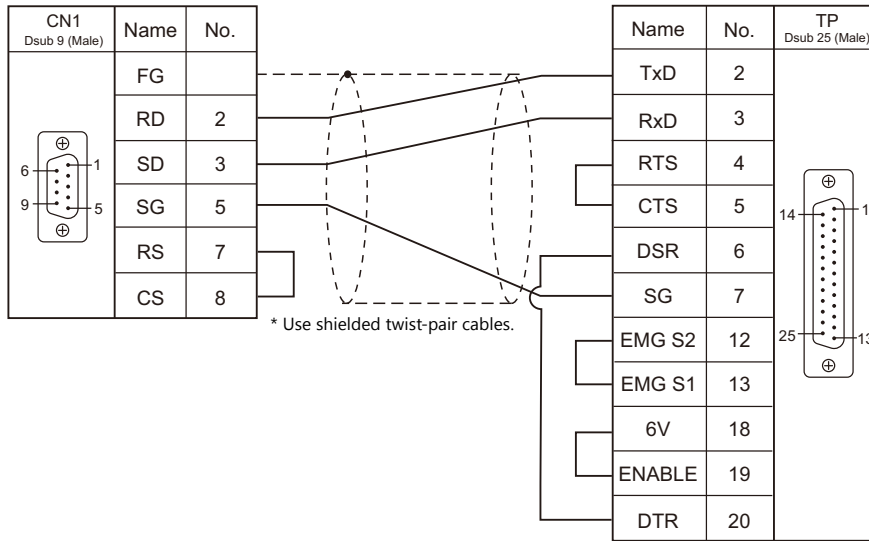

Wiring diagram 3 - C2

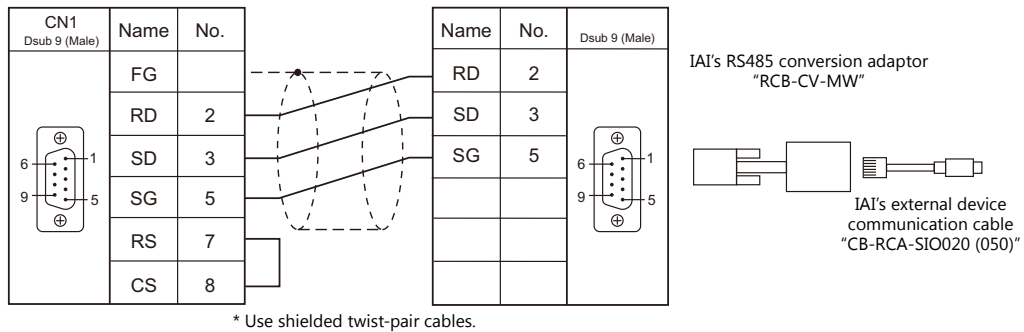

Wiring diagram 4 - C2

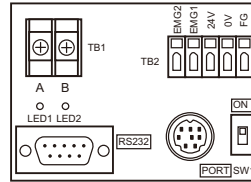
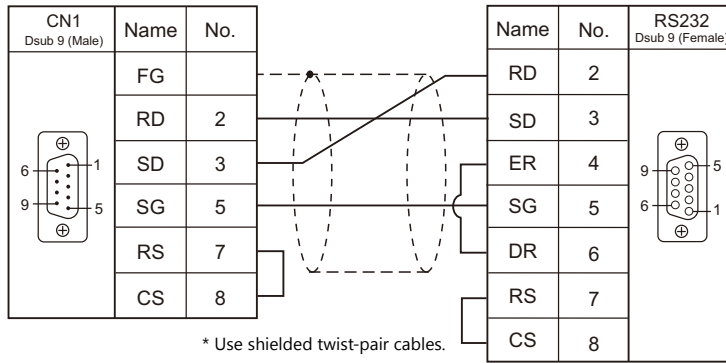

IAI's SIO converter "RCB-TU-SIO-A/B"

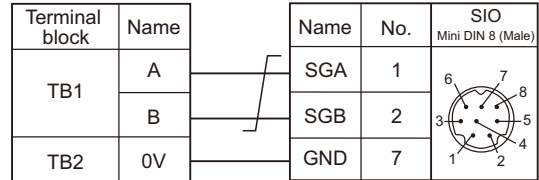

RS-485

Wiring diagram 1 - C4

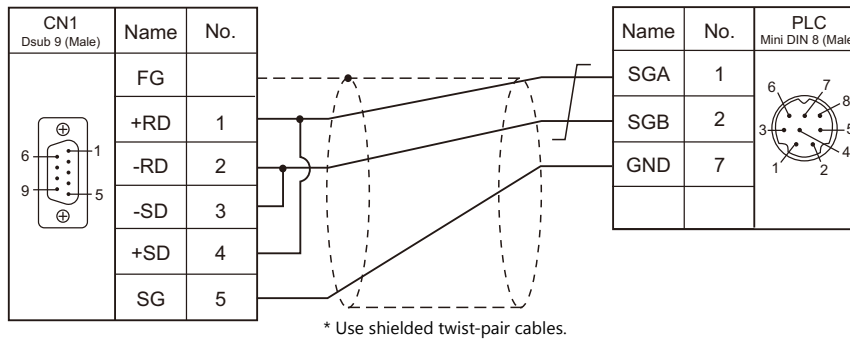

When Connected at MJ1/MJ2:

RS-232C

Wiring diagram 1 - M2

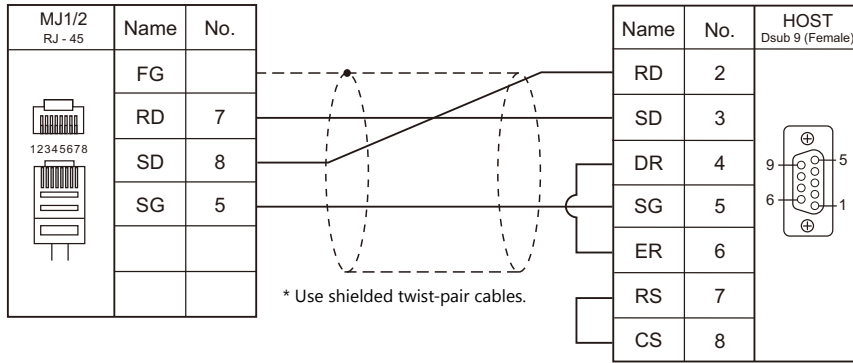

Wiring diagram 2 - M2

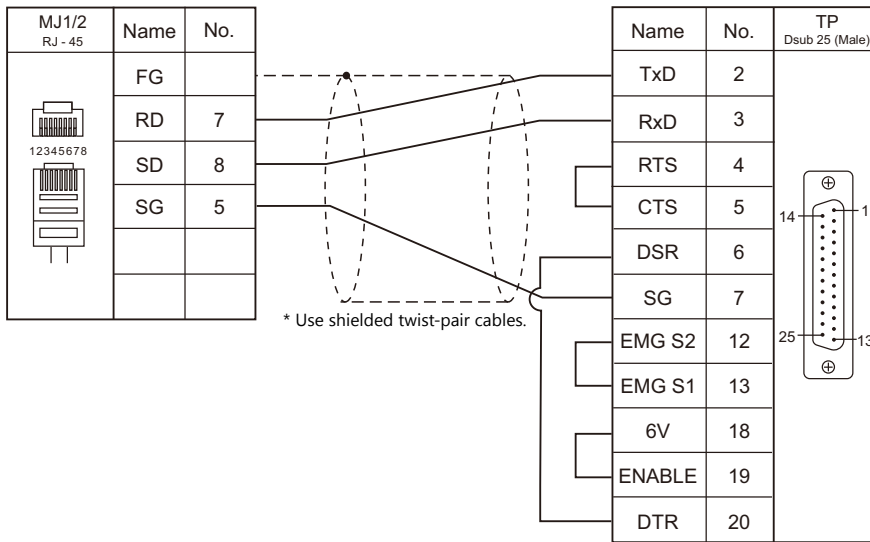

Wiring diagram 3 - M2

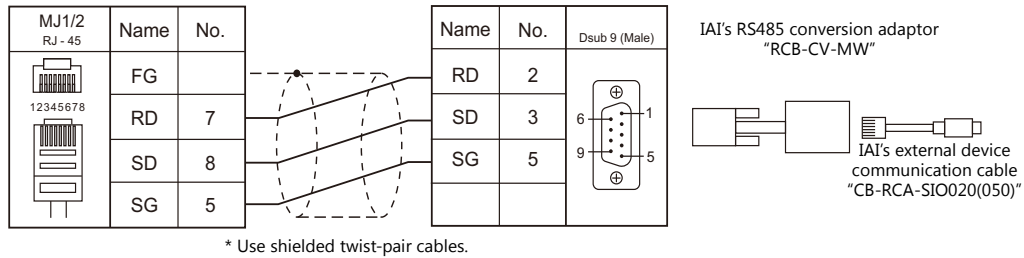

Wiring diagram 4 - M2

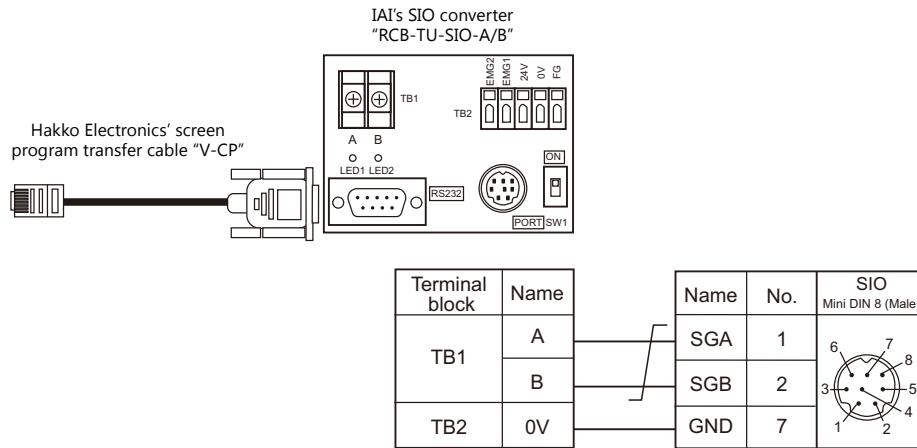

RS-485

Wiring diagram 1 - M4

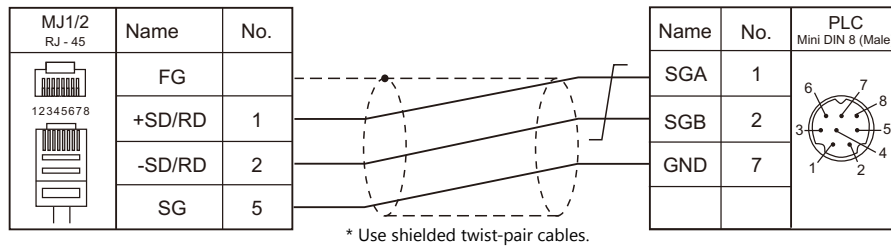

MEMO

Please use this page freely.

3. IDEC

3.1 PLC Connection

3.1 PLC Connection

Serial Connection

PLC Selection on the Editor	CPU	Unit/Port		Signal Level	Connection		Ladder Transfer ^{*1}			
					CN1	MJ1/MJ2				
MICRO 3	FC2A-Cxxxx	Loader port		RS-232C	IDEC's cable "FC2A-KC1" +Wiring diagram 1 - C2 or IDEC's cable "FC2A-KC2" +Wiring diagram 2 - C2	IDEC's cable "FC2A-KC1" +Wiring diagram 1 - M2 or IDEC's cable "FC2A-KC2" +Wiring diagram 2 - M2				
					FC2A-LC1	RS-485		Wiring diagram 1 - C4	Wiring diagram 1 - M4	
MICRO Smart	FC4A-Cxxxxx FC4A-Dxxxxx ^{*2 *3}	Port 1	CPU (built-in)	RS-232C	Wiring diagram 3 - C2 or IDEC's cable "FC4A-KC1C" +Wiring diagram 4 - C2 or IDEC's cable "FC4A-KC2C" +Wiring diagram 5 - C2	Wiring diagram 3 - M2 or IDEC's cable "FC4A-KC1C" +Wiring diagram 4 - M2 or IDEC's cable "FC4A-KC2C" +Wiring diagram 5 - M2	×			
					Port 2	FC4A-PC1 FC4A-HPC1		RS-232C	Wiring diagram 6 - C2 or IDEC's cable "FC4A-KC1C" +Wiring diagram 4 - C2 or IDEC's cable "FC4A-KC2C" +Wiring diagram 5 - C2	Wiring diagram 6 - M2 or IDEC's cable "FC4A-KC1C" +Wiring diagram 4 - M2 or IDEC's cable "FC4A-KC2C" +Wiring diagram 5 - M2
			FC4A-PC2 FC4A-HPC2	RS-485					Wiring diagram 2 - C4	Wiring diagram 2 - M4
			FC4A-PC3 FC4A-HPC3	RS-485	Wiring diagram 1 - C4	Wiring diagram 1 - M4				
MICRO Smart pentra	FC5A-Cxxxxx FC5A-Dxxxxx	Port 1	CPU (built-in)	RS-232C	Wiring diagram 3 - C2 or IDEC's cable "FC4A-KC1C" +Wiring diagram 4 - C2 or IDEC's cable "FC4A-KC2C" +Wiring diagram 5 - C2	Wiring diagram 3 - M2 or IDEC's cable "FC4A-KC1C" +Wiring diagram 4 - M2 or IDEC's cable "FC4A-KC2C" +Wiring diagram 5 - M2				
					Port 2	FC4A-PC1 FC4A-HPC1		RS-232C	Wiring diagram 6 - C2 or IDEC's cable "FC4A-KC1C" +Wiring diagram 4 - C2 or IDEC's cable "FC4A-KC2C" +Wiring diagram 5 - C2	Wiring diagram 6 - M2 or IDEC's cable "FC4A-KC1C" +Wiring diagram 4 - M2 or IDEC's cable "FC4A-KC2C" +Wiring diagram 5 - M2
			FC4A-PC2 FC4A-HPC2	RS-485					Wiring diagram 2 - C4	Wiring diagram 2 - M4
			FC4A-PC3 FC4A-HPC3	RS-485					Wiring diagram 1 - C4	Wiring diagram 1 - M4
		Port 3 to 7		FC5A-SIF2 ^{*4}	RS-232C	Wiring diagram 7 - C2		Wiring diagram 7 - M2		
				FC5A-SIF4 ^{*4}	RS-485	Wiring diagram 1 - C4		Wiring diagram 1 - M4		

*1 For the ladder transfer function, see the V9 Series Reference Manual.

*2 With "FC4A-C10Rxx", only port 1 can be used.

*3 When the communication board "FC4A-PCx" is used with "FX4A-Dxxxx", IDEC's HMI base module "FC4A-HPH1" is necessary.

*4 "FC5A-C10Rxx" and "FC5A0C16Rxx" cannot be used.

A maximum of 3 units of "FC5A-C24Rxx" or 5 units of "FC5A-Dxxxx" can be added.

3.1.1 MICRO 3

Communication Setting

Editor

Communication setting

(Underlined setting: default)

Item	Setting	Remarks
Connection Mode	<u>1</u> :1 / 1 : n / Multi-link2 / Multi-link2 (Ethernet) / 1 : n Multi-link2 (Ethernet)	
Signal Level	<u>RS-232C</u> / RS-422/485	
Baud Rate	4800 / <u>9600</u> / 19200 bps	
Data Length	<u>7</u> / 8 bits	
Stop Bit	<u>1</u> / 2 bits	
Parity	None / Odd / <u>Even</u>	
Target Port No.	<u>0</u> to 31	

PLC

Function setting (communication)

(Underlined setting: default)

Item	Setting	Remarks
Communication Device No. Setting	0	
Loader Port Communication Mode	Arbitrary setting mode	
Communication Condition Selection Input No.	X0000	
Baud Rate	4800 / <u>9600</u> / 19200 bps	
Data Bit	<u>7</u> / 8 bits	
Parity	None / Odd / <u>Even</u>	
Stop Bit	<u>1</u> / 2 bits	
Terminator Code	CR	
Receive Timeout	Make settings in accordance with the network environment.	

Available Device Memory

The available setting range of device memory varies depending on the PLC model. Be sure to set within the range available for the PLC to be used. Use [TYPE] when assigning indirect device memory for macro programs.

Device Memory	TYPE	Remarks
D (data register)	00H	
I (input)	01H	*1
Q (output)	02H	*1
M (internal relay)	03H	*1
R (shift register)	04H	
TS (timer/set value)	05H	
TN (timer/enumerated value)	06H	
T (timer/contact)	07H	Read only
CS (counter/set value)	08H	
CN (counter/enumerated value)	09H	
C (counter/contact)	0AH	Read only

*1 The assigned device memory is expressed as shown on the right when editing the screen. The addresses are expressed in "bytes". For word designation, specify an even-numbered address.

Example: M2000

↑
Last one digit: 0 to 7 (octal)
Other digits: 0 to 9 (decimal)

3.1.2 MICRO Smart

Communication Setting

Editor

Communication setting

Item	Setting	Remarks
Connection Mode	<u>1</u> :1 / 1 : n / Multi-link2 / Multi-link2 (Ethernet) / 1 : n Multi-link2 (Ethernet)	
Signal Level	<u>RS-232C</u> / RS-422/485	
Baud Rate	4800 / <u>9600</u> / 19200 bps	
Data Length	<u>7</u> / 8 bits	
Stop Bit	<u>1</u> / 2 bits	
Parity	None / Odd / <u>Even</u>	
Target Port No.	<u>0</u> to 31	

PLC

Function setting (communication)

(Underlined setting: default)

Item	Setting	Remarks
Communication Type	Maintenance communication	
Baud Rate (bps)	4800 / <u>9600</u> / 19200 bps	
Data Bit Length	<u>7</u> / 8 bits	
Parity	None / Odd / <u>Even</u>	
Stop Bit Length	<u>1</u> / 2 bits	
Receive Timeout Time	Make settings in accordance with the network environment.	
Communication Device No.	0	
Communication Selection Input	X0000	

Available Device Memory

The available setting range of device memory varies depending on the PLC model. Be sure to set within the range available for the PLC to be used. Use [TYPE] when assigning indirect device memory for macro programs.

Device Memory	TYPE	Remarks
D (data register)	00H	
I (input)	01H	*1
Q (output)	02H	*1
M (internal relay)	03H	*1
R (shift register)	04H	
TS (timer/set value)	05H	
TN (timer/enumerated value)	06H	
T (timer/contact)	07H	Read only
CS (counter/set value)	08H	
CN (counter/enumerated value)	09H	
C (counter/contact)	0AH	Read only

*1 The assigned device memory is expressed as shown on the right when editing the screen. The addresses are expressed in "bytes". For word designation, specify an even-numbered address.

Example: M2000

↑ Last one digit: 0 to 7 (octal)
 └─ Other digits: 0 to 9 (decimal)

3.1.3 MICRO Smart Pentra

Communication Setting

Editor

Communication setting

Item	Setting	Remarks
Connection Mode	<u>1</u> -1 / 1 : n / Multi-link2 / Multi-link2 (Ethernet) / 1 : n Multi-link2 (Ethernet)	
Signal Level	<u>RS-232C</u> / RS-422/485	
Baud Rate	4800 / <u>9600</u> / 19200 / 38400 / 57600 / 115K bps	
Data Length	<u>7</u> / 8 bits	
Stop Bit	<u>1</u> / 2 bits	
Parity	None / Odd / <u>Even</u>	
Target Port No.	<u>0</u> to 31	
Transmission Mode	Little Endian / <u>Big Endian</u>	

PLC

Function setting (communication)

(Underlined setting: default)

Item	Setting	Remarks
Communication Type	Maintenance communication	
Baud Rate (bps)	4800 / <u>9600</u> / 19200 / 38400 / 57600 / 115K bps	For the add-on communication module "FC5A-SIF2", the maximum available rate is 38400 bps. 115 kbps is available only for the add-on communication module "FC5A-SIF4".
Data Bit Length	<u>7</u> / 8 bits	
Parity	None / Odd / <u>Even</u>	
Stop Bit Length	<u>1</u> / 2 bits	
Receive Timeout Time	Make settings in accordance with the network environment.	
Communication Device No.	0	
Communication Selection Input	X0000	

Function setting (other 2)

(Underlined setting: default)

Item	Setting	Remarks
32-bit Data Storage Setting	From lower word / <u>From higher word</u>	From lower word: little endian From higher word: big endian

Available Device Memory

The available setting range of device memory varies depending on the PLC model. Be sure to set within the range available for the PLC to be used. Use [TYPE] when assigning indirect device memory for macro programs.

Device Memory	TYPE	Remarks
D (data register)	00H	
I (input)	01H	*1
Q (output)	02H	*1
M (internal relay)	03H	*1
R (shift register)	04H	
TS (timer/set value)	05H	
TN (timer/enumerated value)	06H	
T (timer/contact)	07H	Read only
CS (counter/set value)	08H	
CN (counter/enumerated value)	09H	
C (counter/contact)	0AH	Read only

- *1 The assigned device memory is expressed as shown on the right when editing the screen.
The addresses are expressed in "bytes". For word designation, specify an even-numbered address.

Example: M2000

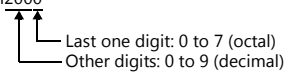

3.1.4 Wiring Diagrams

When Connected at CN1:

RS-232C

Wiring diagram 1 - C2

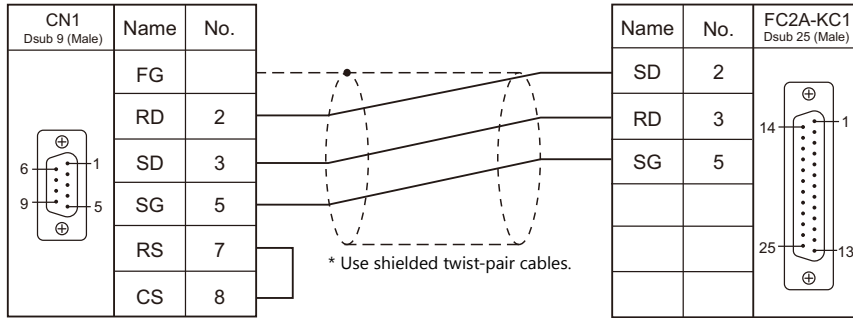

Wiring diagram 2 - C2

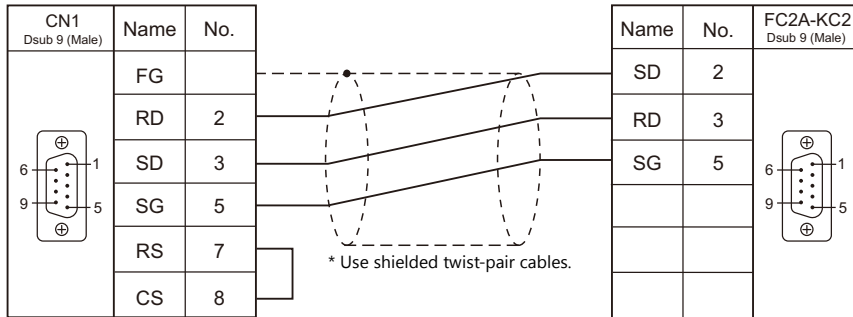

Wiring diagram 3 - C2

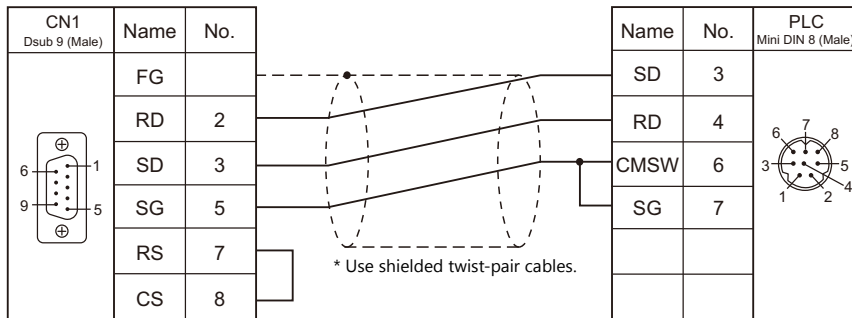

Wiring diagram 4 - C2

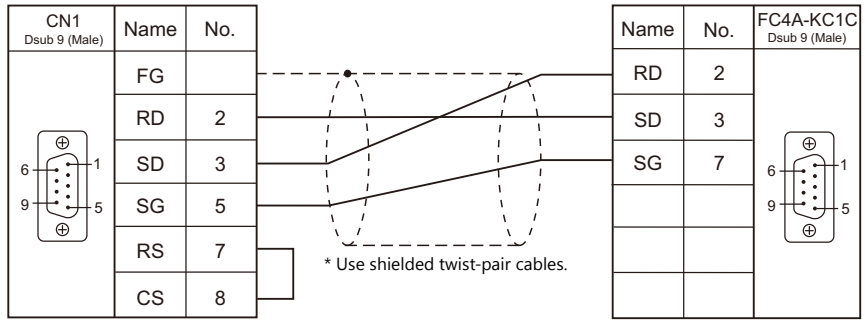

Wiring diagram 5 - C2

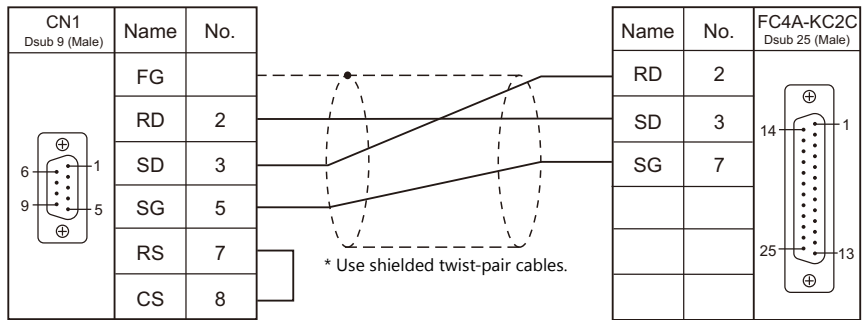

Wiring diagram 6 - C2

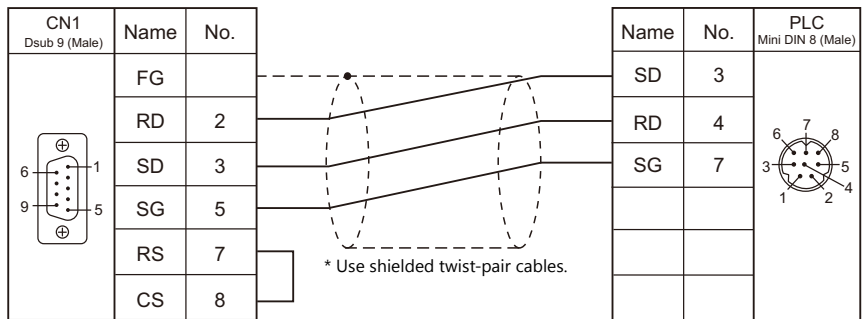

Wiring diagram 7 - C2

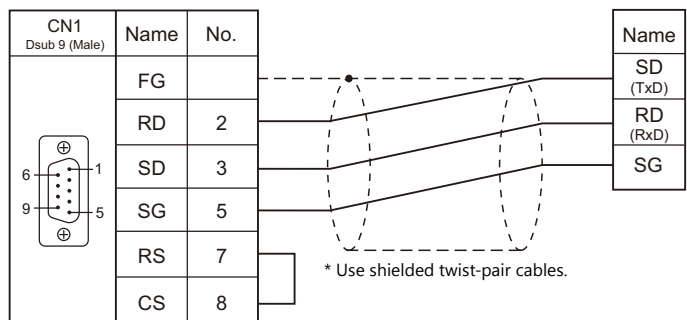

RS-422/RS-485

Wiring diagram 1 - C4

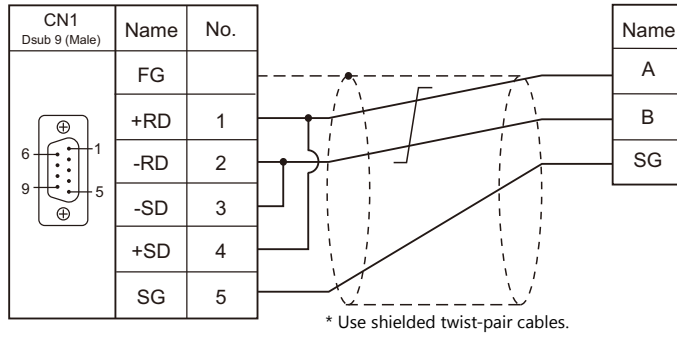

Wiring diagram 2 - C4

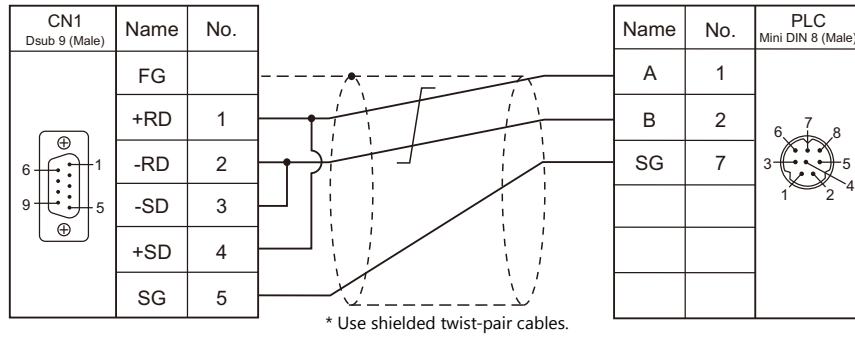

When Connected at MJ1/MJ2:

RS-232C

Wiring diagram 1 - M2

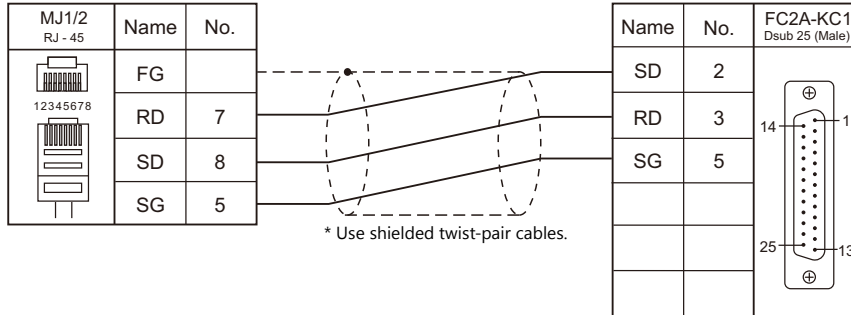

Wiring diagram 2 - M2

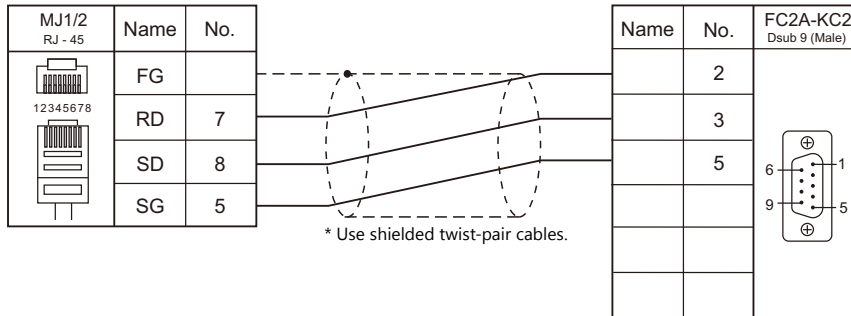

Wiring diagram 3 - M2

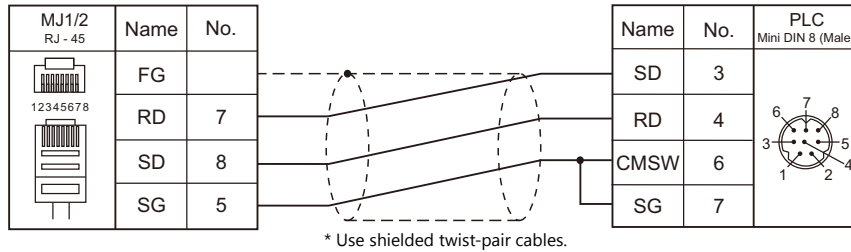

Wiring diagram 4 - M2

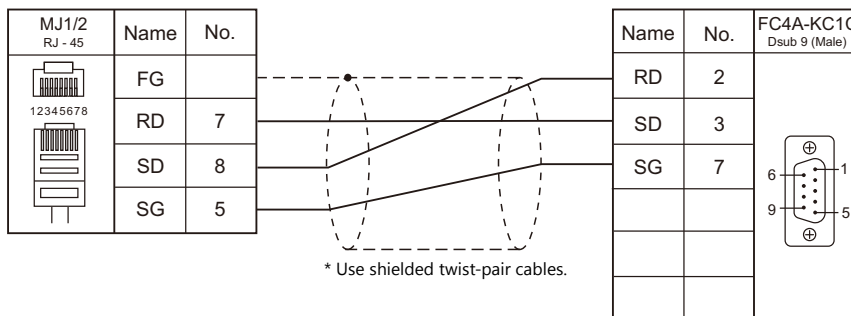

Wiring diagram 5 - M2

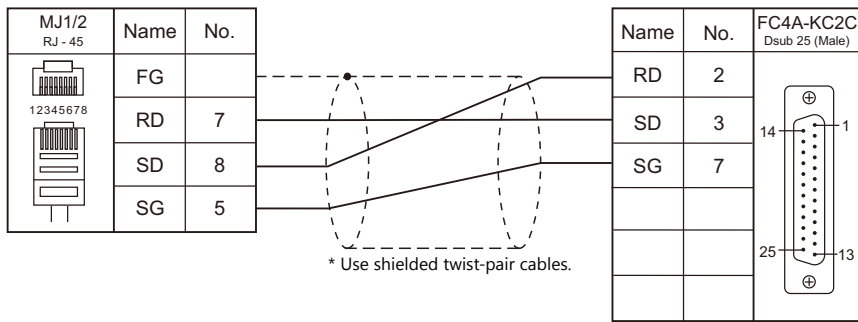

Wiring diagram 6 - M2

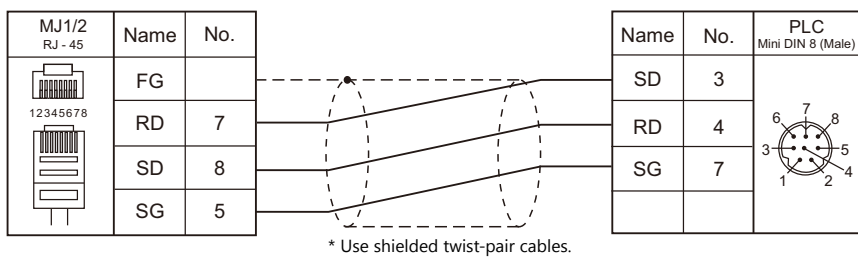

Wiring diagram 7 - M2

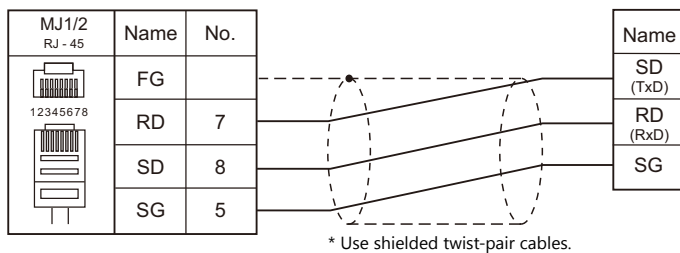

RS-422/RS-485

Wiring diagram 1 - M4

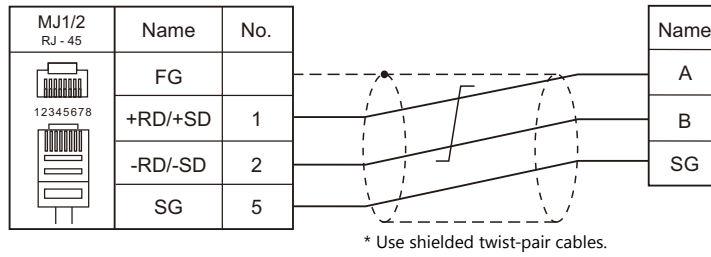

Wiring diagram 2 - M4

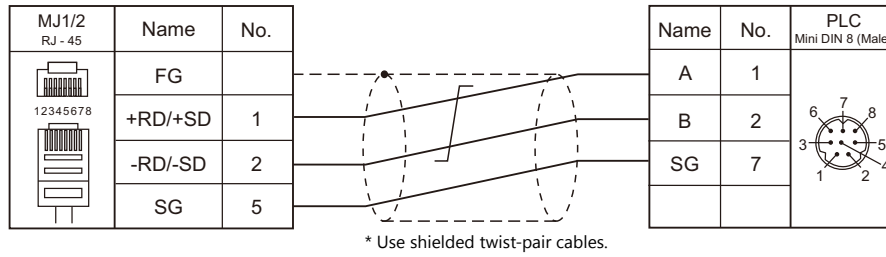

MEMO

Please use this page freely.

4. JTEKT

4.1 PLC Connection

4.1 PLC Connection

The PLC models shown below can be connected.

Serial Connection

PLC Selection on the Editor	PLC	Unit/Port	Signal Level	Connection		Ladder Transfer ^{*1}
				CN1	MJ1/MJ2	
TOYOPUC	PC2 L2	PC/CMP-LINK (TPU-5174)	RS-485	Wiring diagram 1 - C4	Wiring diagram 1 - M4	×
		PC/CMP2-LINK (TPU-5138)				
		3PORT-LINK (TLU-2769)				
		2PORT-LINK (TLU-2695)				
	PC3J/2J	PC/CMP-LINK (THU-2755)				
		PC/CMP2-LINK (THU-5139)				
		2PORT-LINK (THU-2927)				
	PC3J	Built-in link (L1) (TIC-5339)				
		Optional link (L2) (TIU-5366)				
	PC3JL	Built-in link (L1) (TIC-5783)				
		Optional link (L2) (TIC-5783)				
	PC3JD	Built-in link (L1) (TIC-5642)				

*1 For the ladder transfer function, see the V9 Series Reference Manual.

Ethernet Connection

PLC Selection on the Editor	CPU	Unit/Port	TCP/IP	UDP/IP	Port No.	Keep Alive ^{*2}	Ladder Transfer ^{*3}
TOYOPUC (Ethernet)	PC3J PC2 ^{*1}	FL/ET-T-V2 (THU-5998)	×	○	As desired 1025 to 65534 (Max. 8 units)	○	×
		FL/ET-T-V2H (THU-6289)					
		EN-I/F-T (THU-5781)					
TOYOPUC (Ethernet PC10 mode)	PC10G (version 3.00 or later) PC10GE	Built-in Ethernet (L1/L2)	×	○	As desired 1025 to 65534 (Max. 32 units)	○	×

*1 The PC2J CPU may not be used depending on the CPU version. For more information, refer to the PLC manual issued by the manufacturer.

*2 For KeepAlive functions, see "1.3.2 Ethernet Communication".

*3 For the ladder transfer function, see the V9 Series Reference Manual.

4.1.1 TOYOPUC

Communication Setting

Editor

Communication setting

(Underlined setting: default)

Item	Setting	Remarks
Connection Mode	<u>1</u> : 1 / 1 : n / Multi-link / Multi-link2 / Multi-link2 (Ethernet) / 1 : n Multi-link2 (Ethernet)	
Signal Level	RS-422/485	
Baud Rate	4800 / 9600 / <u>19200</u> / 38400 / 57600 / 115k bps	
Parity	<u>Even</u>	
Data Length	<u>7</u> / 8 bits	
Stop Bit	1 / <u>2</u> bits	
Target Port No.	<u>0</u> to 31	
Transmission Mode	<u>Data Area Single</u> / Data Area Division	Select [Data Area Single] for PL2/L2.

PLC

Built-in Link / Optional Link

Hellowin link parameter setting

Item	Setting	Remarks
Rack No.	Built-in	
Slot No.	For the built-in link: standard For the optional link: option	
Link Module Name	Computer link	
Station No.	0 to 37 (octal)	
Data Length	<u>7</u> / 8 bits	ASCII
Stop Bit	1 / <u>2</u> bits	
Baud Rate	4800 / 9600 / <u>19200</u> / 38400 / 57600 / 115k bps	
2-wire/4-wire	2-wire system	Can be selected only for "TIC-5783". Set the 2W/4W change-over switch to "2W".

* The parity setting is fixed to even.

TLU-2769 / TLU-2695

Rotary switch

Switch	Setting	Remarks
SW1	0	Station 0 Set the number from 00 to 37 in octal notation. SW1 denotes the higher-order digit, and SW2 denotes the lower-order digit.
SW2	0	
SW3	1	Baud rate 1: 19200, 2: 9600, 3: 4800

Short bar

SET No.	Setting	Contents
SET2	ON	Data length: 7 bits
SET3	ON	Stop bit: 2 bits
SET4	CMP-LINK	Card type: computer link

THU-2755 / THU-5139 / THU-2927**Rotary switch**

Switch	Setting	Remarks
SW1	0	Station 0 Set the number from 00 to 37 in octal notation. SW1 denotes the higher-order digit, and SW2 denotes the lower-order digit.
SW2	0	
SW3	1	Baud rate 1: 19200, 2: 9600, 3: 4800

DIP switch

Switch No.	Setting	Contents
SW4-4	ON	Data length: 7 bits
SW4-3	OFF	Stop bit: 2 bits
SW4-2	ON	Module selection: computer link
SW4-1	OFF	2-wire system or not used

Available Device Memory

The available setting range of device memory varies depending on the PLC model. Be sure to set within the range available for the PLC to be used. Use [TYPE] when assigning indirect device memory for macro programs.

Device Memory	TYPE	Remarks
D (data register)	00H	PRG No. when [Data Area Division] is selected
R (link register)	01H	PRG No. when [Data Area Division] is selected
B (file register)	02H	PRG No. when [Data Area Division] is selected
N (current value register)	03H	PRG No. when [Data Area Division] is selected
X (input)	04H	WX as word device
Y (output)	05H	WY as word device
M (internal relay)	06H	WM as word device, PRG No. when [Data Area Division] is selected
K (keep relay)	07H	WK as word device, PRG No. when [Data Area Division] is selected
L (link relay)	08H	WL as word device, PRG No. when [Data Area Division] is selected
T (timer/contact)	09H	WT as word device, PRG No. when [Data Area Division] is selected
C (counter/contact)	0AH	WC as word device, PRG No. when [Data Area Division] is selected
U (extensional data register)	0BH	
H (extensional set value register)	0CH	
EN (extensional current value register)	0DH	
EX (extensional input)	0EH	WEX as word device
EY (extensional output)	0FH	WEY as word device
EM (extensional internal relay)	10H	WEM as word device
EK (extensional keep relay)	11H	WEK as word device
EL (extensional link relay)	12H	WEL as word device
ET (extensional timer/contact)	13H	WET as word device
EC (extensional counter/contact)	14H	WEC as word device
V (special register)	15H	WV as word device

PRG No. setting

If [Transmission Mode: Data Area Division] is set under [Communication Setting], specify a program number ([PRG No.]) in addition to device type and address number. The assigned device memory is expressed as shown below when editing the screen. The PRG No. is invalid for the device memory in the common area.

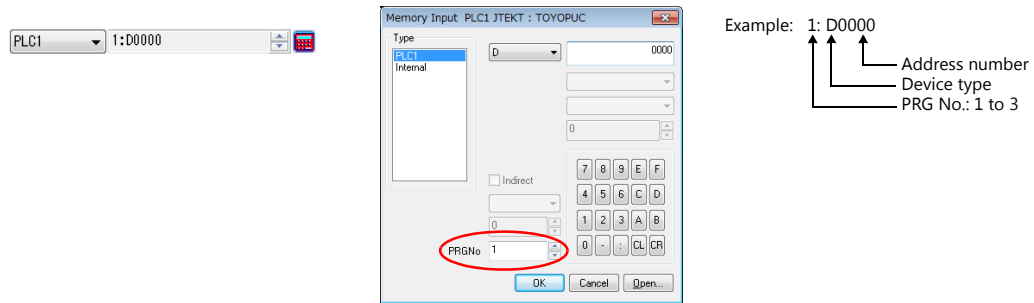

Indirect Device Memory Designation

- For the address number of 0 to 65535:

	15	8	7	0
n+0	Model		Device type	
n+1	Address No.			
n+2	Expansion code *		Bit designation	
n+3	00		Station number	

- For the address number of 65536 or greater:

	15	8	7	0
n+0	Model		Device type	
n+1	Lower address No.			
n+2	Higher address No.			
n+3	Expansion code *		Bit designation	
n+4	00		Station number	

* If [Transmission Mode: Data Area Division] is set under [Communication Setting], specify a program number ([PRG No.]) for the expansion code.

Specify the number obtained by subtracting "1" from the actual program number ([PRG No.]) as defined below.

PRG No. 1: 0
 PRG No. 2: 1
 PRG No. 3: 2

4.1.2 TOYOPUC (Ethernet)

Communication Setting

Editor

Make the following settings on the editor. For more information, see "1.3.2 Ethernet Communication".

- IP address for the V9 unit
 - When specified on the screen program:
[System Setting] → [Hardware Setting] → [Local Port IP Address]
 - When specified on the V9 unit:
Local mode → [LAN Setting]
- Port number for the V9 unit (for communication with PLC)
[System Setting] → [Hardware Setting] → [PLC Properties] → [Communication Setting]
- IP address and port number of the PLC
Register on the [PLC Table] in [System Setting] → [Hardware Setting] → [PLC Properties] → [Target Settings].

PLC

Hellowin

Settings can be made using the software "Hellowin" or ladder programs. For settings using ladder programs, refer to the PLC manual issued by the manufacturer.

I/O module setting

Item	Setting
Identification Code	B3
Module Type	Special / Communication
Module Name	Time chart module, computer link, Ethernet, S-NET

Link parameter setting

Item	Setting
Rack No.	Select a number where the unit is mounted.
Slot No.	Select a number where the unit is mounted.
Link Module Name	Ethernet

Ethernet setting

Item	Setting
Local Node IP Address	Set the IP address of the PLC.
Connection 1 - 8 *	Protocol: UDP Local Node Port No.: Port number of the PLC Other Node Table No.: Table number for which the V9 is registered
Initialization	Initialize using the link parameter

* When multiple V9 units are connected, make the settings for each unit. A maximum of eight units can be connected at one time.

Other node table setting

Item	Setting
Table 1 to 16	Check each box for "Use".
Other Node IP Address	Set the IP address of the V9.
Other Node Port No.	Set the port number of the V9.

Available Device Memory

The available setting range of device memory varies depending on the PLC model. Be sure to set within the range available for the PLC to be used. Use [TYPE] when assigning indirect device memory for macro programs.

Device Memory	TYPE	Remarks
D (data register)	00H	PRG No. when [Data Area Division] is selected
R (link register)	01H	PRG No. when [Data Area Division] is selected
B (file register)	02H	PRG No. when [Data Area Division] is selected
N (current value register)	03H	PRG No. when [Data Area Division] is selected
X (input)	04H	WX as word device
Y (output)	05H	WY as word device
M (internal relay)	06H	WM as word device, PRG No. when [Data Area Division] is selected
K (keep relay)	07H	WK as word device, PRG No. when [Data Area Division] is selected
L (link relay)	08H	WL as word device, PRG No. when [Data Area Division] is selected
T (timer/contact)	09H	WT as word device, PRG No. when [Data Area Division] is selected
C (counter/contact)	0AH	WC as word device, PRG No. when [Data Area Division] is selected
U (extensional data register)	0BH	
H (extensional set value register)	0CH	
EN (extensional current value register)	0DH	
EX (extensional input)	0EH	WEX as word device
EY (extensional output)	0FH	WEY as word device
EM (extensional internal relay)	10H	WEM as word device
EK (extensional keep relay)	11H	WEK as word device
EL (extensional link relay)	12H	WEL as word device
ET (extensional timer/contact)	13H	WET as word device
EC (extensional counter/contact)	14H	WEC as word device
V (special register)	15H	WV as word device

PRG No. setting

If [Transmission Mode: Data Area Division] is set under [Communication Setting], specify a program number ([PRG No.]) in addition to device type and address number. The assigned device memory is expressed as shown below when editing the screen. The PRG No. is invalid for the device memory in the common area.

Example: 1: D0000

- 1: PRG No.
- D: Device type
- 0000: Address number

Indirect Device Memory Designation

- For the address number of 0 to 65535:

	15	8 7	0
n+0	Model		Device type
n+1	Address No.		
n+2	Expansion code *		Bit designation
n+3	00		Station number

- For the address number of 65536 or greater:

	15	8 7	0
n+0	Model		Device type
n+1	Lower address No.		
n+2	Higher address No.		
n+3	Expansion code *		Bit designation
n+4	00		Station number

* If [Transmission Mode: Data Area Division] is set under [Communication Setting], specify a program number ([PRG No.]) for the expansion code.

Specify the number obtained by subtracting "1" from the actual program number ([PRG No.]) as defined below.

- PRG No. 1: 0
- PRG No. 2: 1
- PRG No. 3: 2

4.1.3 TOYOPUC (Ethernet PC10 Mode)

Communication Setting

Editor

Make the following settings on the editor. For more information, see "1.3.2 Ethernet Communication".

- IP address for the V9 unit
 - When specified on the screen program:
[System Setting] → [Hardware Setting] → [Local Port IP Address]
 - When specified on the V9 unit:
Local mode → [LAN Setting]
- Port number for the V9 unit (for communication with PLC)
[System Setting] → [Hardware Setting] → [PLC Properties] → [Communication Setting]
- IP address and port number of the PLC
Register on the [PLC Table] in [System Setting] → [Hardware Setting] → [PLC Properties] → [Target Settings].

PLC

Settings are possible either in the software "PCwin" or ladder programs. For settings using ladder programs, refer to the PLC manual issued by the manufacturer.

Communication Setting Switches L1 and L2

SW	No.	Item	Setting
	1	L3 SN-IF use setting	OFF: Not used (T-OFF)
	2	L1 communication setting	ON: Link parameter (L1 SEL.)
	3	L2 baud rate switching	ON: Auto negotiation (L2 Auto) OFF: 10M bps (10M)
	4	L1 baud rate switching	ON: Auto negotiation (L1 Auto) OFF: 10M bps (10M)

PCwin

Link parameter setting

Item	Setting
Rack No.	Built-in
Slot No.	L1 / L2
Link Module Name	Ethernet (32 ports)

Ethernet setting

Item	Setting
Local Node IP Address	Set the IP address of the PLC.
Setting 1/Setting 2/ Setting 3/Setting 4/	Setting 1: Connection 1 to 8 Setting 2: Connection 9 to 16 Setting 3: Connection 17 to 24 Setting 4: Connection 25 to 32
Connection 1 - 32 *	Protocol: UDP Local Node Port No.: Port number of the PLC Other Node Table No.: Table number for which the V9 is registered
Initialization	Initialize using the link parameter

* When multiple V9 units are connected, make the settings for each unit. A maximum of 32 units can be connected at one time.

Other node table setting

Item	Setting
Setting 1/Setting 2	Setting 1: Table 1 to 16 Setting 2: Table 17 to 32
Table 1 to 32	Check each box for "Use".
Other Node IP Address	Set the IP address of the V9.
Other Node Port No.	Set the port number of the V9.

If "TOYOPUC (Ethernet PC10 mode)" is selected as a connected model in V-SFT and if establishing communication with PC10G or PC10GE is intended, set the following dialogs.

- PC10G: PC10 mode
- PC10GE: PC10 extended mode

PCwin settings

Click [Option] → [Setting] → [Interchangeable]. In the tab window, check either box below.

- PC10G: Check PC10 mode].
- PC10GE: Check PC10 extended mode].

In the [CPU operation mode] dialog, check either [PC10 mode] or [PC10 Extension].

Available Device Memory

The available setting range of device memory varies depending on the PLC model. Be sure to set within the range available for the PLC to be used. Use [TYPE] when assigning indirect device memory for macro programs.

Device Memory	TYPE	Remarks
D (data register)	00H	PRG No. designation
R (link register)	01H	PRG No. designation
N (current value register)	03H	PRG No. designation
X (input)	04H	WX as word device
Y (output)	05H	WY as word device
M (internal relay)	06H	WM as word device, PRG No. designation
K (keep relay)	07H	WK as word device, PRG No. designation
L (link relay)	08H	WL as word device, PRG No. designation
T (timer/contact)	09H	WT as word device, PRG No. designation
C (counter/contact)	0AH	WC as word device, PRG No. designation
U (extension data register)	0BH	
H (extension set value register)	0CH	
EN (extension current value register)	0DH	
EX (extension input)	0EH	WEX as word device
EY (extension output)	0FH	WEY as word device
EM (extension internal relay)	10H	WEM as word device
EK (extension keep relay)	11H	WEK as word device
EL (extension link relay)	12H	WEL as word device
ET (extension timer/contact)	13H	WET as word device
EC (extension counter/contact)	14H	WEC as word device
V (special relay)	15H	WV as word device, PRG No. designation, read only
GX (extension input)	16H	WGX as word device
GY (extension output)	17H	WGY as word device
GM (extension internal relay)	18H	WGM as word device
EB (extension buffer register)	19H	
FR (extension flash register)	1AH	

PRG No. setting

In addition to device type and address number, a program number ([PRG No.]) must be specified. The assigned device memory is expressed as shown below when editing the screen. The PRG No. is invalid for the device memory in the common area.

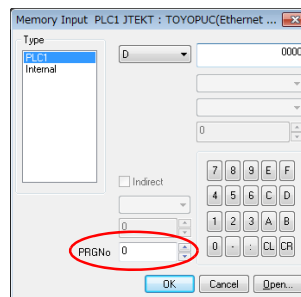

Example: 1: D0000
 ↑ Address number
 ↑ Device type
 ↑ PRG No.: 1 to 3

Indirect Device Memory Designation

- For the address number of 0 to 65535:

	15	8 7	0
n+0	Model		Device type
n+1	Address No.		
n+2	Expansion code *		Bit designation
n+3	00		Station number

- For the address number of 65536 or greater:

	15	8 7	0
n+0	Model		Device type
n+1	Lower address No.		
n+2	Higher address No.		
n+3	Expansion code *		Bit designation
n+4	00		Station number

* Specify a program number ([PRG No.]) for the expansion code. Specify the number obtained by subtracting "1" from the actual program number ([PRG No.]) as defined below.

- PRG No. 1: 0
- PRG No. 2: 1
- PRG No. 3: 2

PLC_CTL

Macro command "PLC_CTL F0 F1 F2"

Contents	F0	F1 (= \$u n)	F2																							
Write to FR register flash memory *	1 to 8 (PLC1 to 8)	n	Station number																							
		n+1	Command: 0																							
		n+2	ExNo. (HEX) <table border="1" style="margin-left: 20px;"> <thead> <tr> <th>ExNo.</th> <th>Address</th> </tr> </thead> <tbody> <tr> <td>40H</td> <td>FR000000 to FR007FFF</td> </tr> <tr> <td>41H</td> <td>FR008000 to FR00FFFF</td> </tr> <tr> <td>42H</td> <td>FR010000 to FR017FFF</td> </tr> <tr> <td>43H</td> <td>FR018000 to FR01FFFF</td> </tr> <tr> <td>:</td> <td>:</td> </tr> <tr> <td>:</td> <td>:</td> </tr> <tr> <td>7EH</td> <td>FR1F0000 to FR1F7FFF</td> </tr> <tr> <td>7FH</td> <td>FR1F8000 to FR1FFFFF</td> </tr> </tbody> </table>	ExNo.	Address	40H	FR000000 to FR007FFF	41H	FR008000 to FR00FFFF	42H	FR010000 to FR017FFF	43H	FR018000 to FR01FFFF	:	:	:	:	7EH	FR1F0000 to FR1F7FFF	7FH	FR1F8000 to FR1FFFFF	3				
		ExNo.	Address																							
40H	FR000000 to FR007FFF																									
41H	FR008000 to FR00FFFF																									
42H	FR010000 to FR017FFF																									
43H	FR018000 to FR01FFFF																									
:	:																									
:	:																									
7EH	FR1F0000 to FR1F7FFF																									
7FH	FR1F8000 to FR1FFFFF																									
n+3	Execution result 0: Successful 1: Error 2: Writing																									
CPU status readout	1 to 8 (PLC1 to 8)	n	Station number																							
		n+1	Command: 1																							
		n+2	Data 1 <table style="margin-left: 20px;"> <tr> <td style="text-align: center;">15</td><td style="text-align: center;">~</td><td style="text-align: center;">8</td><td style="text-align: center;">7</td><td style="text-align: center;">6</td><td style="text-align: center;">5</td><td style="text-align: center;">4</td><td style="text-align: center;">3</td><td style="text-align: center;">2</td><td style="text-align: center;">1</td><td style="text-align: center;">0</td> </tr> <tr> <td colspan="2" style="text-align: center;">0 fixed</td> <td style="text-align: center;">Running</td> <td style="text-align: center;">Stopped</td> <td style="text-align: center;">Stop request continued</td> <td style="text-align: center;">Pseudo stop</td> <td style="text-align: center;">Debug mode</td> <td style="text-align: center;">I/O monitor user mode</td> <td style="text-align: center;">PC3 mode</td> <td style="text-align: center;">PC10 mode</td> <td></td> </tr> </table>	15	~	8	7	6	5	4	3	2	1	0	0 fixed		Running	Stopped	Stop request continued	Pseudo stop	Debug mode	I/O monitor user mode	PC3 mode	PC10 mode		2
		15	~	8	7	6	5	4	3	2	1	0														
0 fixed		Running	Stopped	Stop request continued	Pseudo stop	Debug mode	I/O monitor user mode	PC3 mode	PC10 mode																	
n+3	Data 2 <table style="margin-left: 20px;"> <tr> <td style="text-align: center;">15</td><td style="text-align: center;">~</td><td style="text-align: center;">8</td><td style="text-align: center;">7</td><td style="text-align: center;">6</td><td style="text-align: center;">5</td><td style="text-align: center;">4</td><td style="text-align: center;">3</td><td style="text-align: center;">2</td><td style="text-align: center;">1</td><td style="text-align: center;">0</td> </tr> <tr> <td colspan="2" style="text-align: center;">0 fixed</td> <td style="text-align: center;">Severe failure</td> <td style="text-align: center;">Alarm Minor failure</td> <td style="text-align: center;">I/O assignment parameter changed</td> <td style="text-align: center;">With memory card</td> <td style="text-align: center;">Test mode</td> <td></td><td></td><td></td><td></td> </tr> </table>	15	~	8	7	6	5	4	3	2	1	0	0 fixed		Severe failure	Alarm Minor failure	I/O assignment parameter changed	With memory card	Test mode							
15	~	8	7	6	5	4	3	2	1	0																
0 fixed		Severe failure	Alarm Minor failure	I/O assignment parameter changed	With memory card	Test mode																				

Contents	F0	F1 (= \$u n)	F2
CPU status readout	1 to 8 (PLC1 to 8)	<p>n+4</p> <p>Data 3</p>	2
		<p>n+5</p> <p>Data 4</p>	
		<p>n+6</p> <p>Data 5</p>	
		<p>n+7</p> <p>Data 6</p>	
		<p>n+8</p> <p>Data 7</p>	
		<p>n+9</p> <p>Data 8</p>	

Return data: Data stored to V series from PC10G

* Writing to the FR register flash memory is performed in units of 64 KB. When writing to addresses in memory, specify an "Ex No." corresponding to the desired addresses for 64 KB of data. Communication between the V series and PC10G pauses during writing.

4.1.4 Wiring Diagrams

When Connected at CN1:

RS-422/RS-485

Wiring diagram 1 - C4

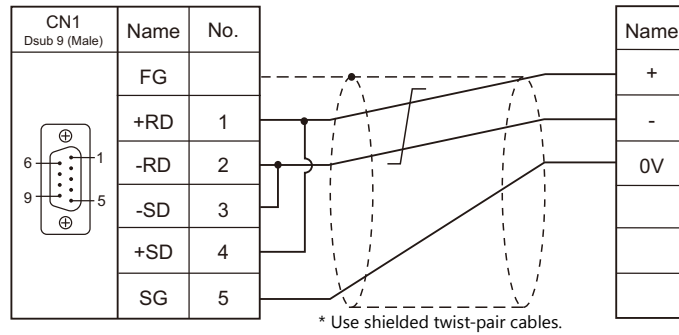

When Connected at MJ1/MJ2:

RS-422/RS-485

Wiring diagram 1 - M4

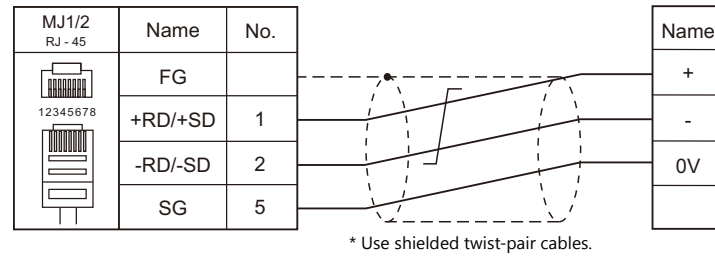

MEMO

Please use this page freely.

5. KEYENCE

5.1 PLC Connection

5.1 PLC Connection

Serial Connection

PLC Selection on the Editor	CPU	Unit/Port		Signal Level	Connection		Ladder Transfer ^{*2}
					CN1	MJ1/MJ2	
KZ series link	KZ-300 KZ-350	KZ-L2	Port 1	RS-232C	Wiring diagram 5 - C2	Wiring diagram 5 - M2	×
			Port 2	RS-232C	Wiring diagram 4 - C2	Wiring diagram 4 - M2	
KZ-A500 CPU	KZ-A500	CPU modular port		RS-422	Wiring diagram 1 - C2	Wiring diagram 1 - M2	×
				RS-232C	Hakko Electronics' cable "D9-MB-CPUQ" + Keyence's "KZ-C20"		
KV10/24CPU	KV-10 KV-24 KV-40	CPU modular port		RS-232C	Wiring diagram 2 - C2 ^{*1} or	Wiring diagram 2 - M2	×
K15V-700	KV-700	CPU modular port		RS-232C	Hakko Electronics' cable "D9-KI2-KV-2M"		
		KV-L20 KV-L20R	Port 1	RS-232C	Wiring diagram 3 - C2	Wiring diagram 3 - M2	
			Port 2	RS-232C	Wiring diagram 4 - C2	Wiring diagram 4 - M2	
KV-1000	KV-1000	CPU modular port		RS-422	Wiring diagram 1 - C4	×	
		KV-L20R	Port 1	RS-232C	Wiring diagram 3 - C2	Wiring diagram 3 - M2	
			Port 2	RS-232C	Wiring diagram 4 - C2	Wiring diagram 4 - M2	
KV-3000/5000	KV-3000 KV-5000	CPU modular port		RS-422	Wiring diagram 1 - C4	×	
		KV-L20V	Port 1	RS-232C	Wiring diagram 3 - C2	Wiring diagram 3 - M2	
			Port 2	RS-232C	Wiring diagram 4 - C2	Wiring diagram 4 - M2	

*1 Can be connected using the Keyence's cable "OP-26487" + connector "OP-26486" + D-sub gender changer (9-pin, female-to-male) commercially available.

Manufacturer	Model
Black Box	FA440-R2
Misumi	DGC-9PP

*2 For the ladder transfer function, see the V9 Series Reference Manual.

Ethernet Connection

PLC Selection on the Editor	CPU	Unit	TCP/IP	UDP/IP	Port No.	Keep Alive ^{*1}	Ladder Transfer ^{*2}
KV-700 (Ethernet TCP/IP)	KV-700	KV-LE20	○	×	8500	○	×
KV-1000 (Ethernet TCP/IP)	KV-1000		○	×	8500		
KV-3000/5000 (Ethernet TCP/IP)	KV-3000 KV-5000	KV-LE20V	○	×	8500		
	KV-5000	CPU (built-in)					

*1 For KeepAlive functions, see "1.3.2 Ethernet Communication".

*2 For the ladder transfer function, see the V9 Series Reference Manual.

5.1.1 KZ Series Link

Communication Setting

Editor

Communication setting

(Underlined setting: default)

Item	Setting	Remarks
Connection Mode	<u>1</u> : 1 / 1 : n / Multi-link2 / Multi-link2 (Ethernet) / 1 : n Multi-link2 (Ethernet)	
Signal Level	<u>RS-232C</u> / RS-422/485	
Baud Rate	4800 / 9600 / <u>19200</u> / 38400 bps	
Data Length	<u>7</u> / 8 bits	
Stop Bit	1 / <u>2</u> bits	
Parity	None / Odd / <u>Even</u>	
Target Port No.	<u>0</u> to 9	

PLC

Port 1

Operation mode setting switch (SET A)

SET A	Item	Setting
	A1	OFF
	A2	ON
	Port 1	Link mode

Communication parameter setting switch (SET B)

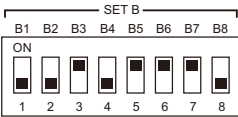
SET B	Item	Setting	Remarks																				
	B1	<table border="1"> <thead> <tr> <th>B1</th> <th>B2</th> <th>B3</th> <th>Baud Rate</th> </tr> </thead> <tbody> <tr> <td>OFF</td> <td>ON</td> <td>OFF</td> <td>4800 bps</td> </tr> <tr> <td>ON</td> <td>ON</td> <td>OFF</td> <td>9600 bps</td> </tr> <tr> <td>OFF</td> <td>OFF</td> <td>ON</td> <td>19200 bps</td> </tr> <tr> <td>OFF</td> <td>ON</td> <td>ON</td> <td>38400 bps</td> </tr> </tbody> </table>	B1	B2	B3	Baud Rate	OFF	ON	OFF	4800 bps	ON	ON	OFF	9600 bps	OFF	OFF	ON	19200 bps	OFF	ON	ON	38400 bps	Common to Port 1 and 2
	B1		B2	B3	Baud Rate																		
	OFF		ON	OFF	4800 bps																		
	ON		ON	OFF	9600 bps																		
	OFF	OFF	ON	19200 bps																			
	OFF	ON	ON	38400 bps																			
	B2	Baud rate																					
	B3																						
B4	OFF: 7 bit ON: 8 bit																						
B5	<table border="1"> <thead> <tr> <th>B5</th> <th>B6</th> <th>Parity</th> </tr> </thead> <tbody> <tr> <td>OFF</td> <td>OFF</td> <td>None</td> </tr> <tr> <td>ON</td> <td>OFF</td> <td>Odd</td> </tr> <tr> <td>ON</td> <td>ON</td> <td>Even</td> </tr> </tbody> </table>		B5	B6	Parity	OFF	OFF	None	ON	OFF	Odd	ON	ON	Even									
B5		B6	Parity																				
OFF		OFF	None																				
ON	OFF	Odd																					
ON	ON	Even																					
B6	Parity check																						
B7		OFF: 1 bit ON: 2 bit																					
B8	System reserve	Fixed to OFF																					

Port 2

Port select switch (INTERFACE)

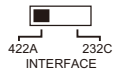
INTERFACE	Item	Setting
	Signal level switch	422A: RS-422 232C: RS-232C

Operation mode setting switch (SET A)

SET A	Item	Setting
	A3	OFF
	A4	ON
	Port 2	Link mode

Terminator select switch (TERMINATOR)

TERMINATOR	Item	Setting	Remarks
	Terminating resistance	OFF: Without terminating resistance ON: With terminating resistance	Turn off for RS-232C connection.

Station number setting switch (STATION No.)

STATION No.	Item	Setting
	Target port No.	0 to 9

Communication parameter setting switch (SET B)

SET B	Item	Setting	Remarks																				
	B1	<table border="1"> <thead> <tr> <th>B1</th> <th>B2</th> <th>B3</th> <th>Baud Rate</th> </tr> </thead> <tbody> <tr> <td>OFF</td> <td>ON</td> <td>OFF</td> <td>4800 bps</td> </tr> <tr> <td>ON</td> <td>ON</td> <td>OFF</td> <td>9600 bps</td> </tr> <tr> <td>OFF</td> <td>OFF</td> <td>ON</td> <td>19200 bps</td> </tr> <tr> <td>OFF</td> <td>ON</td> <td>ON</td> <td>38400 bps</td> </tr> </tbody> </table>	B1	B2	B3	Baud Rate	OFF	ON	OFF	4800 bps	ON	ON	OFF	9600 bps	OFF	OFF	ON	19200 bps	OFF	ON	ON	38400 bps	Common to Port 1 and 2
	B1		B2	B3	Baud Rate																		
	OFF		ON	OFF	4800 bps																		
	ON		ON	OFF	9600 bps																		
	OFF	OFF	ON	19200 bps																			
	OFF	ON	ON	38400 bps																			
	B2	Baud rate																					
	B3	Baud rate																					
B4	Bit length	OFF: 7 bits ON: 8 bits																					
B5	Parity check	<table border="1"> <thead> <tr> <th>B5</th> <th>B6</th> <th>Parity</th> </tr> </thead> <tbody> <tr> <td>OFF</td> <td>OFF</td> <td>None</td> </tr> <tr> <td>ON</td> <td>OFF</td> <td>Odd</td> </tr> <tr> <td>ON</td> <td>ON</td> <td>Even</td> </tr> </tbody> </table>	B5	B6	Parity	OFF	OFF	None	ON	OFF	Odd	ON	ON	Even									
B5		B6	Parity																				
OFF		OFF	None																				
ON	OFF	Odd																					
ON	ON	Even																					
B6																							
B7	Stop bit	OFF: 1 bit ON: 2 bits																					
B8	System reserve	Fixed to OFF																					

Calendar

This model is not equipped with the calendar function. Use the calendar function of the V series.

Available Device Memory

The available setting range of device memory varies depending on the PLC model. Be sure to set within the range available for the PLC to be used. Use [TYPE] when assigning indirect device memory for macro programs.

Device Memory	TYPE	Remarks
D (data memory)	00H	
CH (input/output/internal auxiliary relay)	01H	

5.1.2 KZ-A500 CPU

Communication Setting

Editor

Communication setting

(Underlined setting: default)

Item	Setting	Remarks
Connection Mode	<u>1:1</u> / Multi-link2 / Multi-link2 (Ethernet)	
Signal Level	RS-232C / <u>RS-422/485</u>	
Baud Rate	4800 / <u>9600</u> / 19200 / 38400 bps	9600 bps only valid when a signal level is RS-422/485.
Data Length	8 bits	
Stop Bit	1 bit	
Parity	Odd	

PLC

Port setting switch

SW1	SW2	Baud Rate
ON	OFF	4800 bps
OFF	OFF	9600 bps
OFF	ON	19200 bps
ON	ON	38400 bps

Available Device Memory

The available setting range of device memory varies depending on the PLC model. Be sure to set within the range available for the PLC to be used. Use [TYPE] when assigning indirect device memory for macro programs.

Device Memory	TYPE	Remarks
D (data register)	00H	
W (link register)	01H	
R (file register)	02H	
TN (timer/current value)	03H	
CN (counter/current value)	04H	
M (internal relay)	06H	
L (latch relay)	07H	
B (link relay)	08H	
X (input)	09H	
Y (output)	0AH	
TS (timer/contact)	0BH	
TC (timer/coil)	0CH	
CS (counter/contact)	0DH	
CC (counter/coil)	0EH	

5.1.3 KV10/24 CPU

Communication Setting

Editor

Communication setting

(Underlined setting: default)

Item	Setting	Remarks
Connection Mode	<u>1:1</u> / Multi-link2 / Multi-link2 (Ethernet)	
Signal Level	RS-232C	
Baud Rate	9600 / 19200 / 38400 / <u>57600</u> bps	If a baud rate higher than 57600 bps is set, communication is performed at 9600 bps.
Data Length	8 bits	
Stop Bit	1 bit	
Parity	Even	
Target Port No.	0	

PLC

No particular setting is necessary on the PLC.

Available Device Memory

The available setting range of device memory varies depending on the PLC model. Be sure to set within the range available for the PLC to be used. Use [TYPE] when assigning indirect device memory for macro programs.

Device Memory	TYPE	Remarks
DM (data memory)	00H	
CH (input/output/internal auxiliary relay)	01H	
TC (timer/current value)	02H	
CC (counter/current value)	03H	
TS (timer/set value)	04H	
CS (counter/set value)	05H	
T (timer/contact)	06H	
C (counter/contact)	07H	
TM (temporary data memory)	08H	

5.1.4 KV-700

Communication Setting

Editor

Communication setting

(Underlined setting: default)

Item	Setting	Remarks
Connection Mode	<u>1:1</u> / Multi-link2 / Multi-link2 (Ethernet)	
Signal Level	<u>RS-232C</u> / RS-422/485	
Baud Rate	9600 / 19200 / 38400 / <u>57600</u> bps	
Data Length	8 bits	
Stop Bit	1 bit	
Parity	Even	
Target Port No.	<u>0</u> to 31	

PLC

KV-700 (CPU Modular Port)

No particular setting is necessary on the PLC.

KV-L20

Unit editor setting

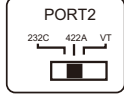
Port	Item	Setting	Remarks
Port 1	Operation Mode	KV BUILDER Mode	
	RS/CS Flow Control	No	
Port 2	Operation Mode	KV BUILDER Mode	
	Interface	RS-232C / RS-422A	Change the setting using the PORT 2 selector switch attached to the side. 
	Station No.	0 to 9	

* These settings can be checked on the access window of the CPU. For more information, refer to the PLC manual issued by the manufacturer.

KV-L20R

Unit editor setting

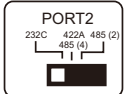
Port	Item	Setting	Remarks
Basic Port	Station No.	0 to 9	Common to Port 1 and 2.
Port 1	Operation Mode	KV BUILDER/KV STUDIO Mode	
	RS/CS Flow Control	No	
Port 2	Operation Mode	KV BUILDER/KV STUDIO Mode	
	Interface	RS-232C/RS-422A/485 (4-wire system)	PORT 2 selector switch attached to the side 

* These settings can be checked on the access window of the CPU. For more information, refer to the PLC manual issued by the manufacturer.

Available Device Memory

The available setting range of device memory varies depending on the PLC model. Be sure to set within the range available for the PLC to be used. Use [TYPE] when assigning indirect device memory for macro programs.

Device Memory	TYPE	Remarks
DM (data memory)	00H	
R (input/output/internal auxiliary/special relay)	01H	
TC (timer/current value)	02H	
CC (counter/current value)	03H	
TS (timer/set value)	04H	
CS (counter/set value)	05H	
T (timer/contact)	06H	
C (counter/contact)	07H	
TM (temporary data memory)	08H	
CTH (high-speed counter/current value)	09H	
CTC (high-speed counter comparator/set value)	0AH	
CT (high-speed counter comparator/contact)	0BH	
CR (control relay)	0CH	
CM (control memory)	0DH	

5.1.5 KV-700 (Ethernet TCP/IP)

Communication Setting

Editor

Make the following settings on the editor. For more information, see "1.3.2 Ethernet Communication".

- IP address for the V9 unit
 - When specified on the screen program:
[System Setting] → [Hardware Setting] → [Local Port IP Address]
 - When specified on the V9 unit:
Local mode → [LAN Setting]
- Port number for the V9 unit (for communication with PLC)
[System Setting] → [Hardware Setting] → [PLC Properties] → [Communication Setting]
- IP address and port number of the PLC
Register on the [PLC Table] in [System Setting] → [Hardware Setting] → [PLC Properties] → [Target Settings].

PLC

KV-LE20

Unit editor setting

(Underlined setting: default)

Item	Setting	Remarks
Baud Rate	<u>100/10 Mbps Auto</u> / 10 Mbps	Set to "10 Mbps" (fixed) if the communication status is unstable.
IP Address	0.0.0.0 to 255.255.255.255	
Subnet Mask	0.0.0.0 to 255.255.255.255	
Port Number (KVS, DB)	<u>8500</u>	TCP/IP

* These settings can be checked on the access window of the CPU. For more information, refer to the PLC manual issued by the manufacturer.

Available Device Memory

The available setting range of device memory varies depending on the PLC model. Be sure to set within the range available for the PLC to be used. Use [TYPE] when assigning indirect device memory for macro programs.

Device Memory	TYPE	Remarks
DM (data memory)	00H	
R (input/output/internal auxiliary/special relay)	01H	
TC (timer/current value)	02H	
CC (counter/current value)	03H	
TS (timer/set value)	04H	
CS (counter/set value)	05H	
T (timer/contact)	06H	
C (counter/contact)	07H	
TM (temporary data memory)	08H	
CTH (high-speed counter/current value)	09H	
CTC (high-speed counter comparator/set value)	0AH	
CT (high-speed counter comparator/contact)	0BH	
CR (control relay)	0CH	
CM (control memory)	0DH	

5.1.6 KV-1000

Communication Setting

Editor

Communication setting

(Underlined setting: default)

Item	Setting	Remarks
Connection Mode	<u>1:1</u> / Multi-link2 / Multi-link2 (Ethernet)	
Signal Level	<u>RS-232C</u> / RS-422/485	
Baud Rate	9600 / 19200 / 38400 / 57600 / <u>115K</u> bps	
Data Length	8 bits	
Stop Bit	1 bit	
Parity	Even	
Target Port No.	<u>0</u> to 31	

PLC

KV-1000 (CPU Modular Port)

No particular setting is necessary on the PLC.

KV-L20R

Unit editor setting

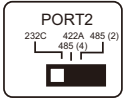
Port	Item	Setting	Remarks
Basic Port	Station No.	0 to 9	Common to Port 1 and 2.
Port 1	Operation Mode	KV BUILDER/KV STUDIO Mode	
	RS/CS Flow Control	No	
Port 2	Operation Mode	KV BUILDER/KV STUDIO Mode	
	Interface	RS-232C/ RS-422A/485 (4-wire system)	PORT 2 selector switch attached to the side 

* These settings can be checked on the access window of the CPU. For more information, refer to the PLC manual issued by the manufacturer.

Available Device Memory

The available setting range of device memory varies depending on the PLC model. Be sure to set within the range available for the PLC to be used. Use [TYPE] when assigning indirect device memory for macro programs.

Device Memory	TYPE	Remarks
DM (data memory)	00H	
R (input/output/internal auxiliary/special relay)	01H	
TC (timer/current value)	02H	
CC (counter/current value)	03H	
TS (timer/set value)	04H	
CS (counter/set value)	05H	
T (timer/contact)	06H	
C (counter/contact)	07H	
TM (temporary data memory)	08H	
CTH (high-speed counter/current value)	09H	
CTC (high-speed counter comparator/set value)	0AH	
CT (high-speed counter comparator/contact)	0BH	
CR (control relay)	0CH	
CM (control memory)	0DH	
MR (internal auxiliary relay)	0EH	
LR (latch relay)	0FH	
EM (extended data memory 1)	10H	
FM (extended data memory 2)	11H	
Z (index register)	12H	

5.1.7 KV-1000 (Ethernet TCP/IP)

Communication Setting

Editor

Make the following settings on the editor. For more information, see "1.3.2 Ethernet Communication".

- IP address for the V9 unit
 - When specified on the screen program:
[System Setting] → [Hardware Setting] → [Local Port IP Address]
 - When specified on the V9 unit:
Local mode → [LAN Setting]
- Port number for the V9 unit (for communication with PLC)
[System Setting] → [Hardware Setting] → [PLC Properties] → [Communication Setting]
- IP address and port number of the PLC
Register on the [PLC Table] in [System Setting] → [Hardware Setting] → [PLC Properties] → [Target Settings].

PLC

The communication setting is the same as the one described in "5.1.5 KV-700 (Ethernet TCP/IP)".

Available Device Memory

The available setting range of device memory varies depending on the PLC model. Be sure to set within the range available for the PLC to be used. Use [TYPE] when assigning indirect device memory for macro programs.

	Device Memory	TYPE	Remarks
DM	(data memory)	00H	
R	(input/output/internal auxiliary/special relay)	01H	
TC	(timer/current value)	02H	
CC	(counter/current value)	03H	
TS	(timer/set value)	04H	
CS	(counter/set value)	05H	
T	(timer/contact)	06H	
C	(counter/contact)	07H	
TM	(temporary data memory)	08H	
CTH	(high-speed counter/current value)	09H	
CTC	(high-speed counter comparator/set value)	0AH	
CT	(high-speed counter comparator/contact)	0BH	
CR	(control relay)	0CH	
CM	(control memory)	0DH	
MR	(internal auxiliary relay)	0EH	
LR	(latch relay)	0FH	
EM	(extended data memory 1)	10H	
FM	(extended data memory 2)	11H	
Z	(index register)	12H	

5.1.8 KV-3000 / 5000

Communication Setting

Editor

Communication setting

(Underlined setting: default)

Item	Setting	Remarks
Connection Mode	<u>1:1</u> / Multi-link2 / Multi-link2 (Ethernet)	
Signal Level	<u>RS-232C</u> / RS-422/485	
Baud Rate	9600 / 19200 / 38400 / 57600 / <u>115K</u> bps	
Data Length	8 bits	
Stop Bit	1 bit	
Parity	Even	
Target Port No.	<u>0</u> to 31	

PLC

KV-3000 (CPU Modular Port)

No particular setting is necessary on the PLC.

KV-L20V

Unit editor setting

Port	Item	Setting	Remarks
Basic Port	Station number	0 to 9	Common to Port 1 and 2.
Port 1	Operation mode	KV BUILDER/KV STUDIO mode	
	RS/CS flow control	No	
Port 2	Operation mode	KV BUILDER/KV STUDIO mode	
	Interface	RS-232C/ RS-422A/485 (4-wire system)	

* These settings can be checked on the access window of the CPU. For more information, refer to the PLC manual issued by the manufacturer.

Available Device Memory

The available setting range of device memory varies depending on the PLC model. Be sure to set within the range available for the PLC to be used. Use [TYPE] when assigning indirect device memory for macro programs.

Device Memory	TYPE	Remarks
DM (data memory)	00H	
R (input/output/internal auxiliary/special relay)	01H	
TC (timer/current value)	02H	Double-word
CC (counter/current value)	03H	Double-word
TS (timer/set value)	04H	Double-word
CS (counter/set value)	05H	Double-word
T (timer/contact)	06H	
C (counter/contact)	07H	
TM (temporary data memory)	08H	
CTH (high-speed counter/current value)	09H	Double-word
CTC (high-speed counter comparator/set value)	0AH	Double-word
CT (high-speed counter comparator/contact)	0BH	
CR (control relay)	0CH	
CM (control memory)	0DH	
MR (internal auxiliary relay)	0EH	
LR (latch relay)	0FH	
EM (extended data memory 1)	10H	
FM (extended data memory 2)	11H	
Z (index register)	12H	Double-word
B (link relay)	13H	
VB (work relay)	14H	
ZF (file register)	15H	
W (link register)	16H	
VM (work memory)	17H	

5.1.9 KV-3000 / 5000 (Ethernet TCP/IP)

Communication Setting

Editor

Make the following settings on the editor. For more information, see "1.3.2 Ethernet Communication".

- IP address for the V9 unit
 - When specified on the screen program:
[System Setting] → [Hardware Setting] → [Local Port IP Address]
 - When specified on the V9 unit:
Local mode → [LAN Setting]
- Port number for the V9 unit (for communication with PLC)
[System Setting] → [Hardware Setting] → [PLC Properties] → [Communication Setting]
- IP address and port number of the PLC
Register on the [PLC Table] in [System Setting] → [Hardware Setting] → [PLC Properties] → [Target Settings].

PLC

The communication setting is the same as the one described in "5.1.5 KV-700 (Ethernet TCP/IP)".

Available Device Memory

The available setting range of device memory varies depending on the PLC model. Be sure to set within the range available for the PLC to be used. Use [TYPE] when assigning indirect device memory for macro programs.

Device Memory	TYPE	Remarks
DM (data memory)	00H	
R (input/output/internal auxiliary/special relay)	01H	
TC (timer/current value)	02H	Double-word
CC (counter/current value)	03H	Double-word
TS (timer/set value)	04H	Double-word
CS (counter/set value)	05H	Double-word
T (timer/contact)	06H	
C (counter/contact)	07H	
TM (temporary data memory)	08H	
CTH (high-speed counter/current value)	09H	Double-word
CTC (high-speed counter comparator/set value)	0AH	Double-word
CT (high-speed counter comparator/contact)	0BH	
CR (control relay)	0CH	
CM (control memory)	0DH	
MR (internal auxiliary relay)	0EH	
LR (latch relay)	0FH	
EM (extended data memory 1)	10H	
FM (extended data memory 2)	11H	
Z (index register)	12H	Double-word
B (link relay)	13H	
VB (work relay)	14H	
ZF (file register)	15H	
W (link register)	16H	
VM (work memory)	17H	

5.1.10 Wiring Diagrams

When Connected at CN1:

RS-232C

Wiring diagram 1 - C2

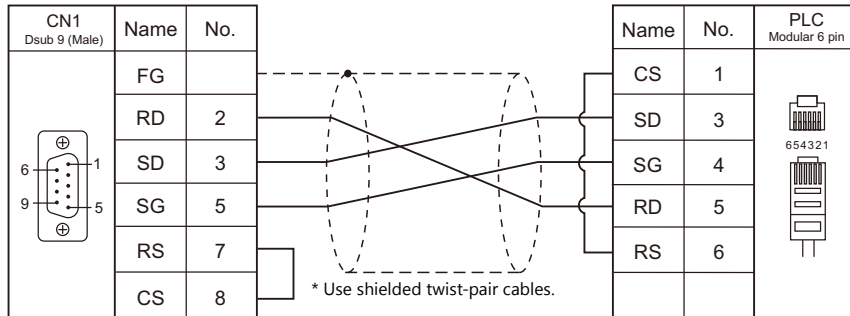

Wiring diagram 2 - C2

Hakko Electronics' cable "D9-KI2-KV-2M"

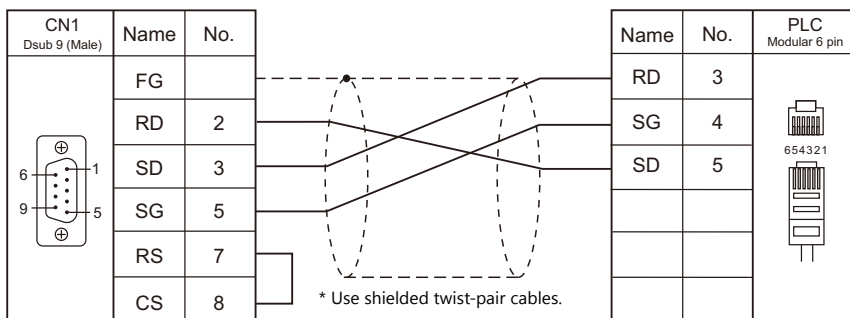

Wiring diagram 3 - C2

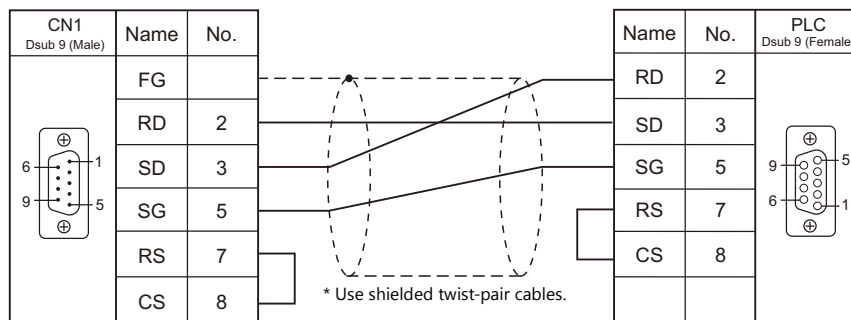

Wiring diagram 4 - C2

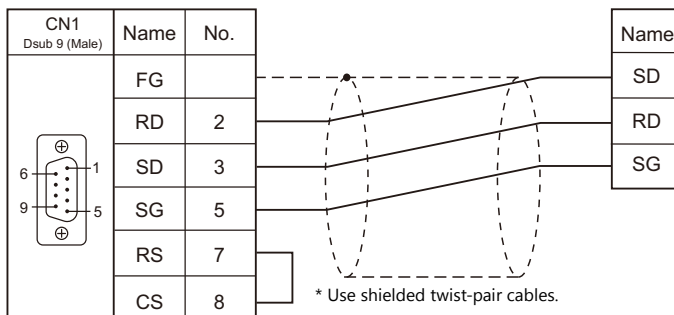

Wiring diagram 5 - C2

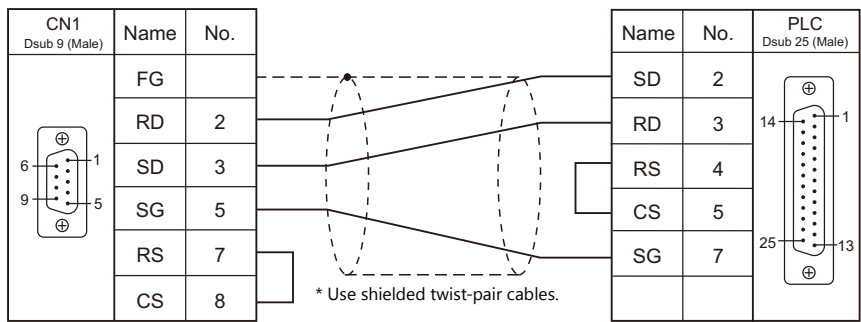

RS-422/RS-485

Wiring diagram 1 - C4

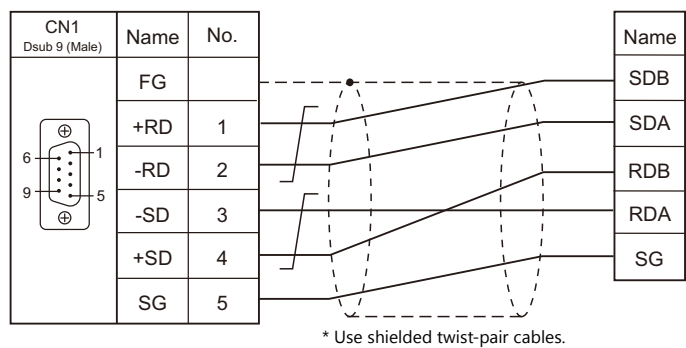

When Connected at MJ1/MJ2:

RS-232C

Wiring diagram 1 - M2

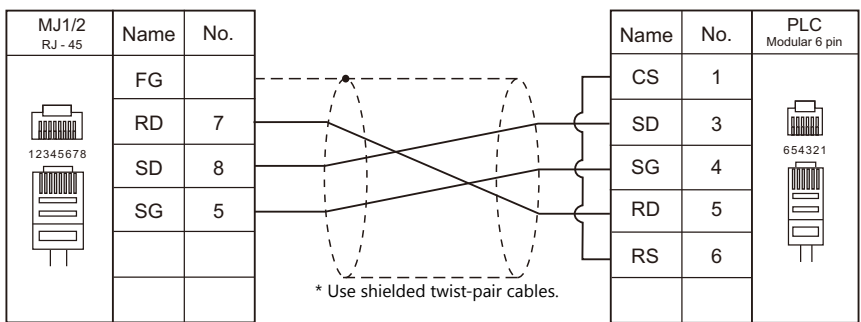

Wiring diagram 2 - M2

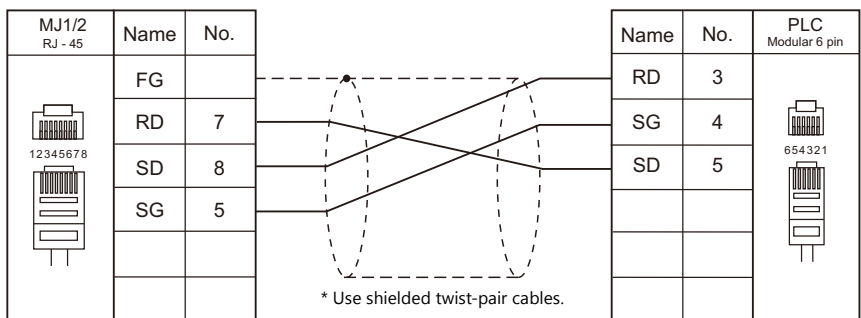

Wiring diagram 3 - M2

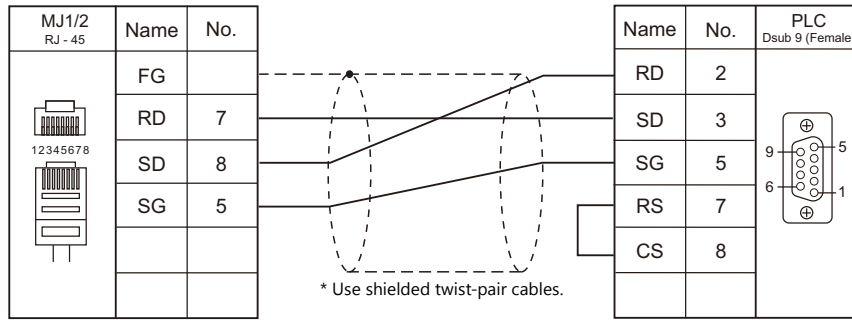

Wiring diagram 4 - M2

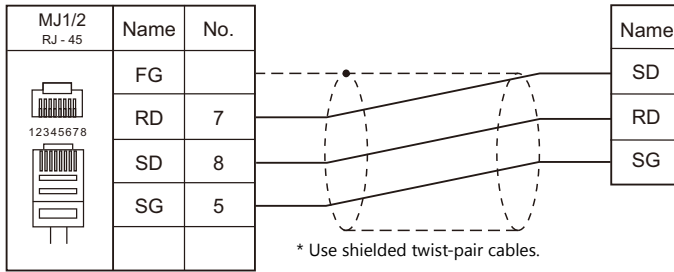

Wiring diagram 5 - M2

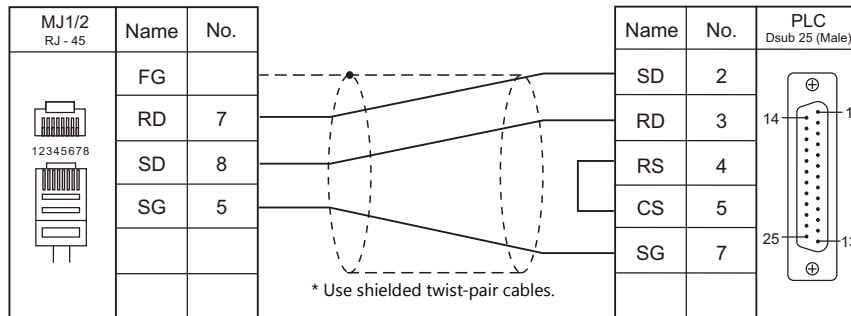

MEMO

Please use this page freely.

6. KOGANEI

6.1 Temperature Controller / Servo / Inverter

6.1 Temperature Controller / Servo / Inverter

Serial Connection

PLC Selection on the Editor	Model	Port	Signal Level	Wiring diagrams		Lst File
				CN1	MJ1/MJ2	
IBFL-TC	IBFL-TC	Connector a / b	RS-485	Wiring diagram 1 - C4	Wiring diagram 1 - M4	IBFL-TC. Lst

6.1.1 IBFL-TC

Communication Setting

Editor

Communication setting

(Underlined setting: default)

Item	Setting	Remarks
Connection Mode	1 : 1 / <u>1 : n</u> / Multi-link2 Multi-link2 (Ethernet) / 1 : n Multi-link2 (Ethernet)	
Signal Level	<u>RS-422/485</u>	
Baud Rate	<u>115200 bps</u>	
Data Length	<u>8 bits</u>	
Stop Bit	<u>1 bit</u>	
Parity	<u>Odd</u>	
Target Port No.	0 to 15	

Takt Time Controller

Specify the station number with the rotary switch.
Setting range: 0 to 15

Available Device Memory

The available setting range of device memory varies depending on the model. Be sure to set within the range available for the model to be used. Use [TYPE] when assigning indirect device memory for macro programs.

Device Memory	TYPE	Remarks
P (parameter)	00H	

PLC_CTL

Macro command "PLC_CTL F0 F1 F2"

Contents	F0	F1 (= \$u n)		F2
Writing of parameter (Flash ROM)	1 - 8 (PLC1 - 8)	n	Station number	2
		n + 1	Command: 1	
Opening adjustment *1	1 - 8 (PLC1 - 8)	n	Station number	5
		n + 1	Command: 2	
		n + 2	Port on the iB-Flow unit 1: A side 2: B side 3: Both A and B sides	
		n + 3	Pulse sending speed 10: Normally 20: When moving to home position	
Acquire operation time *3	1 - 8 (PLC1 - 8)	n + 4	Send pulse count *2 0 - 9000, -12000 (home return)	3
		n	Station number	
		n + 1	Command: 3	
Start measurement	1 - 8 (PLC1 - 8)	n + 2	Operation time to acquire 11: Operation 1 (A to B operation) 12: Operation 2 (B to A operation)	2
		n + 3	Operation time (unit: 10 msec)	
Switching offset status *4	1 - 8 (PLC1 - 8)	n	Station number	3
		n + 1	Command: 5	
		n + 2	0: Invalid 1: Valid	

Contents	F0	F1 (= \$u n)		F2
Acquire IBFL-TC status *5	1 - 8 (PLC1 - 8)	n	Station number	2
		n + 1	Command: 6	
		n + 2	IBFL-TC status 	
Version data acquisition	1 - 8 (PLC1 - 8)	n	Station number	2
		n + 1	Command: 7	
		n + 2 - n + 9	Version (16 characters) IBFL-TC Ver.x.xx	

- *1 The opening will not be changed when the iB-Flow is not connected to the takt time controller.
- *2 When "9" is specified, the opening is equivalent to 0.1%.
Do not exceed "9000" with respect to the zero position when specifying the pulse count.
- *3 The last operation time will be acquired.
Execute operation time acquisition when measurement start is executing.
- *4 Command will not be accepted if the external input (IN) port of the IBFL-TC is Low level.
If correction status is set to "Invalid", operation time measurement stops and error output (Operation time out of range) turns OFF (Within range).
- *5 If correction status is set to "Invalid", operation time measurement stops and the forth and fifth bits (Operation time out of range) turn OFF (Within range). To acquire operation time again, execute the "Start measurement" command.

6.1.2 Wiring Diagrams

When Connected at CN1:

RS-422/RS-485

Wiring diagram 1 - C4

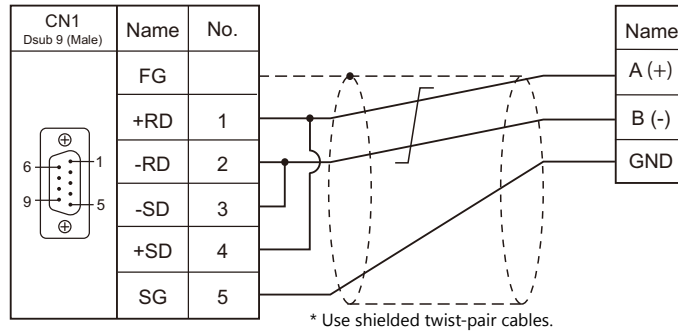

When Connected at MJ1/MJ2:

RS-422/RS-485

Wiring diagram 1 - M4

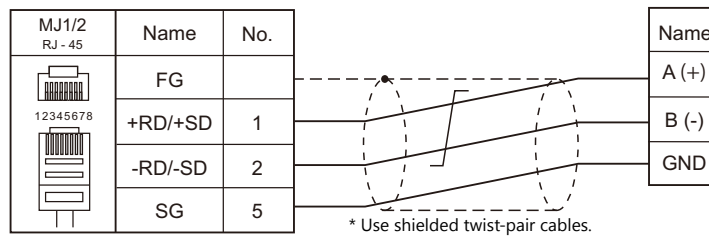

7. KOYO ELECTRONICS

7.1 PLC Connection

7.1 PLC Connection

Serial Connection

PLC Selection on the Editor	PLC	Port	Signal Level	Connection		Ladder Transfer *1
				CN1	MJ1/MJ2	
SU/SG series	SU-5	U-01DM	RS-232C	Wiring diagram 1 - C2	Wiring diagram 1 - M2	X
			RS-422	Wiring diagram 4 - C4	X	
	SU-5E SU-6B SU-6H	Universal communication port	RS-232C	Wiring diagram 1 - C2	Wiring diagram 1 - M2	
			RS-422	Wiring diagram 1 - C4	X	
		U-01DM	RS-232C	Wiring diagram 1 - C2	Wiring diagram 1 - M2	
			RS-422	Wiring diagram 4 - C4	X	
	SU-5M SU-6M	Universal communication port 1	RS-232C	Wiring diagram 1 - C2	Wiring diagram 1 - M2	
			RS-422	Wiring diagram 1 - C4	X	
		Universal communication port 2	RS-232C	Wiring diagram 3 - C2	Wiring diagram 3 - M2	
		Universal communication port 3	RS-422	Wiring diagram 2 - C4	X	
		U-01DM	RS-232C	Wiring diagram 1 - C2	Wiring diagram 1 - M2	
			RS-422	Wiring diagram 4 - C4	X	
	SZ-4	Universal communication port (PORT2)	RS-232C	Wiring diagram 3 - C2	Wiring diagram 3 - M2	
			RS-422	Wiring diagram 3 - C4	X	
	SZ-4M	Universal communication port (PORT2)	RS-232C	Wiring diagram 2 - C2	Wiring diagram 2 - M2	
			RS-422	Wiring diagram 3 - C4	X	
	SG-8	Universal communication port	RS-232C	Wiring diagram 1 - C2	Wiring diagram 1 - M2	
			RS-422	Wiring diagram 1 - C4	X	
		G-01DM (CN2)	RS-232C	Wiring diagram 1 - C2	Wiring diagram 1 - M2	
		G-01DM (CN1)	RS-422	Wiring diagram 4 - C4	X	
Wiring diagram 5 - C4	X					
PZ3	Universal communication port	RS-232C	Wiring diagram 2 - C2	Wiring diagram 2 - M2		
		RS-422	Wiring diagram 3 - C4	X		
SR-T (K protocol)	SR-1T	Universal communication port	RS-485	Wiring diagram 6 - C4	Wiring diagram 1 - M4	
SU/SG (K-Sequence)	SU-5E SU-6B	Programmer communication port	RS-232C	Wiring diagram 4 - C2	Wiring diagram 4 - M2	
		Universal communication port	RS-232C	Wiring diagram 1 - C2	Wiring diagram 1 - M2	
			RS-422	Wiring diagram 1 - C4	X	
	SU-5M SU-6M	Programmer communication port	RS-232C	Wiring diagram 4 - C2	Wiring diagram 4 - M2	
		Universal communication port 1	RS-232C	Wiring diagram 1 - C2	Wiring diagram 1 - M2	
			RS-422	Wiring diagram 1 - C4	X	
Universal communication port 2	RS-232C	Wiring diagram 3 - C2	Wiring diagram 3 - M2			
Universal communication port 3	RS-422	Wiring diagram 2 - C4	X			
SU/SG (K-Sequence)	SZ-4	Programmer communication port (PORT1)	RS-232C	Wiring diagram 3 - C2	Wiring diagram 3 - M2	
		Universal communication port (PORT2)				
	SZ-4M	Programmer communication port (PORT1)	RS-232C	Wiring diagram 2 - C2	Wiring diagram 2 - M2	
		Universal communication port (PORT2)				
SU/SG (MODBUS RTU)	SU-5M SU-6M	Universal communication port 1	RS-232C	Wiring diagram 1 - C2	Wiring diagram 1 - M2	
			RS-422	Wiring diagram 1 - C4	X	
	Universal communication port 3	RS-422	Wiring diagram 2 - C4	X		
	SZ-4M	Universal communication port (PORT2)	RS-232C	Wiring diagram 2 - C2	Wiring diagram 2 - M2	
			RS-422	Wiring diagram 3 - C4	X	

*1 For the ladder transfer function, see the V9 Series Reference Manual.

7.1.1 SU/SG

Communication Setting

Editor

Communication setting

(Underlined setting: default)

Item	Setting	Remarks
Connection Mode	<u>1:1</u> / 1 : n / Multi-link2 / Multi-link2 (Ethernet) / 1 : n Multi-link2 (Ethernet)	
Signal Level	<u>RS-232C</u> / RS-422/485	
Baud Rate	4800 / 9600 / <u>19200</u> / 38400 bps	
Data Length	8 bits	
Stop Bit	<u>1</u> / 2 bits	
Parity	None / <u>Odd</u> / Even	
Target Port No.	1 to 90	

SU-5

Host Link Module (U-01DM)

Online/offline selector switch (SW1)

SW1	Setting
 <p>Online</p> <p>Offline</p>	Online

Rotary switch (SW2, SW3)

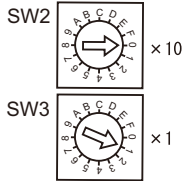
SW2, SW3	Item	Setting	Remarks
	Station number	01 to 5A (HEX)	

DIP switch (SW4)

(Underlined setting: default)

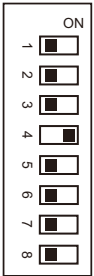
SW4	Item	Setting	Remarks																				
	No. 1 No. 2 No. 3	Baud rate	<table border="1"> <thead> <tr> <th></th> <th>No. 1</th> <th>No. 2</th> <th>No. 3</th> </tr> </thead> <tbody> <tr> <td>4800 bps</td> <td>ON</td> <td>OFF</td> <td>ON</td> </tr> <tr> <td>9600 bps</td> <td>OFF</td> <td>ON</td> <td>ON</td> </tr> <tr> <td>19200 bps</td> <td>ON</td> <td>ON</td> <td>ON</td> </tr> <tr> <td><u>38400 bps</u></td> <td>OFF</td> <td>OFF</td> <td>OFF</td> </tr> </tbody> </table>		No. 1	No. 2	No. 3	4800 bps	ON	OFF	ON	9600 bps	OFF	ON	ON	19200 bps	ON	ON	ON	<u>38400 bps</u>	OFF	OFF	OFF
		No. 1	No. 2	No. 3																			
	4800 bps	ON	OFF	ON																			
	9600 bps	OFF	ON	ON																			
19200 bps	ON	ON	ON																				
<u>38400 bps</u>	OFF	OFF	OFF																				
No. 4	Parity	OFF: <u>No parity</u> ON: Odd parity																					
No. 5	Self diagnosis	OFF: Not provided																					
No. 6 No. 7 No. 8	Response delay time	OFF: 0 ms																					

DIP switch (SW5)

(Underlined setting: default)

SW5	Item	Setting	Remarks
	No. 1	P-P setting <u>OFF</u>	
	No. 2	Master/slave setting <u>OFF: Slave</u>	
	No. 3	Time-out selection <u>OFF: Normal operation</u>	
	No. 4	ASCII/HEX selection <u>OFF: HEX</u>	

SU-5E/6B**Universal Communication Port****System parameter setting**

Set the station number, parity and data type using the system parameter setting of the programmer. For more information, refer to the PLC manual issued by the manufacturer.

(Underlined setting: default)

Item	Setting	Remarks
Parity	<u>Odd</u> / None	
Station number	<u>1</u> to 90	Valid only when DIP switch No. 2 is set to OFF
Data type	<u>HEX</u>	

The following settings are fixed; data length: 8 bits, and stop bit: 1 bit.

DIP switch

The DIP switch provided at the rear of the CPU is used to make the following settings.

(Underlined setting: default)

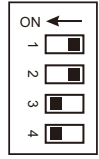
Switch	Item	Setting	Remarks									
	No. 1	Battery mode OFF: <u>Without battery</u> ON: With battery										
	No. 2	Station number setting OFF: <u>According to the system parameter setting</u> ON: Fixed to 01										
	No. 3	Baud rate	<table border="1"> <thead> <tr> <th>Baud Rate</th> <th>SW3</th> <th>SW4</th> </tr> </thead> <tbody> <tr> <td>9600 bps</td> <td>ON</td> <td>OFF</td> </tr> <tr> <td>19200 bps</td> <td>ON</td> <td>ON</td> </tr> </tbody> </table>	Baud Rate	SW3	SW4	9600 bps	ON	OFF	19200 bps	ON	ON
	Baud Rate			SW3	SW4							
9600 bps	ON	OFF										
19200 bps	ON	ON										
No. 4												

Host Link Module (U-01DM)

Settings are the same as those described in "SU-5" (page 7-2).

SU-5M/6M

Universal Communication Port 1

Set special registers "R772" and "R773", then specify "AA5A" (HEX) for the setting completion register "R767". When the set value at R767 is changed to "AAAA" (HEX), it is regarded as normal; if it is changed to "AAEA" (HEX), it is regarded as erroneous.

Parameter setting register

(Underlined setting: default)

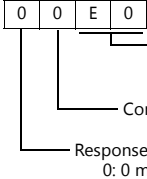
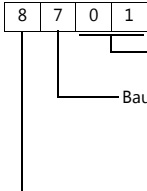
Register	Setting	Setting Example
R772	 <p>Communication protocol 4: CCM <u>E</u>: Automatic recognition (Modbus, CCM, K-Sequence)</p> <p>Communication timeout 0: 800 ms</p> <p>Response delay time 0: 0 ms</p>	00E0H CCM
R773	 <p>Station number <u>0</u>1 to 5A (HEX)</p> <p>Baud rate 4: 4800 bps <u>5</u>: 9600 bps 6: 19200 bps 7: 38400 bps</p> <p>Parity stop bit 0: Without parity, stop bit 1 2: Without parity, stop bit 2 <u>8</u>: <u>Odd parity, stop bit 1</u> A: Odd parity, stop bit 2 C: Even parity, stop bit 1 E: Even parity, stop bit 2</p>	8701H 38400 bps Odd parity Stop bit 1 Station number 01

Communication parameter settings can also be made by using the system parameter setting of the programmer. For more information, refer to the PLC manual issued by the manufacturer.

Universal Communication Port 2

Set special registers "R774" and "R775", then specify "A5AA" (HEX) for the setting completion register "R767". When the set value at R767 is changed to "AAAA" (HEX), it is regarded as normal; if it is changed to "AEAA" (HEX), it is regarded as erroneous.

Parameter setting register

Register	Setting	Setting Example
R774	Same as the setting register R772 for the universal port 1	00E0H
R775	Same as the setting register R773 for the universal port 1	8701H

Communication parameter settings can also be made by using the system parameter setting of the programmer. For more information, refer to the PLC manual issued by the manufacturer.

Universal Communication Port 3

Set special registers "R776" and "R777", then specify "5AAA" (HEX) for the setting completion register "R767". When the set value at R767 is changed to "AAAA" (HEX), it is regarded as normal; if it is changed to "EAAA" (HEX), it is regarded as erroneous.

Parameter setting register

Register	Setting	Setting Example
R776	Same as the setting register R772 for the universal port 1	00E0H
R777	Same as the setting register R773 for the universal port 1	8701H

Communication parameter settings can also be made by using the system parameter setting of the programmer. For more information, refer to the PLC manual issued by the manufacturer.

Host Link Module (U-01DM)

Settings are the same as those described in "SU-5" (page 7-2).

SU-6H

Universal Communication Port

Set special registers "R772" and "R773", then specify "AA5A" (HEX) for the setting completion register "R767". When the set value at R767 is changed to "AAAA" (HEX), it is regarded as normal; if it is changed to "AAEA" (HEX), it is regarded as erroneous.

Parameter setting register

(Underlined setting: default)

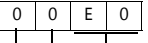
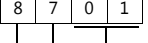
Register	Setting	Setting Example
R772	 <p>Communication protocol 4: CCM <u>E</u>: Automatic recognition (Modbus, CCM, K-Sequence)</p> <p>Communication timeout 0: 800 ms</p> <p>Response delay time 0: 0 ms</p>	00E0H CCM
R773	 <p>Station number * <u>01</u> to 5A (HEX)</p> <p>Baud rate 4: 4800 bps <u>5: 9600 bps</u> 6: 19200 bps 7: 38400 bps</p> <p>Parity stop bit 0: Without parity, stop bit 1 2: Without parity, stop bit 2 <u>8: Odd parity, stop bit 1</u> A: Odd parity, stop bit 2 C: Even parity, stop bit 1 E: Even parity, stop bit 2</p>	8701H 38400 bps Odd parity Stop bit 1 Station number 01

* Valid only when DIP switch No. 2 is set to OFF

DIP switch

The DIP switch provided at the rear of the CPU is used to make the following settings.

(Underlined setting: default)

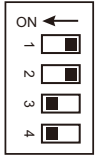
Switch	Item	Setting	Remarks
	No. 1	Battery mode	OFF: <u>Without battery</u> ON: With battery
	No. 2	Station number setting	OFF: <u>According to the parameter setting</u> ON: Fixed to 01
	No. 3 No. 4	—	Invalid

Communication parameter settings can also be made by using the system parameter setting of the programmer. For more information, refer to the PLC manual issued by the manufacturer.

Host Link Module (U-01DM)

Settings are the same as those described in "SU-5" (page 7-2).

SZ-4

Universal Communication Port (PORT2)

System parameter setting

Set the station number, parity and data type using the system parameter setting of the programmer. For more information, refer to the PLC manual issued by the manufacturer.

(Underlined setting: default)

Item	Setting	Remarks
Parity	<u>Odd</u> / None	
Station number	<u>1</u> to 90	
Data type	HEX	

The following settings are fixed; data length: 8 bits, and stop bit: 1 bit.

Parameter setting register

Set the baud rate at special register "R7632".

(Underlined setting: default)

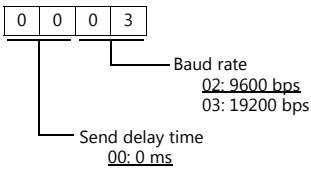
Register	Setting	Setting Example
R7632		<p>0003H</p> <p>19200 bps</p>

SZ-4M

Universal Communication Port (PORT2)

Set special registers "R7655" and "R7656", then specify "0500" (HEX) for the setting completion register "R7657". When the set value at R7657 is changed to "0A00" (HEX), it is regarded as normal; if it is changed to "0E00" (HEX), it is regarded as erroneous.

Parameter setting register

(Underlined setting: default)

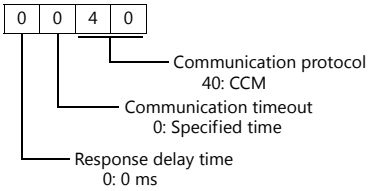
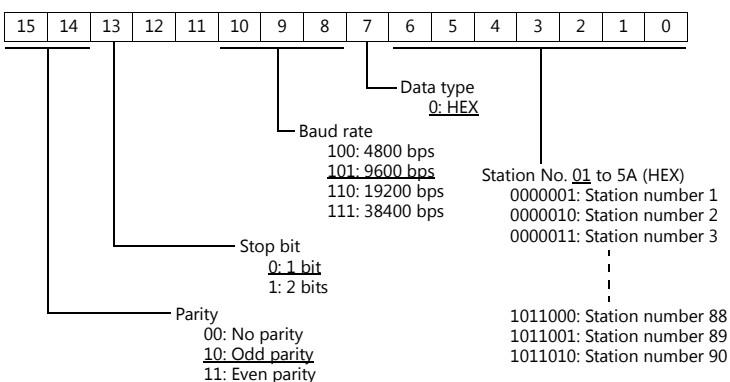
Register	Setting	Setting Example
R7655		<p>0040H</p> <p>CCM</p>
R7656		<p>8701H</p> <p>38400 bps</p> <p>Odd parity</p> <p>Stop bit 1</p> <p>Station number 01</p> <p>HEX denotation</p>

SG-8

Universal Communication Port

System parameter setting

Set the station number using the system parameter setting of the programmer. For more information, refer to the PLC manual issued by the manufacturer.

(Underlined setting: default)

Item	Setting	Remarks
Station number	<u>1</u> to 90	Valid only when DIP switch No. 2 is set to OFF
Data type	<u>HEX</u>	

The following settings are fixed; data length: 8 bits, parity: odd, and stop bit: 1 bit.

DIP switch

The DIP switch provided at the rear of the CPU is used to make the following settings.

(Underlined setting: default)

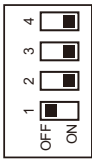
Switch	Item	Setting	Remarks									
	No. 1	Signal level OFF: <u>RS-422</u> ON: RS-232C										
	No. 2	Station number setting OFF: <u>According to the system parameter setting</u> ON: Fixed to 01										
	No. 3	Baud rate	<table border="1"> <thead> <tr> <th></th> <th>SW3</th> <th>SW4</th> </tr> </thead> <tbody> <tr> <td>9600 bps</td> <td>ON</td> <td>OFF</td> </tr> <tr> <td>19200 bps</td> <td>ON</td> <td>ON</td> </tr> </tbody> </table>		SW3	SW4	9600 bps	ON	OFF	19200 bps	ON	ON
				SW3	SW4							
9600 bps	ON	OFF										
19200 bps	ON	ON										
No. 4												

Host Link Module (G-01DM)

Online/offline selector switch

Selector Switch	Setting
	Online

DIP switch (SW1)

(Underlined setting: default)

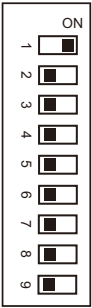
SW1	Item	Setting	Remarks																																																																
	No. 1 No. 2 No. 3 No. 4 No. 5 No. 6 No. 7	Station number setting 1 to 90 <table border="1"> <thead> <tr> <th></th> <th>1</th> <th>2</th> <th>3</th> <th>4</th> <th>5</th> <th>6</th> <th>7</th> </tr> </thead> <tbody> <tr> <td>1</td> <td>ON</td> <td>OFF</td> <td>OFF</td> <td>OFF</td> <td>OFF</td> <td>OFF</td> <td>OFF</td> </tr> <tr> <td>2</td> <td>OFF</td> <td>ON</td> <td>OFF</td> <td>OFF</td> <td>OFF</td> <td>OFF</td> <td>OFF</td> </tr> <tr> <td>3</td> <td>ON</td> <td>ON</td> <td>OFF</td> <td>OFF</td> <td>OFF</td> <td>OFF</td> <td>OFF</td> </tr> <tr> <td>:</td> <td>:</td> <td>:</td> <td>:</td> <td>:</td> <td>:</td> <td>:</td> <td>:</td> </tr> <tr> <td>88</td> <td>OFF</td> <td>OFF</td> <td>OFF</td> <td>ON</td> <td>ON</td> <td>OFF</td> <td>ON</td> </tr> <tr> <td>89</td> <td>ON</td> <td>OFF</td> <td>OFF</td> <td>ON</td> <td>ON</td> <td>OFF</td> <td>ON</td> </tr> <tr> <td>90</td> <td>OFF</td> <td>ON</td> <td>OFF</td> <td>ON</td> <td>ON</td> <td>OFF</td> <td>ON</td> </tr> </tbody> </table>		1	2	3	4	5	6	7	1	ON	OFF	OFF	OFF	OFF	OFF	OFF	2	OFF	ON	OFF	OFF	OFF	OFF	OFF	3	ON	ON	OFF	OFF	OFF	OFF	OFF	:	:	:	:	:	:	:	:	88	OFF	OFF	OFF	ON	ON	OFF	ON	89	ON	OFF	OFF	ON	ON	OFF	ON	90	OFF	ON	OFF	ON	ON	OFF	ON	For more information on any station number settings other than those given on the left, refer to the PLC manual issued by the manufacturer.
		1	2	3	4	5	6	7																																																											
	1	ON	OFF	OFF	OFF	OFF	OFF	OFF																																																											
2	OFF	ON	OFF	OFF	OFF	OFF	OFF																																																												
3	ON	ON	OFF	OFF	OFF	OFF	OFF																																																												
:	:	:	:	:	:	:	:																																																												
88	OFF	OFF	OFF	ON	ON	OFF	ON																																																												
89	ON	OFF	OFF	ON	ON	OFF	ON																																																												
90	OFF	ON	OFF	ON	ON	OFF	ON																																																												
No. 8	P-P setting	OFF																																																																	
No. 9	Master/slave setting	OFF: Slave																																																																	

DIP switch (SW2)

(Underlined setting: default)

SW2		Item	Setting	Remarks																
	No. 1 No. 2 No. 3	Baud rate	<table border="1"> <thead> <tr> <th></th> <th>SW1</th> <th>SW2</th> <th>SW3</th> </tr> </thead> <tbody> <tr> <td>4800 bps</td> <td>ON</td> <td>OFF</td> <td>ON</td> </tr> <tr> <td>9600 bps</td> <td>OFF</td> <td>ON</td> <td>ON</td> </tr> <tr> <td>19200 bps</td> <td>ON</td> <td>ON</td> <td>ON</td> </tr> </tbody> </table>		SW1	SW2	SW3	4800 bps	ON	OFF	ON	9600 bps	OFF	ON	ON	19200 bps	ON	ON	ON	
		SW1	SW2	SW3																
	4800 bps	ON	OFF	ON																
	9600 bps	OFF	ON	ON																
	19200 bps	ON	ON	ON																
	No. 4	Parity	OFF: No parity ON: Odd parity																	
	No. 5	Self diagnosis	OFF: Not provided																	
	No. 6	Turnaround delay	OFF: Not provided																	
	No. 7 No. 8	Response delay time	OFF: 0 ms																	
No. 9	ASCII/HEX selection	OFF: HEX																		

Short plug 1

Short plug 1 is used to short-circuit the FG (frame ground) and 0-V power for the communication system.

Plug	Setting	Remarks
	G side: Not short-circuited FG side: Short-circuited	

Short plug 2

Short plug 2 is used to switch the signal level of the CH2 port.

Plug	Setting	Remarks
	RS-232C ENABLE: RS-232C RS-232C DISABLE: RS-422	

PZ3**Universal Communication Port**

Settings are the same as those described in "SZ-4" (page 7-6).

Available Device Memory

The available setting range of device memory varies depending on the PLC model. Be sure to set within the range available for the PLC to be used. Use [TYPE] when assigning indirect device memory for macro programs.

Device Memory	TYPE	Remarks
R (data register)	00H	
I (input)	01H	
Q (output)	02H	
M (internal relay)	03H	
S (stage)	04H	
GI (link input)	05H	
GQ (link output)	06H	
T (timer/contact)	07H	
C (counter/contact)	08H	

7.1.2 SR-T (K Protocol)

Communication Setting

Editor

Communication setting

(Underlined setting: default)

Item	Setting	Remarks
Connection Mode	<u>1:1</u> / Multi-link2 / Multi-link2 (Ethernet)	
Signal Level	<u>RS-422/485</u>	
Baud Rate	<u>19200</u>	
Data Length	<u>8 bits</u>	
Stop Bit	<u>1 bit</u>	
Parity	<u>Odd</u>	
Target Port No.	0 to 31	

PLC

Universal Communication Port

No particular setting is necessary on the PLC. The PLC always performs communication functions using the following parameters. Set the following parameters under [Communication Setting] of the editor.

Item	Setting	Remarks
Baud rate	<u>19200 bps</u>	
Parity	<u>Odd</u>	
Data length	<u>8 bits</u>	
Stop bit	<u>1 bit</u>	
Data type	<u>HEX</u>	

Calendar

This model is not equipped with the calendar function. Use the built-in clock of the V series.

Available Device Memory

The available setting range of device memory varies depending on the PLC model. Be sure to set within the range available for the PLC to be used. Use [TYPE] when assigning indirect device memory for macro programs.

Device Memory	TYPE	Remarks
D (word device)	00H	
X (input)	01H	Common to X and Y
Y (output)	02H	Common to X and Y
M (internal relay)	03H	
S (stage)	04H	
K (keep relay)	05H	
L (link relay)	06H	
T (timer/contact)	07H	
C (counter/contact)	08H	

7.1.3 SU/SG (K-Sequence)

Communication Setting

Editor

Communication setting

(Underlined setting: default)

Item	Setting	Remarks
Connection Mode	<u>1</u> :1 / Multi-link2 / Multi-link2 (Ethernet)	
Signal Level	<u>RS-232C</u> / RS-422/485	
Baud Rate	4800 / 9600 / <u>19200</u> / 38400 bps	
Data Length	8 bits	
Stop Bit	<u>1</u> / 2 bits	
Parity	None / <u>Odd</u> / Even	
Target Port No.	0 to 31	

SU-5M/6M

Programmer Communication Port

No particular setting is necessary on the PLC. The PLC always performs communication functions using the following parameters. Set the following parameters under [Communication Setting] of the editor.

Item	Setting	
Baud Rate	9600 bps	
Parity	Odd	
Data Length	8	
Stop Bit	1	
Data Type	HEX	

Universal Communication Port 1

Set parameters into the special register "R772, 773", then set "AA5A" (HEX) into the setting complete register "R767". When the set value at R767 is changed to "AAAA" (HEX), it is regarded as normal; if it is changed to "AAEA" (HEX), it is regarded as erroneous.

Parameter setting register

(Underlined setting: default)

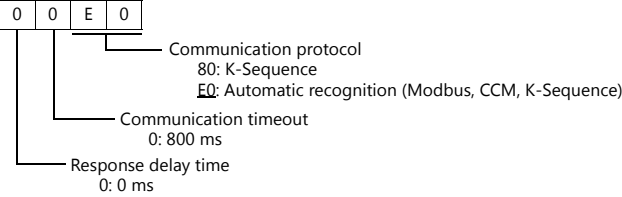
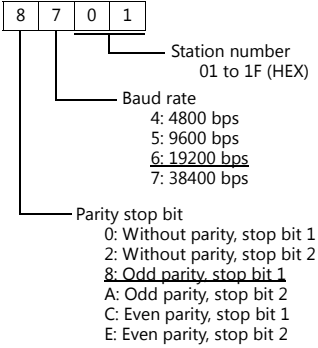
Register	Setting	Setting Example
R772	 <p>0 0 <u>E</u> 0</p> <p>Communication protocol 80: K-Sequence <u>E0</u>: Automatic recognition (Modbus, CCM, K-Sequence)</p> <p>Communication timeout 0: 800 ms</p> <p>Response delay time 0: 0 ms</p>	00E0H K-Sequence
R773	 <p>8 7 0 1</p> <p>Station number 01 to 1F (HEX)</p> <p>Baud rate 4: 4800 bps 5: 9600 bps <u>6: 19200 bps</u> 7: 38400 bps</p> <p>Parity stop bit 0: Without parity, stop bit 1 2: Without parity, stop bit 2 <u>8: Odd parity, stop bit 1</u> A: Odd parity, stop bit 2 C: Even parity, stop bit 1 E: Even parity, stop bit 2</p>	8701H 38400 bps Odd parity Stop bit 1 Station number 01

Communication parameter settings can also be made by using the system parameter setting of the programmer. For more information, refer to the PLC manual issued by the manufacturer.

Universal Communication Port 2

Set parameters into the special register "R774, 775", then set "A5AA" (HEX) into the setting complete register "R767". When the set value at R767 is changed to "AAAA" (HEX), it is regarded as normal; if it is changed to "AEAA" (HEX), it is regarded as erroneous.

Parameter setting register

Register	Setting	Setting Example
R774	Same as the setting register R772 for the universal port 1	00E0H
R775	Same as the setting register R773 for the universal port 1	8701H

Communication parameter settings can also be made by using the system parameter setting of the programmer. For more information, refer to the PLC manual issued by the manufacturer.

Universal Communication Port 3

Set parameters into the special register "R776, 777", then set "5AAA" (HEX) into the setting complete register "R767". When the set value at R767 is changed to "AAAA" (HEX), it is regarded as normal; if it is changed to "EAAA" (HEX), it is regarded as erroneous.

Parameter setting register

Register	Setting	Setting Example
R776	Same as the setting register R772 for the universal port 1	00E0H
R777	Same as the setting register R773 for the universal port 1	8701H

Communication parameter settings can also be made by using the system parameter setting of the programmer. For more information, refer to the PLC manual issued by the manufacturer.

SZ-4/SZ-4M**Programmer Communication Port (PORT1) / Universal Communication Port (PORT2)**

No particular setting is necessary on the PLC. The PLC performs communication functions using the following parameters. Set the following parameters under [Communication Setting] of V9.

Item	Setting	Remarks
Baud Rate	9600 bps	For PORT2: 19200 bps can be set in the special register.
Parity	Odd	
Data Length	8	
Stop Bit	1	
Data Type	HEX	

Available Device Memory

The available setting range of device memory varies depending on the PLC model. Be sure to set within the range available for the PLC to be used. Use [TYPE] when assigning indirect device memory for macro programs.

Device Memory	TYPE	Remarks
R (data register)	00H	
I (input)	01H	
Q (output)	02H	
M (internal relay)	03H	
S (stage)	04H	
GI (link input)	05H	
GQ (link output)	06H	
T (timer/contact)	07H	
C (counter/contact)	08H	

7.1.4 SU/SG (MODBUS RTU)

Communication Setting

Editor

Communication setting

(Underlined setting: default)

Item	Setting	Remarks
Connection Mode	<u>1</u> : 1 / 1 : n / Multi-link2 / Multi-link2 (Ethernet) / 1 : n Multi-link2 (Ethernet)	
Signal Level	<u>RS-232C</u> / RS-422/485	
Baud Rate	4800 / 9600 / <u>19200</u> / 38400 bps	
Data Length	8 bits	
Stop Bit	<u>1</u> / 2 bits	
Parity	None / <u>Odd</u> / Even	
Target Port No.	0 to 90	

SU-5M/6M

Universal Communication Port 1

Set parameters into the special register "R772, 773", then set "AA5A" (HEX) into the setting complete register "R767". When the set value at R767 is changed to "AAAA" (HEX), it is regarded as normal; if it is changed to "AAEA" (HEX), it is regarded as erroneous.

Parameter setting register

(Underlined setting: default)

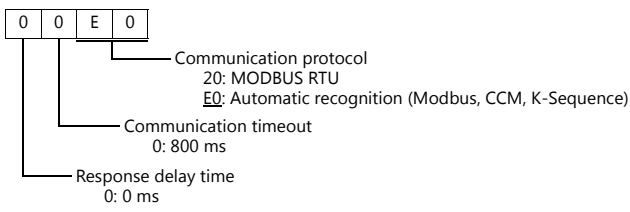
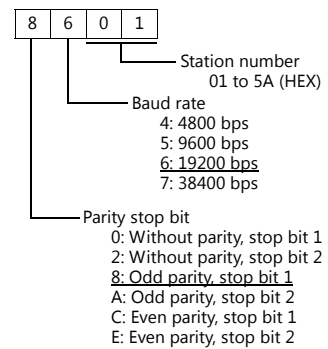
Register	Setting	Setting Example
R772	 <p>0 0 E 0</p> <ul style="list-style-type: none"> Communication protocol 0: MODBUS RTU E0: Automatic recognition (Modbus, CCM, K-Sequence) Communication timeout 0: 800 ms Response delay time 0: 0 ms 	00E0H
R773	 <p>8 6 0 1</p> <ul style="list-style-type: none"> Station number 01 to 5A (HEX) Baud rate 4: 4800 bps 5: 9600 bps <u>6: 19200 bps</u> 7: 38400 bps Parity stop bit 0: Without parity, stop bit 1 2: Without parity, stop bit 2 <u>8: Odd parity, stop bit 1</u> A: Odd parity, stop bit 2 C: Even parity, stop bit 1 E: Even parity, stop bit 2 	8701H 38400 bps Odd parity Stop bit 1 Station number 01

Communication parameter settings can also be made by using the system parameter setting of the programmer. For more information, refer to the PLC manual issued by the manufacturer.

Universal Communication Port 3

Set parameters into the special register "R776, 777", then set "5AAA" (HEX) into the setting complete register "R767". When the set value at R767 is changed to "AAAA" (HEX), it is regarded as normal; if it is changed to "EAAA" (HEX), it is regarded as erroneous.

Parameter setting register

Register	Setting	Setting Example
R776	Same as the setting register R772 for the universal port 1	00E0H
R777	Same as the setting register R773 for the universal port 1	8701H

Communication parameter settings can also be made by using the system parameter setting of the programmer. For more information, refer to the PLC manual issued by the manufacturer.

SZ-4M

Universal Communication Port (PORT2)

Set parameters into the special register "R7655, 7656", then set "0500" (HEX) into the setting complete register "R7657". When the set value at R7657 is changed to "0A00" (HEX), it is regarded as normal; if it is changed to "0E00" (HEX), it is regarded as erroneous.

Parameter setting register

(Underlined setting: default)

Register	Setting	Setting Example
R7655	<p>0 0 2 0</p> <p>Communication protocol 20: MODBUS RTU</p> <p>Communication timeout 0: Specified time</p> <p>Response delay time 0: 0 ms</p>	0020H
R7656	<p>Bit 15 14 13 12 11 10 9 8 7 6 5 4 3 2 1 0</p> <p>Parity 00: No parity <u>10: Odd parity</u> 11: Even parity</p> <p>Stop bit 0: 1 bit 1: 2 bits</p> <p>Baud rate 100: 4800 bps <u>101: 9600 bps</u> 110: 19200 bps 111: 38400 bps</p> <p>Data type 0: <u>HEX</u></p> <p>Station No. 01 to 5A (HEX) 0000001: Station number 1 0000010: Station number 2 0000011: Station number 3 ⋮ 1011000: Station number 88 1011001: Station number 89 1011010: Station number 90</p>	8701H 38400 bps Odd parity Stop bit 1 Station number 01 HEX denotation

Communication parameter settings can also be made by using the system parameter setting of the programmer. For more information, refer to the PLC manual issued by the manufacturer.

Available Device Memory

The available setting range of device memory varies depending on the PLC model. Be sure to set within the range available for the PLC to be used. Use [TYPE] when assigning indirect device memory for macro programs.

Device Memory	TYPE	Remarks
R (data register)	00H	
I (input)	01H	
Q (output)	02H	
M (internal relay)	03H	
S (stage)	04H	
GI (link input)	05H	
GQ (link output)	06H	
T (timer/contact)	07H	
C (counter/contact)	08H	

7.1.5 Wiring Diagrams

When Connected at CN1:

RS-232C

Wiring diagram 1 - C2

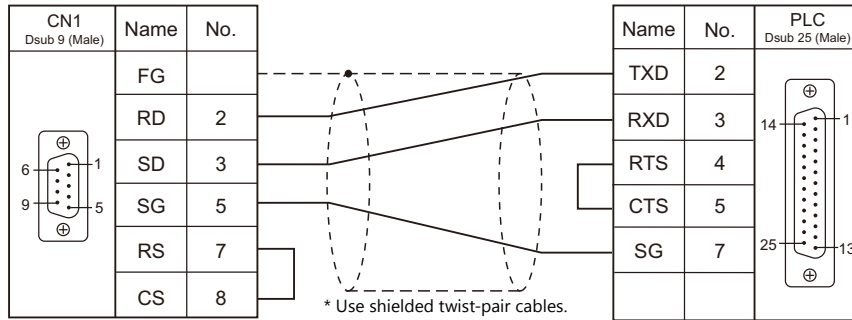

Wiring diagram 2 - C2

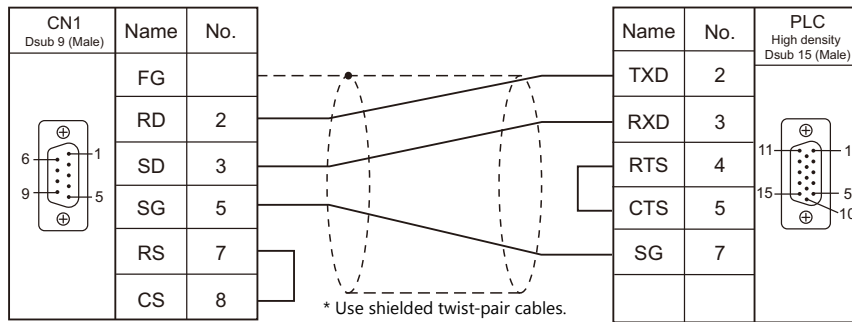

Wiring diagram 3 - C2

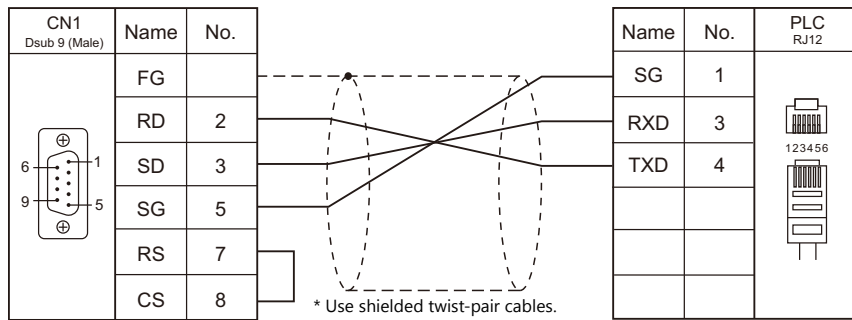

Wiring diagram 4 - C2

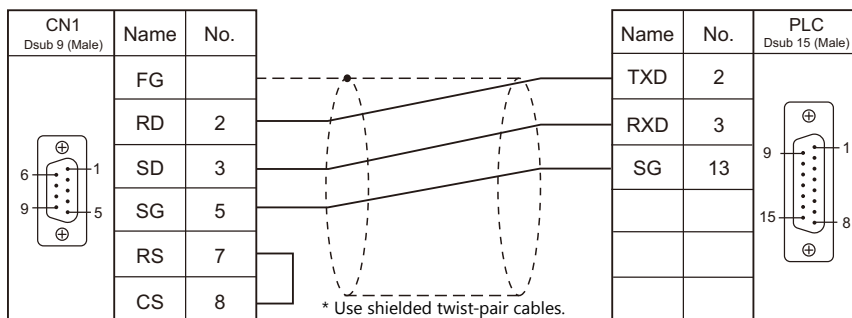

RS-422/RS-485

Wiring diagram 1 - C4

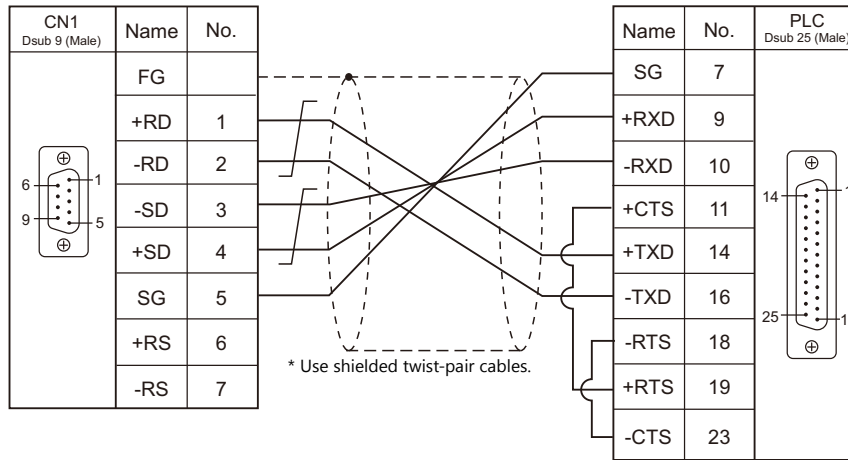

Wiring diagram 2 - C4

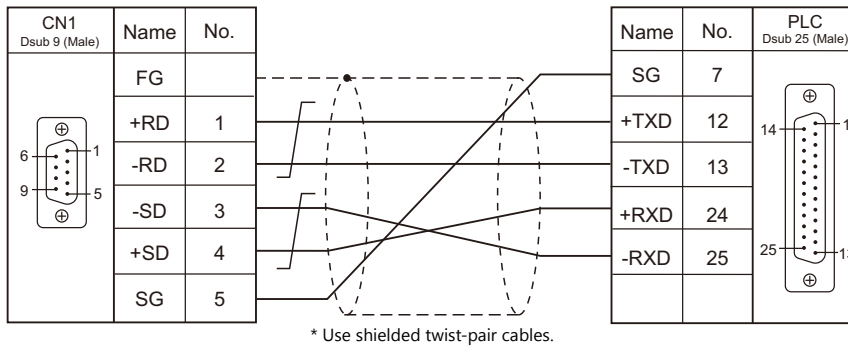

* SU-6M: Terminal block connectable

Wiring diagram 3 - C4

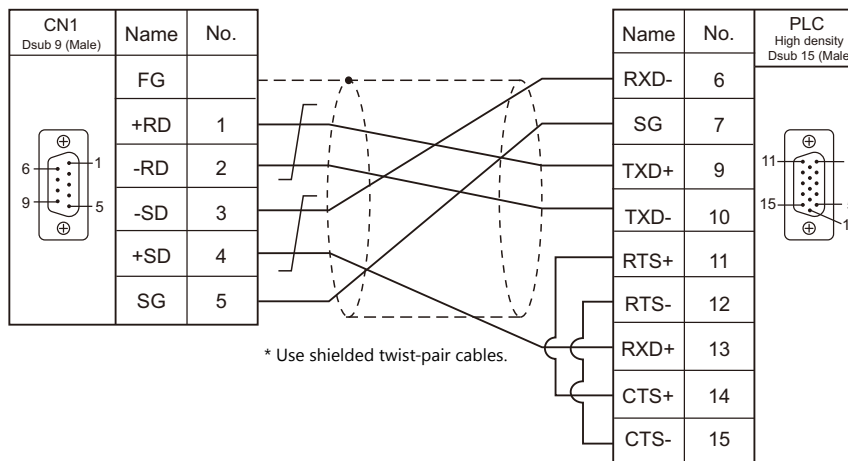

Wiring diagram 4 - C4

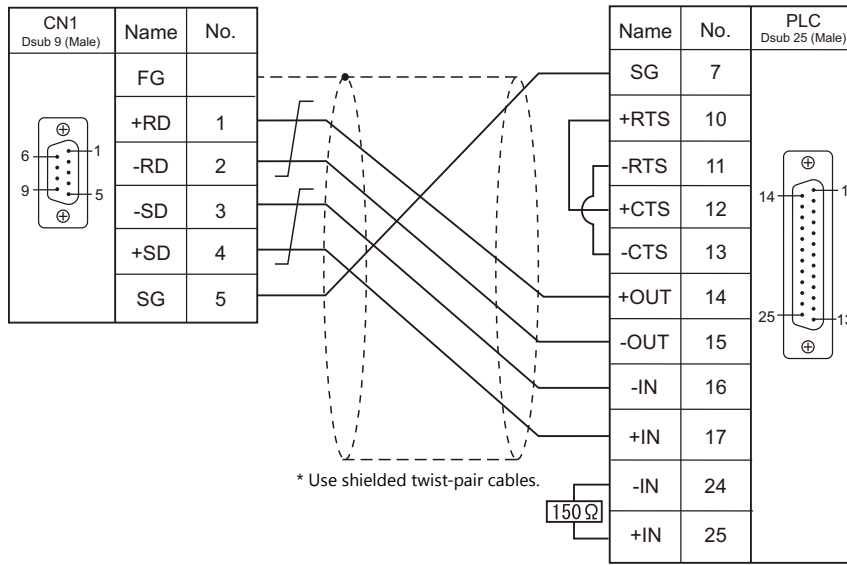

Wiring diagram 5 - C4

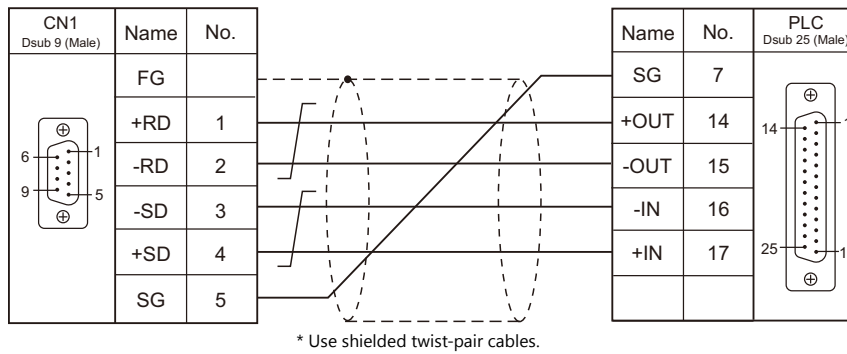

Wiring diagram 6 - C4

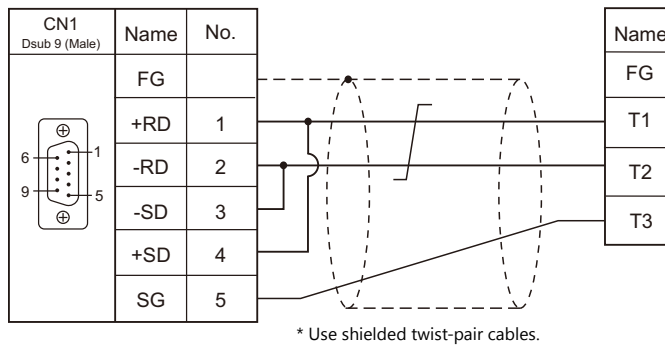

When Connected at MJ1/MJ2:

RS-232C

Wiring diagram 1 - M2

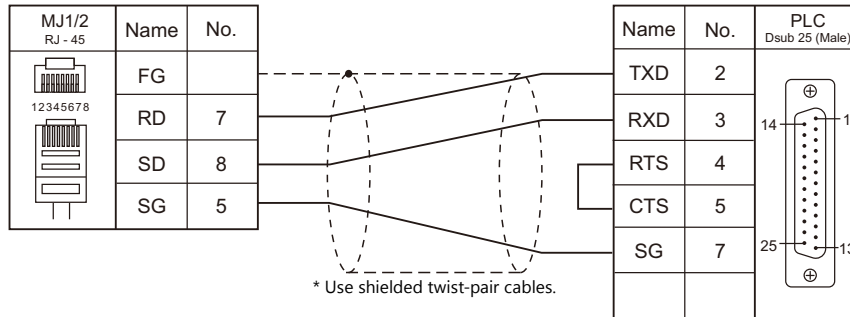

Wiring diagram 2 - M2

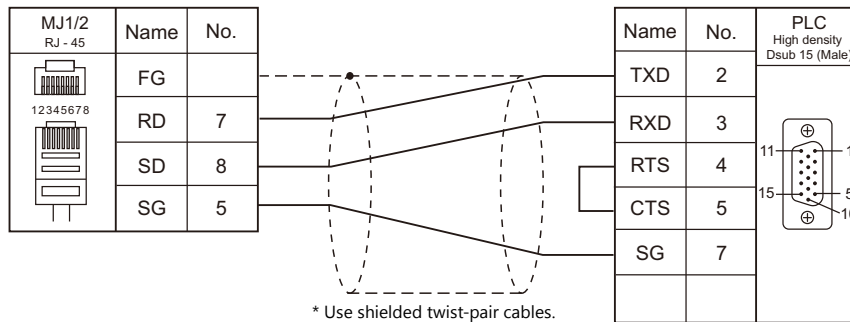

Wiring diagram 3 - M2

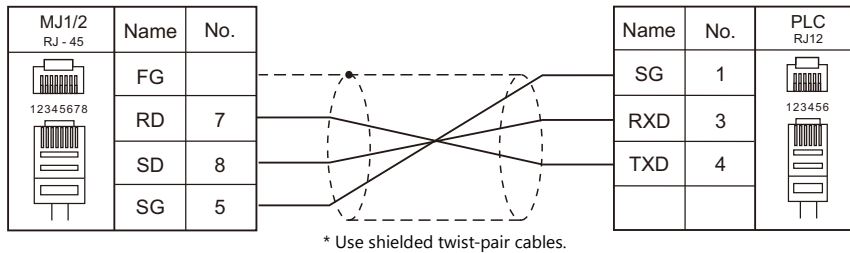

Wiring diagram 4 - M2

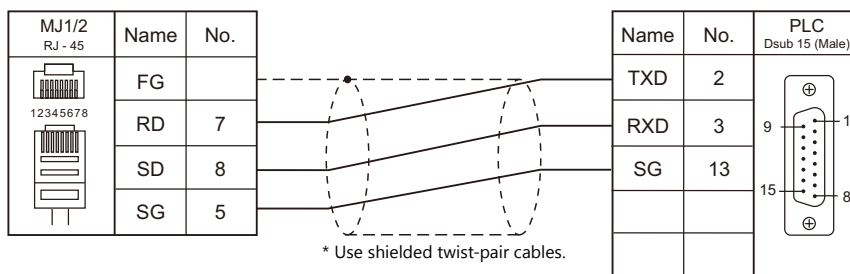

RS-422/RS-485

Wiring diagram 1 - M4

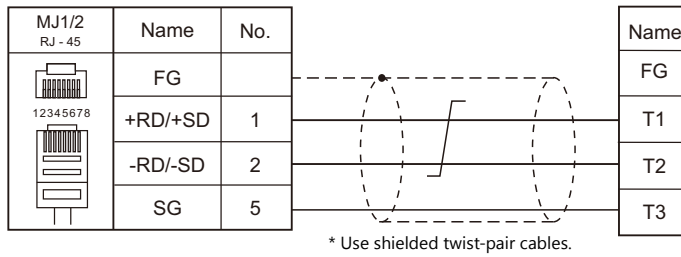

8. LS

8.1 PLC Connection

8.1 PLC Connection

Serial Connection

PLC Selection on the Editor	CPU		Unit/Port	Signal Level	Connection		Ladder Transfer *1
					CN1	MJ1/MJ2	
MASTER-KxxxS	K200S	K3P-07AS	RS-232C port on the CPU unit	RS-232C	Wiring diagram 1 - C2	Wiring diagram 1 - M2	×
		K3P-07CS					
	K300S	K4P-15AS					
	K1000S	K7P-30AS					
MASTER-KxxxS CNET	K200S	K3P-07AS K3P-07BS K3P-07CS	K3F-CU2A	RS-232C	Wiring diagram 2 - C2	Wiring diagram 2 - M2	
			K3F-CU4A	RS-422/485	Wiring diagram 1 - C4	Wiring diagram 1 - M4	
	K300S	K4P-15AS	K4F-CUEA	RS-232C	Wiring diagram 2 - C2	Wiring diagram 2 - M2	
				RS-422/485	Wiring diagram 1 - C4	Wiring diagram 1 - M4	
	K1000S	K7P-30AS	K7F-CUEA	RS-232C	Wiring diagram 2 - C2	Wiring diagram 2 - M2	
				RS-422/485	Wiring diagram 1 - C4	Wiring diagram 1 - M4	
	GLOFA CNET	GM6	GM6-CPUA GM6-CPUB GM6-CPUC	G6L-CUEB	RS-232C	Wiring diagram 2 - C2	Wiring diagram 2 - M2
				G6L-CUEC	RS-422/485	Wiring diagram 1 - C4	Wiring diagram 1 - M4
GM4		GM4-CPUA	G4L-CUEA	RS-232C	Wiring diagram 2 - C2	Wiring diagram 2 - M2	
				RS-422/485	Wiring diagram 1 - C4	Wiring diagram 1 - M4	
GM3		GM3-CPUA	G3L-CUEA	RS-232C	Wiring diagram 2 - C2	Wiring diagram 2 - M2	
				RS-422/485	Wiring diagram 1 - C4	Wiring diagram 1 - M4	
GLOFA GM7 CNET	GM7	G7M-DR G7M-DT	G7L-CUEB	RS-232C	Wiring diagram 1 - C2	Wiring diagram 1 - M2	
			G7L-CUEC	RS-422/485	Wiring diagram 1 - C4	Wiring diagram 1 - M4	
GLOFA GM series CPU	GM6	GM6-CPUA GM6-CPUB GM6-CPUC	RS-232C port on the CPU unit	RS-232C	Wiring diagram 1 - C2	Wiring diagram 1 - M2	
							GM4
	GM3	GM3-CPUA					
							GM7
XGT/XGK series CNET	XGK-CPUH XGK-CPUA XGK-CPUS XGK-CPUE		XGL-C22A	RS-232C	Wiring diagram 1 - C2	Wiring diagram 1 - M2	
			XGL-CH2A	RS-232C			
			XGL-C42A	RS-422	Wiring diagram 2 - C4	Wiring diagram 2 - M4	
XGT/XGK series CPU	XGK-CPUH XGK-CPUA XGK-CPUS XGK-CPUE		RS-232C port on the CPU unit	RS-232C	Wiring diagram 1 - C2	Wiring diagram 1 - M2	
XGT/XGI series CNET	XGI-CPUH XGI-CPUU XGI-CPUS		XGL-C22A	RS-232C	Wiring diagram 1 - C2	Wiring diagram 1 - M2	
			XGL-CH2A	RS-232C			
			XGL-C42A	RS-422	Wiring diagram 2 - C4	Wiring diagram 2 - M4	
XGT/XGI series CPU	XGI-CPUH XGI-CPUU XGI-CPUS		RS-232C port on the CPU unit	RS-232C	Wiring diagram 1 - C2	Wiring diagram 1 - M2	

*1 For the ladder transfer function, see the V9 Series Reference Manual.

Ethernet Connection

PLC Selection on the Editor	CPU	Unit	TCP/IP	UDP/IP	Port No.	Keep Alive *1	Ladder Transfer *2
GLOFA GM series (Ethernet UDP/IP)	GM6	G6L-EUTB	×	○	2005 fixed	○	×
XGT/XGK series (Ethernet)	XGK-CPUH XGK-CPUA XGK-CPUS XGK-CPUE XGK-CPUU	XGL-EFMT	○	○	TCP/IP: 2004 fixed (Max. 16 units)		
					UDP/IP: 2005 fixed		
XGT/XGI series (Ethernet)	XGI-CPUH XGI-CPUU XGI-CPUS	XGL-EFMT	○	○	TCP/IP: 2004 fixed (Max. 16 units)		
					UDP/IP: 2005 fixed		

*1 For KeepAlive functions, see "1.3.2 Ethernet Communication".

*2 For the ladder transfer function, see the V9 Series Reference Manual.

8.1.1 MASTER-KxxxS

Communication Setting

Editor

Communication setting

(Underlined setting: default)

Item	Setting	Remarks
Connection Mode	<u>1</u> :1 / Multi-link2 / Multi-link2 (Ethernet)	
Signal Level	<u>RS-232C</u>	
Baud Rate	9600 / 19200 / <u>38400</u> / 57600 / 76800 / 115200 bps	
Data Length	<u>8</u> bits	
Stop Bit	<u>1</u> bit	
Parity	<u>None</u>	

PLC

No particular setting is necessary on the PLC.

Calendar

Although this model is equipped with the calendar function, the V series cannot read and write to the calendar. Use the built-in clock of the V series.

Available Device Memory

The available setting range of device memory varies depending on the PLC model. Be sure to set within the range available for the PLC to be used. Use [TYPE] when assigning indirect device memory for macro programs.

Device Memory	TYPE	Remarks
P (input/output relay)	00H	Input relay; read only
M (auxiliary relay)	01H	
L (link relay)	02H	
K (keep relay)	03H	
F (special relay)	04H	Read only
T (timer/current value)	05H	
C (counter/current value)	06H	
D (data register)	07H	
TC (timer/contact)	09H	
CC (counter/contact)	0AH	

8.1.2 MASTER-KxxxS CNET

Communication Setting

Editor

Communication setting

(Underlined setting: default)

Item	Setting	Remarks
Connection Mode	<u>1:1</u> / 1 : n / Multi-link2 / Multi-link2 (Ethernet) / 1 : n Multi-link2 (Ethernet)	
Signal Level	<u>RS-232C</u> / RS-422/485	
Baud Rate	9600 / 19200 / <u>38400</u> / 57600 / 76800 / 115200 bps	
Data Length	7 / <u>8</u> bits	
Stop Bit	<u>1</u> / 2 bits	
Parity	<u>None</u> / Odd / Even	
Target Port No.	<u>0</u> to 31	

PLC

MODE switch

MODE Switch	Operation Mode	Remarks
 K3F-CU2A K3F-CU4A	1: Dedicated	Stand-alone mode
	RS-232C 3, 5: Dedicated RS-422 3, 4, 7: Dedicated	

KGL_WIN for Windows

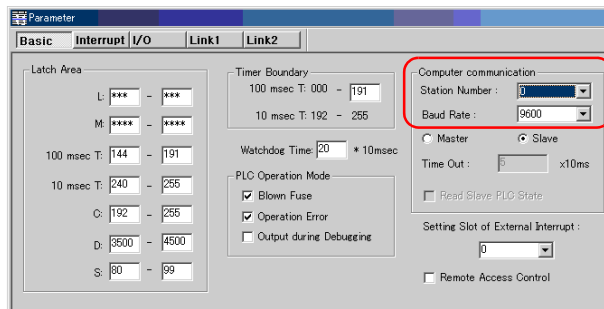

(Underlined setting: default)

Item	Setting	Remarks
Station Number	<u>0</u> to 31	
Baud Rate	9600 / 19200 / <u>38400</u> bps	

Cnet Frame Editor

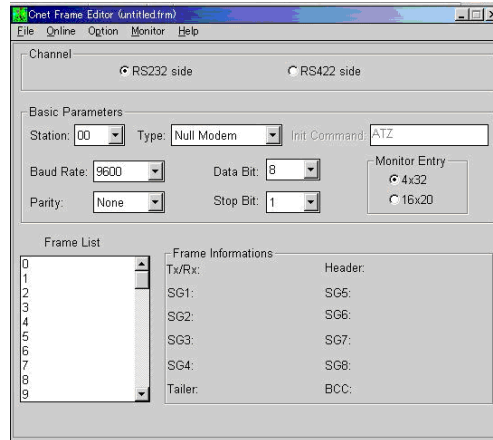

(Underlined setting: default)

Item	Setting	Remarks
Channel	<u>RS232C</u> / RS422	
Baud Rate	9600 / 19200 / <u>38400</u> / 76800 bps	76800: Valid only when [Channel: RS422 side] is selected
Data Bit	7 / <u>8</u> bits	
Stop Bit	<u>1</u> / 2 bits	
Parity	<u>None</u> / Odd / Even	
Station	<u>0</u> to 31	
Type	<u>RS422</u> / RS485	To be set only when [Channel: RS422 side] is selected

Available Device Memory

The available setting range of device memory varies depending on the PLC model. Be sure to set within the range available for the PLC to be used. Use [TYPE] when assigning indirect device memory for macro programs.

Device Memory	TYPE	Remarks
P (input/output relay)	00H	PW as word device, input relay: read only
M (auxiliary relay)	01H	MW as word device
L (link relay)	02H	LW as word device
K (keep relay)	03H	KW as word device
F (special relay)	04H	FW as word device, read only
T (timer/current value)	05H	
C (counter/current value)	06H	
D (data register)	07H	
TC (timer/contact)	09H	
CC (counter/contact)	0AH	

8.1.3 GLOFA CNET

Communication Setting

Editor

Communication setting

(Underlined setting: default)

Item	Setting	Remarks
Connection Mode	<u>1:1</u> / 1 : n / Multi-link2 / Multi-link2 (Ethernet) / 1 : n Multi-link2 (Ethernet)	
Signal Level	<u>RS-232C</u> / RS-422/485	
Baud Rate	9600 / 19200 / <u>38400</u> / 57600 / 76800 bps	
Data Length	7 / <u>8</u> bits	
Stop Bit	<u>1</u> / 2 bits	
Parity	<u>None</u> / Odd / Even	
Target Port No.	<u>0</u> to 31	

PLC

Cnet frame editor

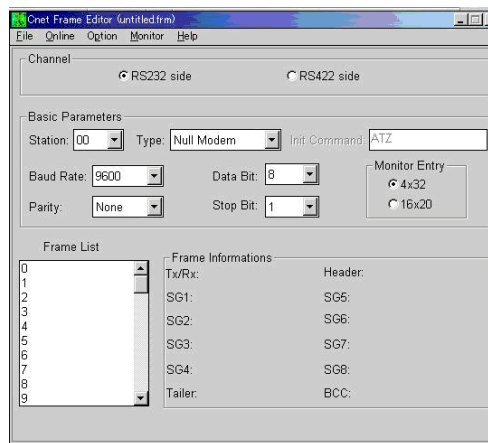

(Underlined setting: default)

Item	Setting	Remarks
Channel	<u>RS232C</u> / RS422	
Baud Rate	9600 / 19200 / <u>38400</u> / 76800 bps	76800: Valid only when [Channel: RS422 side] is selected
Data Bit	7 / <u>8</u> bits	
Stop Bit	<u>1</u> / 2 bits	
Parity	<u>None</u> / Odd / Even	
Station	<u>0</u> to 31	
Type	<u>RS422</u> / RS485	To be set only when [Channel: RS422 side] is selected

Calendar

This model is not equipped with the calendar function. Use the built-in clock of the V series.

Available Device Memory

The available setting range of device memory varies depending on the PLC model. Be sure to set within the range available for the PLC to be used. Use [TYPE] when assigning indirect device memory for macro programs.

Device Memory	TYPE	Remarks
M (internal memory)	00H	MW as word device
Q (output)	01H	QW as word device *1
I (input)	02H	IW as word device *1

*1 The assigned device memory is expressed as shown on the right when editing the screen.

Example: Q 0 . 0 . 0

Address
Period
Slot No.
Period
Base No.

Indirect Device Memory Designation

	15	8	7	0
n+0	Model		Device type	
n+1	Address No.			
n+2	Expansion code		Bit designation	
n+3	00		Station number	

- Using Q or I device memory

- Word access

QW1.7.3

C (Address)
B (Slot No.)
A (Base No.)

$$\text{Address number} = A \times 32 + B \times 4 + C = 1 \times 32 + 7 \times 4 + 3 = 63$$

Specify "63" (DEC) for the address number.

- Bit access

QW1.7.63

C (Address)
B (Slot No.)
A (Base No.)

$$\begin{aligned} \text{Address number} &= A \times 32 + B \times 4 + (\text{quotient of } C \text{ divided by } 16) \\ &= 1 \times 32 + 7 \times 4 + (63 \div 16) = 63 \end{aligned}$$

$$\text{Bit designation} = \text{remainder when } C \text{ is divided by } 16 = (63 \div 16) = 15$$

Specify "63" (DEC) for the address number, and "15" (DEC) for the bit designation.

8.1.4 GLOFA GM7 CNET

Communication Setting

Editor

Communication setting

(Underlined setting: default)

Item	Setting	Remarks
Connection Mode	<u>1:1</u> / 1 : n / Multi-link2 / Multi-link2 (Ethernet) / 1 : n Multi-link2 (Ethernet)	
Signal Level	<u>RS-232C</u> / RS-422/485	
Baud Rate	4800 / 9600 / <u>19200</u> / 38400 / 57600 bps	
Data Length	7 / <u>8</u> bits	
Stop Bit	<u>1</u> / 2 bits	
Parity	<u>None</u> / Odd / Even	
Target Port No.	<u>0</u> to 31	

PLC

Mode switches

TM/TC MODE	Setting	Remarks
G7L-CUEB 	BUILT IN CNET	OFF
	ROM MODE	OFF/ON

* G7L-CUEC is not provided with mode switches.

Communication Channel 0

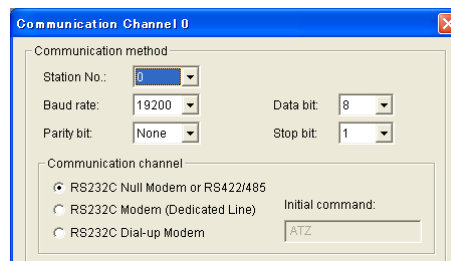

(Underlined setting: default)

Item	Setting	Remarks
Station No.	<u>0</u> to 31	
Baud rate	4800 / 9600 / <u>19200</u> / 38400 / 57600 bps	
Data bit	7 / <u>8</u> bits	
Parity bit	<u>None</u> / Odd / Even	
Stop bit	<u>1</u> / 2 bits	

Calendar

This model is not equipped with the calendar function. Use the built-in clock of the V series.

Available Device Memory

The contents of "Available Device Memory" are the same as those described in "8.1.3 GLOFA CNET".

8.1.5 GLOFA GM Series CPU

Communication Setting

Editor

Communication setting

(Underlined setting: default)

Item	Setting	Remarks
Connection Mode	<u>1</u> :1 / Multi-link2 / Multi-link2 (Ethernet)	
Signal Level	<u>RS-232C</u> / RS-422/485	
Baud Rate	<u>38400</u> bps	
Data Length	<u>8</u> bits	
Stop Bit	<u>1</u> bit	
Parity	<u>None</u>	
Target Port No.	<u>0</u> to 31	

PLC

No particular setting is necessary on the PLC.

The following settings are fixed; baud rate: 38400 bps, data length: 8 bits, without parity, and stop bit: 1 bit.

Calendar

This model is not equipped with the calendar function. Use the built-in clock of the V series.

Available Device Memory

The contents of "Available Device Memory" are the same as those described in "8.1.3 GLOFA CNET".

8.1.6 GLOFA GM Series (Ethernet UDP/IP)

Communication Setting

Editor

Make the following settings on the editor. For more information, see "1.3.2 Ethernet Communication".

- IP address for the V9 unit
 - When specified on the screen program:
[System Setting] → [Hardware Setting] → [Local Port IP Address]
 - When specified on the V9 unit:
Local mode → [LAN Setting]
- Port number for the V9 unit (for communication with PLC)
[System Setting] → [Hardware Setting] → [PLC Properties] → [Communication Setting]
- IP address and port number (No. 2005) of the PLC
Register on the [PLC Table] in [System Setting] → [Hardware Setting] → [PLC Properties] → [Target Settings].

PLC

Set the IP address using "Enet Editor".

The port number is fixed to "2005".

For more information, refer to the PLC manual issued by the manufacturer.

Calendar

This model is not equipped with the calendar function. Use the built-in clock of the V series.

Available Device Memory

The contents of "Available Device Memory" are the same as those described in "8.1.3 GLOFA CNET".

8.1.7 XGT/XGK Series CNET

Communication Setting

Editor

Communication setting

(Underlined setting: default)

Item	Setting	Remarks
Connection Mode	<u>1</u> : 1 / 1 : n / Multi-link2 / Multi-link2 (Ethernet) / 1 : n Multi-link2 (Ethernet)	
Signal Level	<u>RS-232C</u> / RS-422/485	
Baud Rate	4800 / <u>9600</u> / 19200 / 38400 /57600 / 115200 bps	
Data Length	7 / <u>8</u> bits	
Stop Bit	<u>1</u> / 2 bits	
Parity	<u>None</u> / Odd / Even	
Target Port No.	<u>0</u> to 31	

PLC

Set parameters using "XG_PD". For more information, refer to the PLC manual issued by the manufacturer.

Communication setting

(Underlined setting: default)

Item	Setting	Remarks
Type	<u>RS-232C</u> / RS-422	
Speed	4800 / <u>9600</u> / 19200 / 38400 /57600 / 115200 bps	
Data bit	7 / <u>8</u> bits	
Stop Bit	<u>1</u> / 2 bits	
Parity	<u>None</u> / Odd / Even	
Station	<u>0</u> to 31	

Calendar

This model is equipped with a calendar function; however, the calendar data cannot be written from the V series. Thus, time correction must be performed on the PLC side.

Available Device Memory

The available setting range of device memory varies depending on the PLC model. Be sure to set within the range available for the PLC to be used. Use [TYPE] when assigning indirect device memory for macro programs.

Device Memory	TYPE	Remarks
P (input/output relay)	00H	PW as word device, input relay: read only
M (auxiliary relay)	01H	MW as word device
L (link relay)	02H	LW as word device
K (keep relay)	03H	KW as word device
F (special relay)	04H	FW as word device; FW0 to FW1023: read only
T (timer/current value)	05H	
C (counter/current value)	06H	
D (data register)	07H	
TC (timer/contact)	09H	
CC (counter/contact)	0AH	
N (communication data register)	0BH	
R (file register)	0CH	RW as word device
ZR (file register)	0DH	
U (analog data register)	0EH	UW as word device *1

*1 The assigned device memory is expressed as shown on the right when editing the screen.

Example: U 3 1 . 31 . F

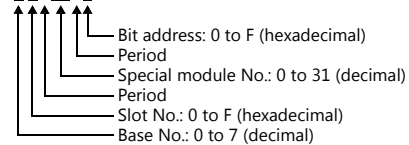

Indirect Device Memory Designation

	15	8	7	0
n+0	Model		Device type	
n+1	Address No.			
n+2	Expansion code		Bit designation	
n+3	00		Station number	

Example: Indirect device memory designation of "UW1F.31"

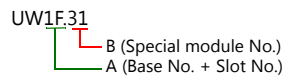

Address number = A converted to decimal \times 32 + B = 1F (HEX) \rightarrow 31 (DEC) \times 32 + 31 = 1023

Specify "1023" (DEC) for the address number.

8.1.8 XGT/XGK Series CPU

Communication Setting

Editor

Communication setting

(Underlined setting: default)

Item	Setting	Remarks
Connection Mode	<u>1</u> :1 / Multi-link2 / Multi-link2 (Ethernet)	
Signal Level	<u>RS-232C</u>	
Baud Rate	<u>115200</u> bps	
Data Length	<u>8</u> bits	
Stop Bit	<u>1</u> bit	
Parity	<u>None</u>	

PLC

No particular setting is necessary on the PLC.

The following settings are fixed; baud rate: 115200 bps, data length: 8 bits, without parity, and stop bit: 1 bit.

Available Device Memory

The contents of "Available Device Memory" are the same as those described in "8.1.7 XGT/XGK Series CNET".

8.1.9 XGT / XGK Series (Ethernet)

Communication Setting

Editor

Make the following settings on the editor. For more information, see "1.3.2 Ethernet Communication".

- IP address for the V9 unit
 - When specified on the screen program:
[System Setting] → [Hardware Setting] → [Local Port IP Address]
 - When specified on the V9 unit:
Local mode → [LAN Setting]
- Port number for the V9 unit (for communication with PLC)
[System Setting] → [Hardware Setting] → [PLC Properties] → [Communication Setting]
- IP address and port number (No. 2004 for TCP/IP or No. 2005 for UDP/IP) of the PLC
Register on the [PLC Table] in [System Setting] → [Hardware Setting] → [PLC Properties] → [Target Settings].

PLC

Go to [Standard Settings] in XG-PD and set the IP address.

The port numbers are 2004 for TCP/IP and 2005 for UDP/IP (both fixed).

For more information, refer to the PLC manual issued by the manufacturer.

Calendar

Although this model is equipped with the calendar function, the V series cannot read and write to the calendar. Use the built-in clock of the V series.

Available Device Memory

The contents of "Available Device Memory" are the same as those described in "8.1.7 XGT/XGK Series CNET".

8.1.10 XGT / XGI Series CNET

Communication Setting

Editor

Communication setting

(Underlined setting: default)

Item	Setting	Remarks
Connection Mode	<u>1:1</u> / 1 : n / Multi-link2 / Multi-link2 (Ethernet) / 1 : n Multi-link2 (Ethernet)	
Signal Level	<u>RS-232C</u> / RS-422/485	
Baud Rate	4800 / <u>9600</u> / 19200 / 38400 / 57600 / 115200 bps	
Data Length	7 / <u>8</u> bits	
Stop Bit	<u>1</u> / 2 bits	
Parity	<u>None</u> / Odd / Even	
Target Port No.	<u>0</u> to 31	

PLC

Set parameters in XG-PD. For more information, refer to the PLC manual issued by the manufacturer.

Communication settings

(Underlined setting: default)

Item	Setting	Remarks
Type	<u>RS-232C</u> / RS-422	
Speed	4800 / <u>9600</u> / 19200 / 38400 / 57600 / 115200 bps	
Data bit	7 / <u>8</u> bits	
Stop Bit	<u>1</u> / 2 bits	
Parity bit	<u>None</u> / Odd / Even	
Station Number	<u>0</u> to 31	

Calendar

This model is equipped with a calendar function; however, the calendar data cannot be written from the V series. Thus, time correction must be performed on the PLC side.

Available Device Memory

The available setting range of device memory varies depending on the PLC model. Be sure to set within the range available for the PLC to be used. Use [TYPE] when assigning indirect device memory for macro programs.

Device Memory	TYPE	Remarks
M (internal memory)	00H	MW as word device
Q (output)	01H	QW as word device *1
I (input)	02H	IW as word device *1
R (internal memory)	03H	RW as word device
W (internal memory)	04H	WW as word device
F (system flag)	05H	FW as word device; FW0 to FW1919: read only
K (PID flag)	06H	KW as word device
L (link flag)	07H	LW as word device
N (P2P flag)	08H	NW as word device
U (analog data register)	09H	UW as word device *1

*1 The assigned device memory is expressed as shown on the right when editing the screen.

Example: Q 0 . 0 . 0

Indirect Device Memory Designation

- For the address number of 0 to 65535:

	15	8 7	0
n+0	Model		Device type
n+1	Address No.		
n+2	Expansion code		Bit designation
n+3	00		Station number

- For the address number of 65536 or greater:

	15	8 7	0
n+0	Model		Device type
n+1	Lower address No.		
n+2	Higher address No.		
n+3	Expansion code		Bit designation
n+4	00		Station number

- Using Q or I device memory

- Word access

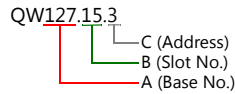

$$\text{Address number} = A \times 64 + B \times 4 + C = 127 \times 64 + 15 \times 4 + 3 = 8191$$

Specify "8191" (DEC) for the address number.

- Bit access

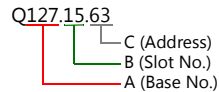

$$\begin{aligned} \text{Address number} &= A \times 64 + B \times 4 + (\text{quotient of } C \text{ divided by } 16) \\ &= 127 \times 64 + 15 \times 4 + (63 \div 16) = 8191 \end{aligned}$$

$$\text{Bit designation} = \text{remainder when } C \text{ is divided by } 16 = (63 \div 16) = 15$$

Specify "8191" (DEC) for the address number, and "15" (DEC) for the bit designation.

- Using U device memory

- Word access

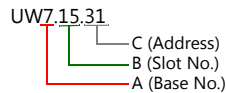

$$\text{Address number} = A \times 512 + B \times 32 + C = 7 \times 512 + 15 \times 32 + 31 = 4095$$

Specify "4095" (DEC) for the address number.

- Bit access

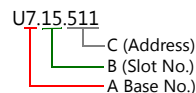

$$\begin{aligned} \text{Address number} &= A \times 512 + B \times 32 + (\text{quotient of } C \text{ divided by } 16) \\ &= 7 \times 512 + 15 \times 32 + (511 \div 16) = 4095 \end{aligned}$$

Specify "4095" (DEC) for the address number, and "15" (DEC) for the bit designation.

8.1.11 XGT / XGI Series CPU

Communication Setting

Editor

Communication setting

(Underlined setting: default)

Item	Setting	Remarks
Connection Mode	<u>1:1</u> / Multi-link2 / Multi-link2 (Ethernet)	
Signal Level	<u>RS-232C</u>	
Baud Rate	<u>115200</u> bps	
Data Length	<u>8</u> bits	
Stop Bit	<u>1</u> bit	
Parity	<u>None</u>	

PLC

No particular setting is necessary on the PLC.

Baud rate: 115200 bps, data length: 8 bits, without parity, stop bit: 1 bit (fixed)

Calendar

This model is equipped with a calendar function; however, the calendar data cannot be written from the V series. Thus, time correction must be performed on the PLC side.

Available Device Memory

The available setting range of device memory varies depending on the PLC model. Be sure to set within the range available for the PLC to be used. Use [TYPE] when assigning indirect device memory for macro programs.

Device Memory	TYPE	Remarks
M (internal memory)	00H	MW as word device; MW0 to MW65535 valid
Q (output)	01H	QW as word device *1
I (input)	02H	IW as word device *1
R (internal memory)	03H	RW as word device
W (internal memory)	04H	WW as word device
F (system flag)	05H	FW as word device; FW0 to FW1919: read only
K (PID flag)	06H	KW as word device
L (link flag)	07H	LW as word device
N (P2P flag)	08H	NW as word device
U (analog data register)	09H	UW as word device *1

*1 The assigned device memory is expressed as shown on the right when editing the screen.

Example: QW 0 . 0 . 0

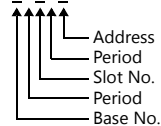

Indirect Device Memory Designation

	15	8 7	0
n+0	Model		Device type
n+1	Address No.		
n+2	Expansion code	Bit designation	
n+3	00	Station number	

- Using Q or I device memory

- Word access

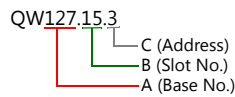

$$\text{Address number} = A \times 64 + B \times 4 + C = 127 \times 64 + 15 \times 4 + 3 = 8191$$

Specify "8191" (DEC) for the address number.

- Bit access

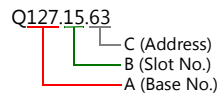

$$\begin{aligned} \text{Address number} &= A \times 64 + B \times 4 + (\text{quotient of } C \text{ divided by } 16) \\ &= 127 \times 64 + 15 \times 4 + (63 \div 16) = 8191 \end{aligned}$$

$$\text{Bit designation} = \text{remainder when } C \text{ is divided by } 16 = (63 \div 16) = 15$$

Specify "8191" (DEC) for the address number, and "15" (DEC) for the bit designation.

- Using U device memory

- Word access

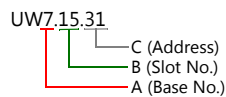

$$\text{Address number} = A \times 512 + B \times 32 + C = 7 \times 512 + 15 \times 32 + 31 = 4095$$

Specify "4095" (DEC) for the address number.

- Bit access

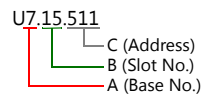

$$\begin{aligned} \text{Address number} &= A \times 512 + B \times 32 + (\text{quotient of } C \text{ divided by } 16) \\ &= 7 \times 512 + 15 \times 32 + (511 \div 16) = 4095 \end{aligned}$$

Specify "4095" (DEC) for the address number, and "15" (DEC) for the bit designation.

8.1.12 XGT / XGI Series (Ethernet)

Communication Setting

Editor

Make the following settings on the editor. For more information, see "1.3.2 Ethernet Communication".

- IP address for the V9 unit
 - When specified on the screen program:
[System Setting] → [Hardware Setting] → [Local Port IP Address]
 - When specified on the V9 unit:
Local mode → [LAN Setting]
- Port number for the V9 unit (for communication with PLC)
[System Setting] → [Hardware Setting] → [PLC Properties] → [Communication Setting]
- IP address and port number (No. 2004 for TCP/IP or No. 2005 for UDP/IP) of the PLC
Register on the [PLC Table] in [System Setting] → [Hardware Setting] → [PLC Properties] → [Target Settings].

PLC

Go to [Standard Settings] in XG-PD and set the IP address.
The port numbers are 2004 for TCP/IP and 2005 for UDP/IP (both fixed).
For more information, refer to the PLC manual issued by the manufacturer.

Calendar

This model is equipped with a calendar function; however, the calendar data cannot be written from the V series. Thus, time correction must be performed on the PLC side.

Available Device Memory

The contents of "Available Device Memory" are the same as those described in "8.1.10 XGT / XGI Series CNET".

8.1.13 Wiring Diagrams

When Connected at CN1:

RS-232C

Wiring diagram 1 - C2

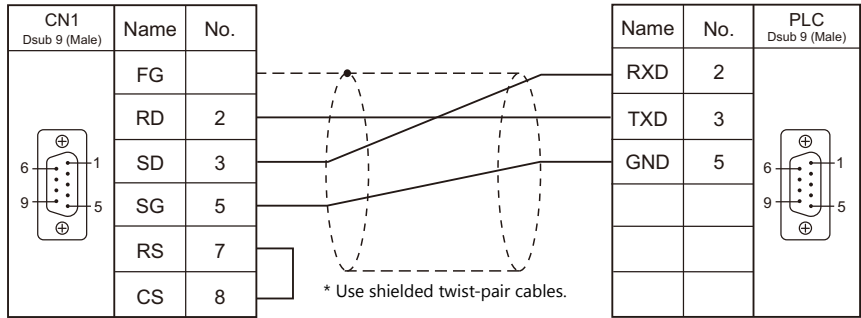

Wiring diagram 2 - C2

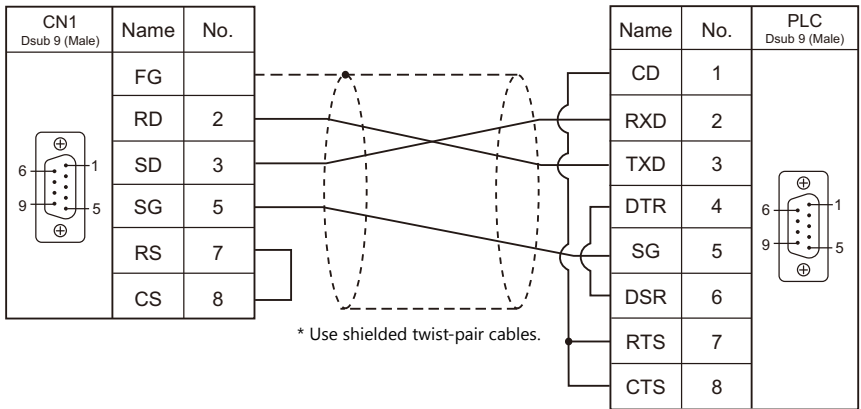

RS-422

Wiring diagram 1 - C4

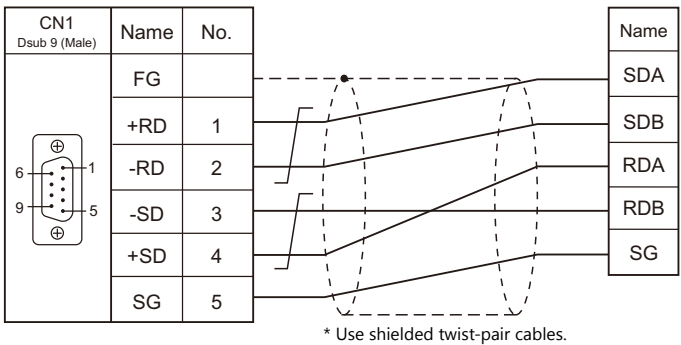

Wiring diagram 2 - C4

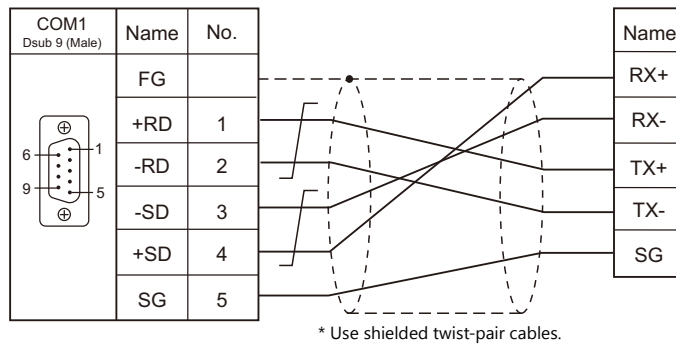

When Connected at MJ1/MJ2:

RS-232C

Wiring diagram 1 - M2

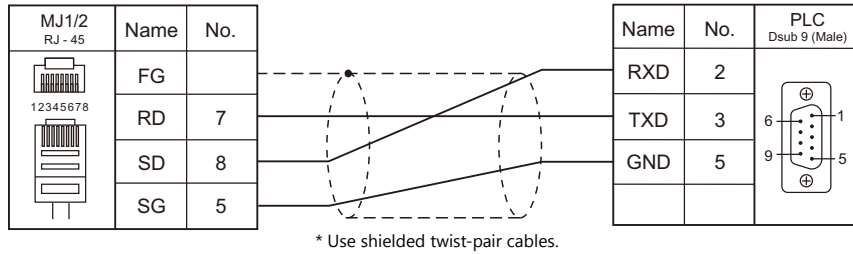

Wiring diagram 2 - M2

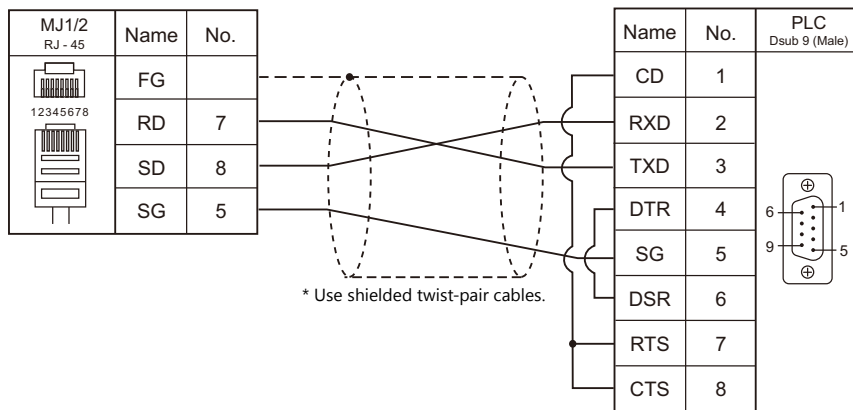

RS-422

Wiring diagram 1 - M4

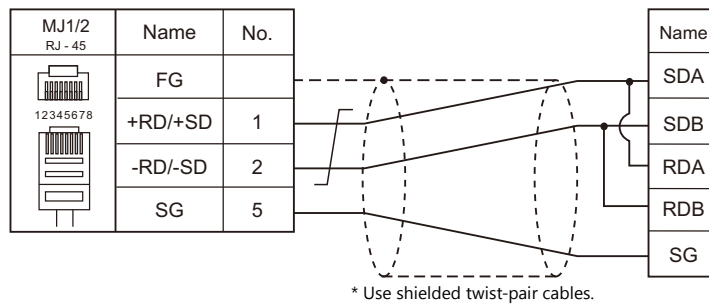

Wiring diagram 2 - M4

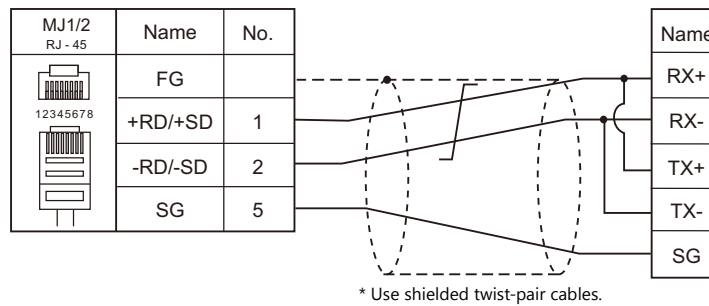

9. MITSUBISHI ELECTRIC

9.1 PLC Connection

9.2 Temperature Controller/Servo/Inverter Connection

9.1 PLC Connection

Serial Connection

A/QnA/QnH/L Series Standard Type Link Unit

PLC Selection on the Editor	CPU	Unit/Port	Signal Level	Connection		Ladder Transfer *1
				CN1	MJ1/MJ2	
A series link A-Link + Net10	A2A, A3A	AJ71C24-S6 AJ71C24-S8 AJ71UC24	RS-232C	Wiring diagram 2 - C2	Wiring diagram 2 - M2	×
	A2U, A3U, A4U	AJ71UC24				
	A1, A2, A3 A1N, A2N, A3N A3H, A3M, A73	AJ71C24 AJ71C24-S3 AJ71C24-S6 AJ71C24-S8 AJ71UC24	RS-422	Hakko Electronics' cable "D9-MI4-0T" or Wiring diagram 1 - C4	Wiring diagram 1 - M4	
	A0J2, A0J2H	A0J2C214-S1				
	A2US	A1SJ71UC24-R2	RS-232C	Hakko Electronics' cable "D9-MI2-09" or Wiring diagram 1 - C2	Wiring diagram 1 - M2	
		A1SJ71UC24-R4	RS-422	Hakko Electronics' cable "D9-MI4-0T" or Wiring diagram 1 - C4	Wiring diagram 1 - M4	
		A1SJ71UC24-PRF	RS-232C	Hakko Electronics' cable "D9-MI2-09" or Wiring diagram 1 - C2	Wiring diagram 1 - M2	
	A1S, A1SJ, A2S	A1SJ71C24-R2				
	A1S, A1SJ, A2S	A1SJ71C24-R4	RS-422	Hakko Electronics' cable "D9-MI4-0T" or Wiring diagram 1 - C4	Wiring diagram 1 - M4	
		A1SJ71C24-PRF	RS-232C	Hakko Electronics' cable "D9-MI2-09" or Wiring diagram 1 - C2	Wiring diagram 1 - M2	
		A2CCPUC24				
	QnH (A mode)	A1SJ71UC24-R2	RS-422	Hakko Electronics' cable "D9-MI4-0T" or Wiring diagram 1 - C4	Wiring diagram 1 - M4	
		A1SJ71UC24-R4				
	QnA series link	Q2A, Q3A, Q4A	AJ71QC24 AJ71QC24N	RS-232C	Wiring diagram 2 - C2	
AJ71QC24-R4 (CH1)			RS-422	Hakko Electronics' cable "D9-MI4-0T" or Wiring diagram 1 - C4	×	
AJ71QC24-R4 (CH2)			RS-422	Wiring diagram 2 - C4	×	
AJ71QC24-R4 (CH2)			RS-422	Hakko Electronics' cable "D9-MI4-0T" or Wiring diagram 1 - C4	×	
Q2ASx		A1SJ71QC24 A1SJ71QC24N A1SJ71QC24-R2	RS-232C	Hakko Electronics' cable "D9-MI2-09" or Wiring diagram 1 - C2	Wiring diagram 1 - M2	
			RS-422	Hakko Electronics' cable "D9-MI4-0T" or Wiring diagram 1 - C4	×	

PLC Selection on the Editor	CPU	Unit/Port	Signal Level	Connection		Ladder Transfer *1
				CN1	MJ1/MJ2	
QnH (Q) series link	Q02, Q02H Q06H Q12H Q25H	QJ71C24 QJ71C24N QJ71C24-R2 QJ71C24N-R2 QJ71C24N-R4	RS-232C	Hakko Electronics' cable "D9-MI2-09" or Wiring diagram 1 - C2	Wiring diagram 1 - M2	×
	Q00, Q01, Q00J					
QnH (Q) series link (multi CPU)	Q00UJ, Q00U Q01U, Q02U Q03UD(E) Q04UD(E)H Q06UD(E)H Q10UD(E)H Q13UD(E)H Q20UD(E)H Q26UD(E)H Q50UDEH Q100UDEH	QJ71C24N QJ71C24N-R2 QJ71C24N-R4	RS-422	Hakko Electronics' cable "D9-MI4-0T" or Wiring diagram 1 - C4	×	×
	Q02, Q02H Q06H Q12H Q25H	QJ71C24 QJ71C24N QJ71C24-R2 QJ71C24N-R2 QJ71C24N-R4	RS-232C	Hakko Electronics' cable "D9-MI2-09" or Wiring diagram 1 - C2	Wiring diagram 1 - M2	
L series link	L02CPU L26CPU-BT	LJ71C24 LJ71C24-R2	RS-232C	Hakko Electronics' cable "D9-MI2-09" or Wiring diagram 1 - C2	Wiring diagram 1 - M2	×
			RS-422	Hakko Electronics' cable "D9-MI4-0T" or Wiring diagram 1 - C4	×	

*1 For the ladder transfer function, see the V9 Series Reference Manual.

A/QnA/QnH/QnU Series/Q170M CPU

PLC Selection on the Editor	CPU	Port	Signal Level	Connection		Ladder Transfer *2
				CN1	MJ1/MJ2	
A series CPU	A2A, A3A A2U, A3U, A4U A2US (H) A1N, A2N, A3N A3V, A73 A3H, A3M A0J2H A1S (H), A1SJ (H) A2S (H) A2CCPUC24 A1FX	Tool port *1	RS-422	Hakko Electronics' cable "D9-MB-CPUQ" or Wiring diagram 3 - C4	×	○
QnA series CPU	Q2A, Q3A, Q4A Q2AS (H)					×
QnH (Q) series CPU	Q02, Q02H	Tool port	RS-232C	Hakko Electronics' cable "D9-QCPU2"	Hakko Electronics' cable "D9-QCPU2" + Wiring diagram 5 - M2 or MJ2-PLC+QCPU2	○
QnH (Q) series CPU (multi CPU)	Q06H Q12H Q25H	Tool port *3				
Q00J/00/01 CPU	Q00J, Q00, Q01	Tool port				
QnU series CPU	Q00UJ, Q00U Q01U, Q02U Q03UD, Q04UDH Q06UDH, Q10UDH Q13UDH, Q20UDH Q26UDH	Tool port				
Q170M CPU (multi CPU)	Q170M	Tool port				

*1 For more information of "V-MDD" (dual port interface), see page 9-57.

*2 For the ladder transfer function, see the V9 Series Reference Manual.

*3 Available for the CPU function version B or later.

FX Series

PLC Selection on the Editor	CPU	Port	Signal Level	Connection		Ladder Transfer *2
				CN1	MJ1/MJ2	
FX series CPU	FX1 FX2	Tool port *1	RS-422	Hakko Electronics' cable "D9-MB-CPUQ"	×	×
	FX0N	Tool port *1	RS-422	Hakko Electronics' cable "D9-MI4-FX" or Hakko Electronics' cable "D9-MB-CPUQ" + Mitsubishi's cable "FX-20P-CADP"	×	○
FX2N/1N series CPU	FX2N FX1N FX2NC FX1NC	Tool port *1	RS-422	Hakko Electronics' cable "D9-MI4-FX" or Hakko Electronics' cable "D9-MB-CPUQ" + Mitsubishi's cable "FX-20P-CADP"	×	○
FX1S series CPU	FX1S	Tool port *1	RS-422	Hakko Electronics' cable "D9-MI4-FX" or Hakko Electronics' cable "D9-MB-CPUQ" + Mitsubishi's cable "FX-20P-CADP"	×	○
FX series link (A protocol)	FX2N	FX2N-232-BD	RS-232C	Hakko Electronics' cable "D9-MI2-FX2N-2M" or Wiring diagram 3 - C2	Wiring diagram 3 - M2	×
		FX2N-485-BD	RS-485	Hakko Electronics' cable "D9-MI4-0T"*3 or Wiring diagram 1 - C4	Wiring diagram 1 - M4	
		FX2N-422-BD	RS-422	Hakko Electronics' cable "D9-MI4-FX"	×	
	FX1N FX1S	FX1N-232-BD	RS-232C	Hakko Electronics' cable "D9-MI2-FX2N-2M" or Wiring diagram 3 - C2	Wiring diagram 3 - M2	
		FX1N-485-BD	RS-485	Hakko Electronics' cable "D9-MI4-0T"*3 or Wiring diagram 1 - C4	Wiring diagram 1 - M4	
		FX1N-422-BD	RS-422	Hakko Electronics' cable "D9-MI4-FX"	×	
	FX0N FX1NC FX2NC	FX0N-232ADP	RS-232C	Wiring diagram 4 - C2	Wiring diagram 4 - M2	
		FX2NC-232ADP		Hakko Electronics' cable "D9-MI2-FX2N-2M" or Wiring diagram 3 - C2	Wiring diagram 3 - M2	
		FX0N-485ADP	RS-485	Hakko Electronics' cable "D9-MI4-0T"*3 or Wiring diagram 1 - C4	Wiring diagram 1 - M4	
		FX2NC-485ADP				
FX-3U/3UC/3G series CPU	FX-3U FX-3UC FX-3G	Tool port *1	RS-422	Hakko Electronics' cable "D9-MI4-FX" or Hakko Electronics' cable "D9-MB-CPUQ" + Mitsubishi's cable "FX-20P-CADP"	×	○

PLC Selection on the Editor	CPU	Port	Signal Level	Connection		Ladder Transfer *2
				CN1	MJ1/MJ2	
FX3U/3UC/3G series link (A protocol)	FX-3G	FX3G-232BD	RS-232C	Hakko Electronics' cable "D9-MI2-FX2N-2M" or Wiring diagram 3 - C2	Wiring diagram 3 - M2	×
		FX3G-485BD	RS-485	Hakko Electronics' cable "D9-MI4-0T"*3 or Wiring diagram 1 - C4	Wiring diagram 1 - M4	
	FX-3U	FX3U-232BD	RS-232C	Hakko Electronics' cable "D9-MI2-FX2N-2M" or Wiring diagram 3 - C2	Wiring diagram 3 - M2	
		FX3U-485BD	RS-485	Hakko Electronics' cable "D9-MI4-0T"*3 or Wiring diagram 1 - C4	Wiring diagram 1 - M4	
	FX-3UC	FX3U-232BD	RS-232C	Hakko Electronics' cable "D9-MI2-FX2N-2M" or Wiring diagram 3 - C2	Wiring diagram 3 - M2	
		FX3U-232ADP				
		FX3U-485BD	RS-485	Hakko Electronics' cable "D9-MI4-0T"*3 or Wiring diagram 1 - C4	Wiring diagram 1 - M4	
		FX3U-485ADP				

*1 For more information of "V-MDD" (dual port interface), see page 9-57.

*2 For the ladder transfer function, see the V9 Series Reference Manual.

*3 "D9-MI4-0T" is equipped with the Y-shaped terminal at the PLC side. Modification is necessary before use.

Ethernet Connection

QnA/QnH/Q170/L Series

PLC Selection on the Editor	CPU	Unit	TCP/IP	UDP/IP	Port No.	Keep Alive*1	Ladder Transfer *1
QnA series (Ethernet)	Q2A, Q3A, Q4A	AJ71QE71 AJ71QE71-B5	×	○	Auto-open: 5000		
	Q2ASx	A1S71QE71-B2 A1S71QE71-B5					
QnH (Q) series (Ethernet)	Q02, Q02H Q06H Q12H Q25H Q00J, Q00, Q01	QJ71E71 QJ71E71-B2 QJ71E71-100	×	○	Open setting: As desired (max. 16 units)		
	Q02U Q03UD Q04UDH, Q06UDH Q10UDH, Q13UDH Q20UDH, Q26UDH	QJ71E71-B2 QJ71E71-100	×	○			
	Q03UDE Q04UDEH, Q06UDEH Q10UDEH, Q13UDEH Q20UDEH, Q26UDEH Q50UDEH, Q100UDEH	CPU with built-in Ethernet	×	○	Open setting: As desired (max. 16 units)	○	×
QnH (Q) series (Ethernet ASCII)	Q02, Q02H Q06H Q12H Q25H Q00J, Q00, Q01	QJ71E71 QJ71E71-B2 QJ71E71-100	×	○	Open setting: As desired (max. 16 units)		
	Q02U Q03UD Q04UDH, Q06UDH Q10UDH, Q13UDH Q20UDH, Q26UDH	QJ71E71-B2 QJ71E71-100	×	○			
	Q03UDE Q04UDEH, Q06UDEH Q10UDEH, Q13UDEH Q20UDEH, Q26UDEH Q50UDEH, Q100UDEH	CPU with built-in Ethernet	×	○			

PLC Selection on the Editor	CPU	Unit	TCP/IP	UDP/IP	Port No.	Keep Alive ^{*1}	Ladder Transfer ^{*1}
QnH (Q) series (multi CPU) (Ethernet)	Q02, Q02H Q06H Q12H Q25H	QJ71E71 QJ71E71-B2 QJ71E71-100	×	○	Auto-open: 5000	○	×
	Q02U Q03UD Q04UDH, Q06UDH Q10UDH, Q13UDH Q20UDH, Q26UDH	QJ71E71-B2 QJ71E71-100	×	○	Open setting: As desired (max. 16 units)		
	Q03UDE Q04UDEH, Q06UDEH Q10UDEH, Q13UDEH Q20UDEH, Q26UDEH Q50UDEH, Q100UDEH		×	○	Open setting (max. 16 units)		
QnH (Q) series (multi CPU) (Ethernet)	Q02, Q02H Q06H Q12H Q25H	QJ71E71 QJ71E71-B2 QJ71E71-100	×	○	Open setting: As desired (max. 16 units)		
	Q02U Q03UD Q04UDH, Q06UDH Q10UDH, Q13UDH Q20UDH, Q26UDH	QJ71E71-B2 QJ71E71-100	×	○			
	Q03UDE Q04UDEH, Q06UDEH Q10UDEH, Q13UDEH Q20UDEH, Q26UDEH Q50UDEH, Q100UDEH		×	○			
QnU series (Built-in Ethernet)	Q03UDE Q04UDEH, Q06UDEH Q10UDEH, Q13UDEH Q20UDEH, Q26UDEH Q50UDEH, Q100UDEH	CPU with built-in Ethernet	○	○	Open setting: As desired (max. 16 units)		
Q170 series (multi CPU) (Ethernet)	Q170M Q172DCPU-S1 Q173DCPU-S1	CPU with built-in Ethernet	○	○	Open setting: As desired (max. 16 units)		
L series (Built-in Ethernet)	L02CPU L26CPU-BT	CPU with built-in Ethernet	○	○	Open setting: As desired (max. 16 units)		

*1 For KeepAlive functions, see "1.3.2 Ethernet Communication".

*2 For the ladder transfer function, see the V9 Series Reference Manual.

FX Series

PLC Selection on the Editor	CPU	Unit	TCP/IP	UDP/IP	Port No.	Keep Alive ^{*2}	Ladder Transfer ^{*3}
FX3U series (Ethernet)	FX3U (Version V2.21 or greater)	FX3U-ENET-L	×	○	Open setting: As desired (max. 2 units)	○	×
		FX3U-ENET			Open setting: As desired (max. 4 units)		
	FX3UC ^{*1} (Version V2.21 or greater)	FX3U-ENET-L	×	○	Open setting: As desired (max. 2 units)		

*1 FX2NC-CNV-IF or FX3UC-1PS-5V (Mitsubishi Electric) is required.

*2 For KeepAlive functions, see "1.3.2 Ethernet Communication".

*3 For the ladder transfer function, see the V9 Series Reference Manual.

9.1.1 A Series Link

Communication Setting

Editor

Communication setting

(Underlined setting: default)

Item	Setting	Remarks
Connection Mode	<u>1</u> : 1 / 1: n / Multi-link / Multi-link2 / Multi-link2 (Ethernet) / 1: n Multi-link2 (Ethernet)	
Signal Level	<u>RS-232C</u> / RS-422/485	
Baud Rate	4800 / 9600 / <u>19200</u> bps	
Transmission Mode	<u>Transmission Mode 1</u> / Transmission Mode 4	Transmission Mode 1: Without CR/LF Transmission Mode 4: With CR/LF
Data Length	<u>7</u> / 8 bits	
Stop Bit	<u>1</u> / 2 bits	
Parity	None / Odd / <u>Even</u>	
Target Port No.	<u>0</u> to 31	

PLC

Be sure to match the settings to those made under [Communication Setting] of the editor.

Mode setting

Mode	Setting	Contents	
	1	RS-232C	Dedicated protocol MODE 1
	4		Dedicated protocol MODE 4
	5	RS-422	Dedicated protocol MODE 1
	8		Dedicated protocol MODE 4

Station number setting

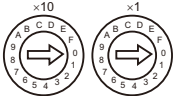
Station No.	Setting	Contents
	0 to 31	Station number x10: the tens place x1: the ones place

Transmission setting

AJ71UC24

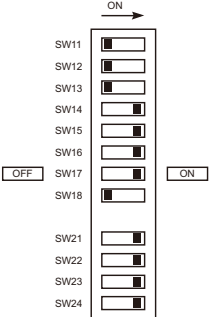
Switch	Contents	OFF	ON	Example: RS-232C, 19200 bps 
SW11	Main channel	RS-232C	RS-422	
SW12	Data bit	7	8	
SW13	Baud rate	9600	19200	
SW14		ON	OFF	
SW15		OFF	ON	
SW16	Parity bit	Not provided	Provided	
SW17	Parity	Odd	Even	
SW18	Stop bit	1	2	
SW21	Sum check	Not provided	Provided	
SW22	Write while running	Disabled	Enabled	
SW23	Standard type link unit / multi-drop link unit	Multi	Standard	
SW24	Master station / local station	-	-	

A1SJ71C24-R2, A1SJ71UC24-R2

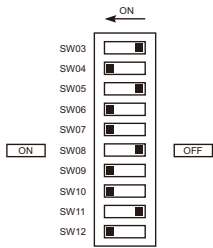
Switch	Contents	ON	OFF	Example: RS-232C, 19200 bps 
SW03	Not used	-	-	
SW04	Write while running	Enabled	Disabled	
		9600	19200	
SW05	Baud rate	ON	OFF	
SW06		OFF	ON	
SW07		ON	ON	
SW08	Data bit	8	7	
SW09	Parity bit	Provided	Not provided	
SW10	Parity	Even	Odd	
SW11	Stop bit	2	1	
SW12	Sum check	Provided	Not provided	

A1SJ71UC24-R4, A1SJ71C24-R4

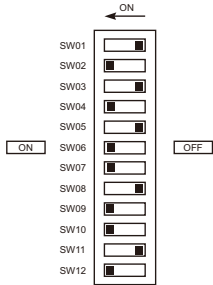
Switch	Contents	ON	OFF	Example: RS-422, 19200 bps 
SW01	Master station / local station	-	-	
SW02	Standard type link unit / multi-drop link unit	Standard	Multi	
SW03	Not used	-	-	
SW04	Write while running	Enabled	Disabled	
		9600	19200	
SW05	Baud rate	ON	OFF	
SW06		OFF	ON	
SW07		ON	ON	
SW08	Data bit	8	7	
SW09	Parity bit	Provided	Not provided	
SW10	Parity	Even	Odd	
SW11	Stop bit	2	1	
SW12	Sum check	Provided	Not provided	

Available Device Memory

The available setting range of device memory varies depending on the PLC model. Be sure to set within the range available for the PLC to be used. Use [TYPE] when assigning indirect device memory for macro programs.

Device Memory	TYPE	Remarks
D (data register)	00H	
W (link register)	01H	
R (file register)	02H	Cannot be set when the CPU is operated by ROM.
TN (timer/current value)	03H	
CN (counter/current value)	04H	
SPU (special unit buffer memory)	05H	*1
M (internal relay)	06H	
L (latch relay)	07H	
B (link relay)	08H	
X (input)	09H	
Y (output)	0AH	
TS (timer/contact)	0BH	
TC (timer/coil)	0CH	
CS (counter/contact)	0DH	
CC (counter/coil)	0EH	
H (link unit buffer memory)	0FH	

*1 The unit number is required in addition to the device type and address. Convert byte address into word address when entering the data on the editor if the memory device of the link unit is byte address.
For the unit number, set the decimal number of "XXX" included in the station I/O number "xxx0 H" of the link unit. For more information, see page 9-16.

9.1.2 A Series CPU

Communication Setting

Editor

Communication setting

Item	Setting	Remarks
Connection Mode	1 : 1 / Multi-link2 / Multi-link2 (Ethernet)	
Signal Level	RS-422/485	
Baud Rate	9600 bps	
Data Length	8 bits	
Stop Bit	1 bit	
Parity	Odd	

PLC

No particular setting is necessary on the PLC.

Available Device Memory

The available setting range of device memory varies depending on the PLC model. Be sure to set within the range available for the PLC to be used. Use [TYPE] when assigning indirect device memory for macro programs.

Device Memory	TYPE	Remarks
D (data register)	00H	
W (link register)	01H	
R (file register)	02H	Cannot be set when the CPU is operated by ROM.
TN (timer/current value)	03H	
CN (counter/current value)	04H	
SPU (special unit buffer memory)	05H	*1
M (internal relay)	06H	
L (latch relay)	07H	
B (link relay)	08H	
X (input)	09H	
Y (output)	0AH	
TS (timer/contact)	0BH	
TC (timer/coil)	0CH	
CS (counter/contact)	0DH	
CC (counter/coil)	0EH	

*1 The unit number is required in addition to the device type and address. Convert byte address into word address when entering the data on the editor if the memory device of the link unit is byte address.
For the unit number, set the decimal number of "XXX" included in the station I/O number "xxx0 H" of the link unit. For more information, see page 9-16.

9.1.3 QnA Series Link

Communication Setting

Editor

Communication setting

(Underlined setting: default)

Item	Setting	Remarks
Connection Mode	<u>1:1</u> / 1:n / Multi-link2 / Multi-link2 (Ethernet) / 1:n Multi-link2 (Ethernet)	
Signal Level	<u>RS-232C</u> / RS-422/485	
Baud Rate	4800 / 9600 / 19200 / 38400 / 57600 / <u>115K</u> bps	
Data Length	8 bits	
Stop Bit	<u>1</u> / 2 bits	
Parity	None / Odd / <u>Even</u>	
Target Port No.	<u>0</u> to 31	

PLC

Be sure to match the settings to those made under [Communication Setting] of the editor.

Mode setting

Mode	Setting	Contents
	5	Dedicated protocol binary mode Mode 5

Station number setting

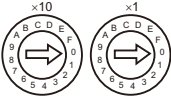
Station No.	Setting	Contents
	0 to 31	Station number x10: the tens place x1: the ones place

Transmission setting

AJ71QC24, AJ71QC24N, A1SJ71QC24

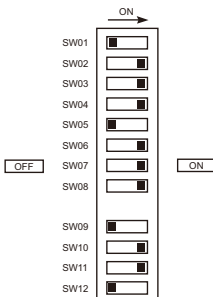
Switch	Contents	OFF	ON	Example: 19200 bps 				
SW01	Operation	Independent	Link					
SW02	Data bit	7	8					
SW03	Parity bit	Not provided	Provided					
SW04	Parity	Odd	Even					
SW05	Stop bit	1	2					
SW06	Sum check	Not provided	Provided					
SW07	Write while running	Disabled	Enabled					
SW08	Setting change	Disabled	Enabled					
SW09	Baud rate *1	9600	19200					
SW10		38400	57600					
SW11		115200						
SW12								
		ON	OFF	ON	OFF	ON	OFF	ON
		OFF	ON	ON	ON	ON	ON	ON
		ON	ON	ON	OFF	OFF	OFF	OFF
		OFF	OFF	OFF	ON	ON	ON	ON

*1 AJ71C24 (-R2/-R4): Max. 19200 bps
AJ71C24N (-R2/-R4): Max. 115200 bps (When CH1 and CH2 are used at the same time, a maximum of 115200 bps can be set in total.)

Available Device Memory

The available setting range of device memory varies depending on the PLC model. Be sure to set within the range available for the PLC to be used. Use [TYPE] when assigning indirect device memory for macro programs.

Device Memory	TYPE	Remarks
D (data register)	00H	
W (link register)	01H	
R (file register)	02H	
TN (timer/current value)	03H	
CN (counter/current value)	04H	
SPU (special unit buffer memory)	05H	*1
M (internal relay)	06H	
L (latch relay)	07H	
B (link relay)	08H	
X (input)	09H	
Y (output)	0AH	
TS (timer/contact)	0BH	
TC (timer/coil)	0CH	
CS (counter/contact)	0DH	
CC (counter/coil)	0EH	
H (link unit buffer memory)	0FH	
SD (special register)	10H	
SM (special relay)	11H	
SB (special link relay)	12H	
SW (special link register)	13H	
ZR (file register (for continuous access))	14H	
F (annunciator)	15H	

*1 The unit number is required in addition to the device type and address. Convert byte address into word address when entering the data on the editor if the memory device of the link unit is byte address.
For the unit number, set the decimal number of "XXX" included in the station I/O number "xxx0 H" of the link unit. For more information, see page 9-16.

9.1.4 QnA Series CPU

Communication Setting

Editor

Communication setting

Item	Setting	Remarks
Connection Mode	1-1 / Multi-link / Multi-link2 / Multi-link2 (Ethernet)	"V-MDD" is necessary for multi-link.
Signal Level	RS-422/485	
Baud Rate	19200 bps	
Data Length	8 bits	
Stop Bit	1 bit	
Parity	Odd	

PLC

No particular setting is necessary on the PLC.

Available Device Memory

The available setting range of device memory varies depending on the PLC model. Be sure to set within the range available for the PLC to be used. Use [TYPE] when assigning indirect device memory for macro programs.

Device Memory	TYPE	Remarks
D (data register)	00H	
W (link register)	01H	
R (file register)	02H	
TN (timer/current value)	03H	
CN (counter/current value)	04H	
SPU (special unit buffer memory)	05H	*1
M (internal relay)	06H	
L (latch relay)	07H	
B (link relay)	08H	
X (input)	09H	
Y (output)	0AH	
TS (timer/contact)	0BH	
TC (timer/coil)	0CH	
CS (counter/contact)	0DH	
CC (counter/coil)	0EH	
SD (special register)	10H	
SM (special relay)	11H	
SB (special link relay)	12H	
SW (special link register)	13H	
ZR (file register (for continuous access))	14H	
F (annunciator)	15H	

*1 The unit number is required in addition to the device type and address. Convert byte address into word address when entering the data on the editor if the memory device of the link unit is byte address.
For the unit number, set the decimal number of "XXX" included in the station I/O number "xxx0 H" of the link unit. For more information, see page 9-16.

9.1.5 QnA Series (Ethernet)

Communication Setting

Editor

Make the following settings on the editor. For more information, see "1.3.2 Ethernet Communication".

- IP address for the V9 unit
 - When specified on the screen program:
[System Setting] → [Hardware Setting] → [Local Port IP Address]
 - When specified on the V9 unit:
Local mode → [LAN Setting]
- Port number for the V9 unit (for communication with PLC)
[System Setting] → [Hardware Setting] → [PLC Properties] → [Communication Setting]

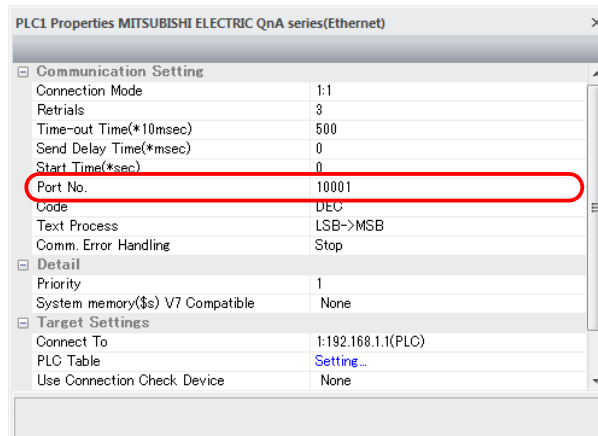

- IP address and port number of the PLC
[System Setting] → [Hardware Setting] → [PLC Properties] → [Target Settings]

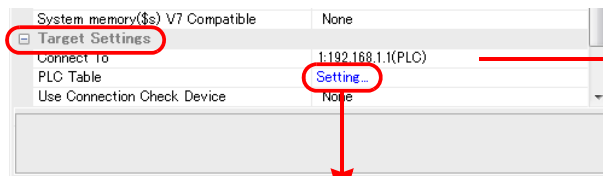

Valid only for 1 : 1 connection
Select the PLC for connection from those registered on the PLC table.

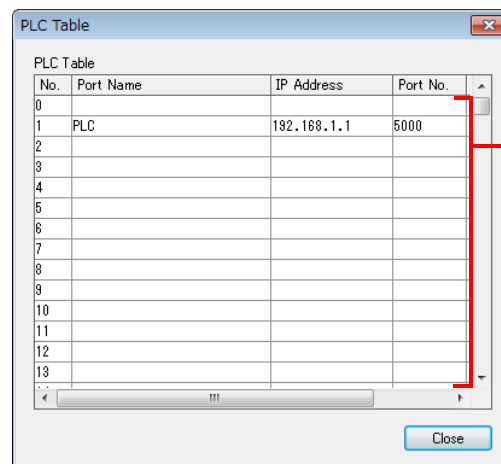

Set the IP address, port number and whether or not to use the KeepAlive function of the PLC.

PLC

PC parameter

Make the I/O assignment setting for the Ethernet unit.

Network parameter (Ethernet)

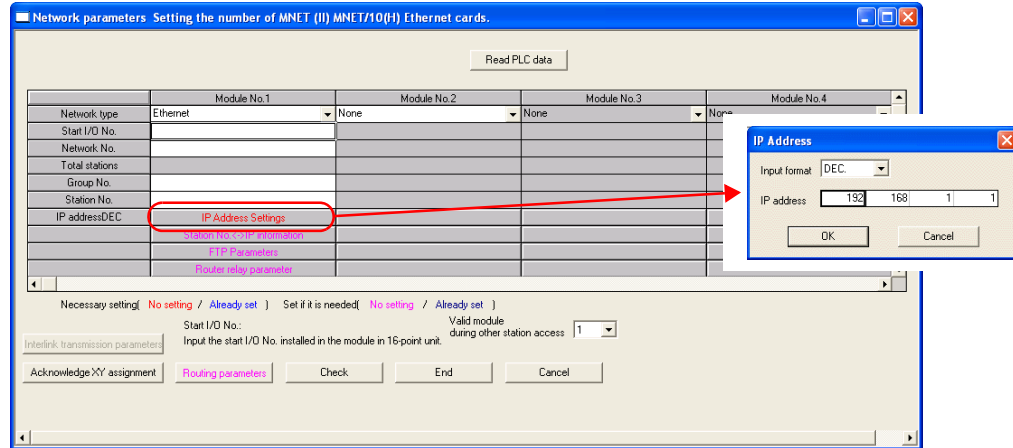

Item	Setting	Remarks
Network type	Ethernet	For more information, refer to the manual of the PLC.
Station I/O No.	Make settings in accordance with the network environment.	
Network No.		
Group No.		
Station No.		
IP address (DEC)		

Port No.

There are two types of ports: one is opened automatically by "auto-open UDP port" (default: 5000 DEC), and the other is opened by open processing.

For more information, refer to the corresponding PLC manual.

Available Device Memory

The available setting range of device memory varies depending on the PLC model. Be sure to set within the range available for the PLC to be used. Use [TYPE] when assigning indirect device memory for macro programs.

Device Memory	TYPE	Remarks
D (data register)	00H	
W (link register)	01H	
R (file register)	02H	
TN (timer/current value)	03H	
CN (counter/current value)	04H	
SPU (special unit buffer memory)	05H	*1
M (internal relay)	06H	
L (latch relay)	07H	
B (link relay)	08H	
X (input)	09H	
Y (output)	0AH	
TS (timer/contact)	0BH	
TC (timer/coil)	0CH	
CS (counter/contact)	0DH	
CC (counter/coil)	0EH	
H (link unit buffer memory)	0FH	
SD (special register)	10H	
SM (special relay)	11H	
SB (special link relay)	12H	
SW (special link register)	13H	
ZR (file register (for continuous access))	14H	
F (annunciator)	15H	

*1 The unit number is required in addition to the device type and address. Convert byte address into word address when entering the data on the editor if the memory device of the link unit is byte address.
For the unit number, set the decimal number of "XXX" included in the station I/O number "xxx0 H" of the link unit. For more information, see page 9-16.

9.1.6 QnH (Q) Series Link

Communication Setting

Editor

Communication setting

(Underlined setting: default)

Item	Setting	Remarks
Connection Mode	<u>1</u> : <u>1</u> / 1 : n / Multi-link2 / Multi-link2 (Ethernet) / 1 : n Multi-link2 (Ethernet)	
Signal Level	<u>RS-232C</u> / RS-422/485	
Baud Rate	4800 / 9600 / 19200 / 38400 / 57600 / <u>115K</u> bps	
Data Length	8 bits	
Stop Bit	<u>1</u> / 2 bits	
Parity	None / Odd / <u>Even</u>	
Target Port No.	<u>0</u> to 31	

PLC (PC Parameter)

Switch setting for I/O and intelligent function module

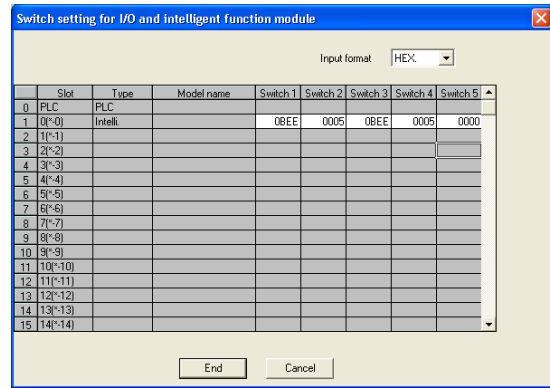
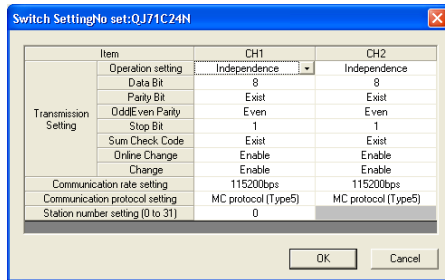

Switch	Contents	Example																																																		
Switch 1	<p>CH1: baud rate, transmission setting</p> <p>Bit 15 - 8 7 - 0</p> <p style="text-align: center;">Baud rate Transmission setting</p> <table border="1" style="display: inline-table; margin-right: 20px;"> <thead> <tr> <th>bps</th> <th>Setting</th> </tr> </thead> <tbody> <tr><td>4800</td><td>04H</td></tr> <tr><td>9600</td><td>05H</td></tr> <tr><td>19200</td><td>07H</td></tr> <tr><td>38400</td><td>09H</td></tr> <tr><td>57600</td><td>0AH</td></tr> <tr><td>115200</td><td>0BH</td></tr> </tbody> </table> <table border="1" style="display: inline-table;"> <thead> <tr> <th>Bit</th> <th>Contents</th> <th>OFF</th> <th>ON</th> </tr> </thead> <tbody> <tr><td>0</td><td>Operation</td><td>Independent</td><td>Link</td></tr> <tr><td>1</td><td>Data bit</td><td>7</td><td>8</td></tr> <tr><td>2</td><td>Parity bit</td><td>Not provided</td><td>Provided</td></tr> <tr><td>3</td><td>Parity</td><td>Odd</td><td>Even</td></tr> <tr><td>4</td><td>Stop bit</td><td>1</td><td>2</td></tr> <tr><td>5</td><td>Sum check</td><td>Not provided</td><td>Provided</td></tr> <tr><td>6</td><td>Write while running</td><td>Prohibited</td><td>Allowed</td></tr> <tr><td>7</td><td>Setting change</td><td>Prohibited</td><td>Allowed</td></tr> </tbody> </table>	bps	Setting	4800	04H	9600	05H	19200	07H	38400	09H	57600	0AH	115200	0BH	Bit	Contents	OFF	ON	0	Operation	Independent	Link	1	Data bit	7	8	2	Parity bit	Not provided	Provided	3	Parity	Odd	Even	4	Stop bit	1	2	5	Sum check	Not provided	Provided	6	Write while running	Prohibited	Allowed	7	Setting change	Prohibited	Allowed	<p>0BEEH</p> <p>115 kbps 8 bits 1 bit Even</p>
bps	Setting																																																			
4800	04H																																																			
9600	05H																																																			
19200	07H																																																			
38400	09H																																																			
57600	0AH																																																			
115200	0BH																																																			
Bit	Contents	OFF	ON																																																	
0	Operation	Independent	Link																																																	
1	Data bit	7	8																																																	
2	Parity bit	Not provided	Provided																																																	
3	Parity	Odd	Even																																																	
4	Stop bit	1	2																																																	
5	Sum check	Not provided	Provided																																																	
6	Write while running	Prohibited	Allowed																																																	
7	Setting change	Prohibited	Allowed																																																	
Switch 2	CH1: communication protocol	MC protocol mode 5 binary code	0005H																																																	
Switch 3	CH2: baud rate, transmission setting (the same as those for switch 1)		0BEEH																																																	
Switch 4	CH2: communication protocol	MC protocol mode 5 binary code	0005H																																																	
Switch 5	Station number setting	0 to 31	0000H																																																	

Available Device Memory

The available setting range of device memory varies depending on the PLC model. Be sure to set within the range available for the PLC to be used. Use [TYPE] when assigning indirect device memory for macro programs.

Device Memory	TYPE	Remarks
D (data register)	00H	
W (link register)	01H	
R (file register)	02H	
TN (timer/current value)	03H	
CN (counter/current value)	04H	
SPU (special unit buffer memory)	05H	*1
M (internal relay)	06H	
L (latch relay)	07H	
B (link relay)	08H	
X (input)	09H	
Y (output)	0AH	
TS (timer/contact)	0BH	
TC (timer/coil)	0CH	
CS (counter/contact)	0DH	
CC (counter/coil)	0EH	
H (link unit buffer memory)	0FH	
SD (special register)	10H	
SM (special relay)	11H	
SB (special link relay)	12H	
SW (special link register)	13H	
ZR (file register (for continuous access))	14H	
F (annunciator)	15H	
SS (totalizing timer/contact)	16H	
SC (totalizing timer/coil)	17H	
SN (totalizing timer/current value)	18H	
Z (index register)	19H	

*1 The unit number is required in addition to the device type and address. Convert byte address into word address when entering the data on the editor if the memory device of the link unit is byte address. For the unit number, set the decimal number of "XXX" included in the station I/O number "xxx0 H" of the link unit.

Example:

When the following settings are made for "Q02HCPU" and connection is established:

The screenshot shows the 'Q parameter setting' window with the following I/O Assignment table:

Slot	Type	Model name	Points	Start/XY
0	PLC	PLC		
1	0[*-0]	Intelli	32points	0080
2	1[*-1]	Input	16points	00A0
3	2[*-2]	Output	16points	00B0
4	3[*-3]			
5	4[*-4]			
6	5[*-5]			
7	6[*-6]			

The 'Acknowledge XY Assignment' window shows the following XY No. list:

XY No.	Type	Slot	Module type	Points	Model name	Duplication
0000	Network					
0070						
0080	I/O assignment	0[*-0]	Intelli	32	QJ71C24N	
0090	I/O assignment	0[*-0]	Intelli	32	QJ71C24N	
00A0	I/O assignment	1[*-1]	Input	16	G64AD	
00B0	I/O assignment	2[*-2]	Output	16	G64DAN	
00C0						
00D0						
00E0						
00F0						
0100						
0110						
0120						
0130						

- With the use of buffer memory of the serial communication unit: Unit No. = "8" (DEC)
- With the use of buffer memory of the input unit: Unit No. = "10" (DEC)
- With the use of buffer memory of the output unit: Unit No. = "11" (DEC)

9.1.7 QnH (Q) Series CPU

Communication Setting

Editor

Communication setting

(Underlined setting: default)

Item	Setting	Remarks
Connection mode	<u>1:1</u> / Multi-link2 / Multi-link2 (Ethernet)	
Signal level	RS-232C	
Baud rate	9600 / 19200 / 38400 / 57600 / <u>115K</u> bps	
Data length	8 bits	
Stop bit	1 bit	
Parity	Odd	

PLC

No particular setting is necessary on the PLC.

Available Device Memory

The available setting range of device memory varies depending on the PLC model. Be sure to set within the range available for the PLC to be used. Use [TYPE] when assigning indirect device memory for macro programs.

Device Memory	TYPE	Remarks
D (data register)	00H	
W (link register)	01H	
R (file register)	02H	
TN (timer/current value)	03H	
CN (counter/current value)	04H	
SPU (special unit buffer memory)	05H	*1
M (internal relay)	06H	
L (latch relay)	07H	
B (link relay)	08H	
X (input)	09H	
Y (output)	0AH	
TS (timer/contact)	0BH	
TC (timer/coil)	0CH	
CS (counter/contact)	0DH	
CC (counter/coil)	0EH	
SD (special register)	10H	
SM (special relay)	11H	
SB (special link relay)	12H	
SW (special link register)	13H	
ZR (file register (for continuous access))	14H	
F (annunciator)	15H	
SS (totalizing timer/contact)	16H	
SC (totalizing timer/coil)	17H	
SN (totalizing timer/current value)	18H	
Z (index register)	19H	

*1 The unit number is required in addition to the device type and address. Convert byte address into word address when entering the data on the editor if the memory device of the link unit is byte address.
For the unit number, set the decimal number of "XXX" included in the station I/O number "xxx0 H" of the link unit. For more information, see page 9-16.

9.1.8 QnH (Q) Series (Ethernet)

Communication Setting

Editor

Make the following settings on the editor. For more information, see “1.3.2 Ethernet Communication”.

- IP address for the V9 unit
 - When specified on the screen program:
[System Setting] → [Hardware Setting] → [Local Port IP Address]
 - When specified on the V9 unit:
Local mode → [LAN Setting]
- Port number for the V9 unit (for communication with PLC)
[System Setting] → [Hardware Setting] → [PLC Properties] → [Communication Setting]
- Others
[System Setting] → [Hardware Setting] → [PLC Properties] → [Communication Setting]
 - When connecting to the Ethernet unit, select [Yes] for the [Batch Readout of Multiple Blocks] setting.
 - When connecting to the built-in Ethernet port on the QnU series, select [Yes] for the [Random Readout] setting.

When connecting to the Ethernet unit

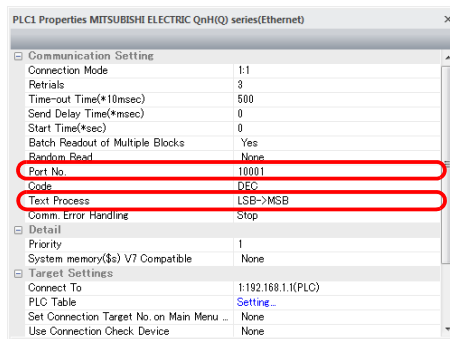

When connecting to the built-in Ethernet port on the QnU series

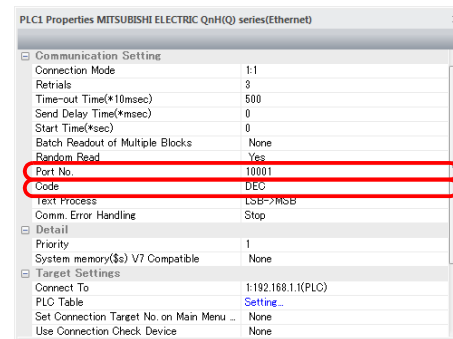

- IP address and port number of the PLC
Register on the PLC table in [System Setting] → [Hardware Setting] → [PLC Properties] → [Target Settings].

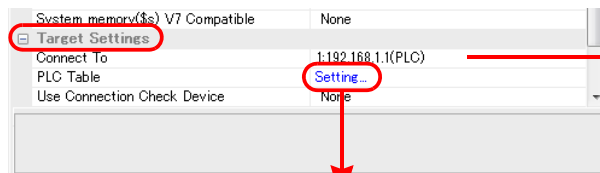

Valid only for 1 : 1 connection
Select the PLC for connection from those registered on the PLC table.

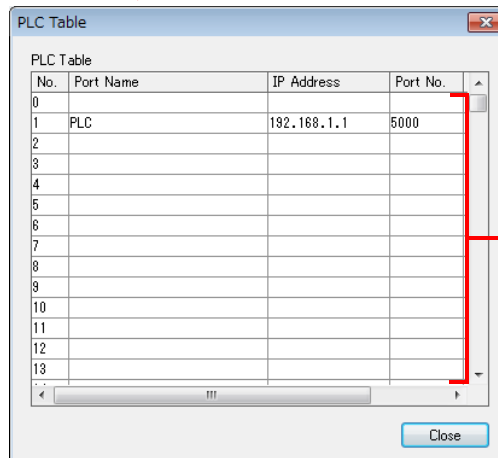

Set the IP address, port number and whether or not to use the KeepAlive function of the PLC.

PLC

Make the PLC setting using the programming tool "GX-Developer". For more information, refer to the PLC manual issued by the manufacturer.

Ethernet unit

PC parameter

Make the I/O assignment setting for the Ethernet unit.

Network parameter (Ethernet)

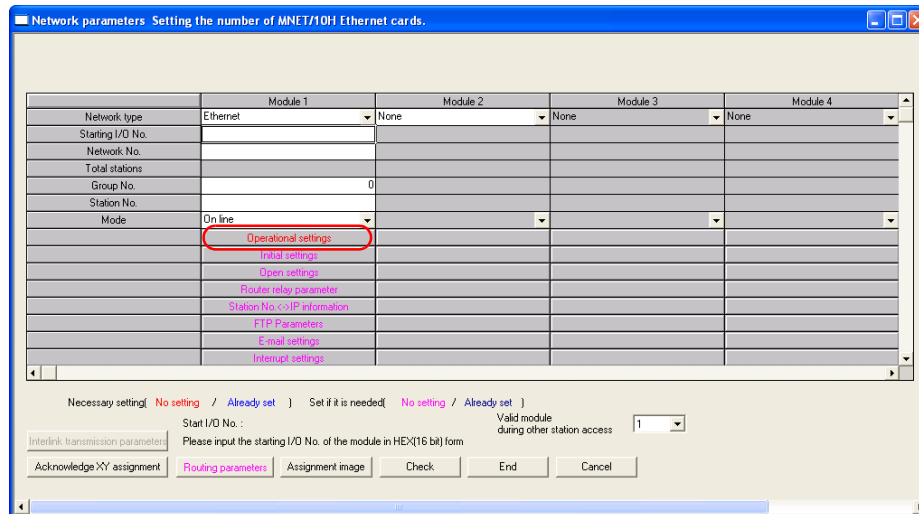

Item	Setting	Remarks
Network type	Ethernet	For more information, refer to the manual of the PLC.
Station I/O No.		
Network No.	Make settings in accordance with the network environment.	
Group No.		
Station No.		

Ethernet operations

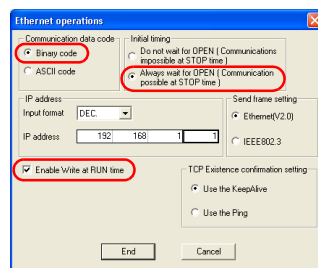

Item	Setting	Remarks
Communication data code	Binary code	
Initial timing	Always wait for OPEN (Communication possible at STOP time)	
IP address (DEC)	Make settings in accordance with the network environment.	
Enable Write at RUN time	Checked	It is not possible to write value from V9 to PLC when unchecked. If so, "error code received 7167" occurs.

Port No.

There are two types of ports: one is opened automatically by "auto-open UDP port" (default: 5000 DEC), and the other is opened by open processing. When using the open processing, make settings for [Open settings] on the [Network parameters] dialog. For more information, refer to the corresponding PLC manual.

Built-in Ethernet port

PC parameter

Make the settings for the IP address and the open settings in the [Built-in Ethernet port] tab window.

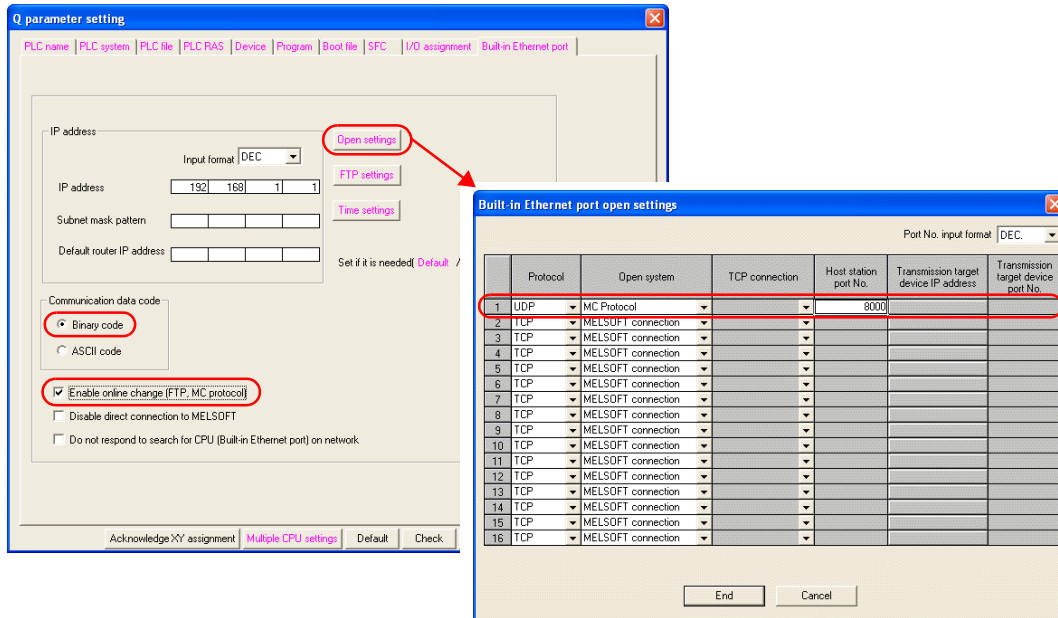

Item	Setting	Remarks
IP address (DEC)	Make settings in accordance with the network environment.	For more information, refer to the manual of the PLC.
Communication data code	Binary code	
Enable online change (FTP, MC protocol)	Checked	It is not possible to write value from V9 to PLC when unchecked. If so, "error code received 7167" occurs.
Protocol	UDP	
Open system	MC Protocol	
Host station port No. (DEC)	Make settings in accordance with the network environment.	It is not possible to set it from No. 5000 to 5009.

Available Device Memory

The available setting range of device memory varies depending on the PLC model. Be sure to set within the range available for the PLC to be used. Use [TYPE] when assigning indirect device memory for macro programs.

Device Memory	TYPE	Remarks
D (data register)	00H	
W (link register)	01H	
R (file register)	02H	
TN (timer/current value)	03H	
CN (counter/current value)	04H	
SPU (special unit buffer memory)	05H	Invalid on QnU series Built-in port ^{*1}
M (internal relay)	06H	
L (latch relay)	07H	
B (link relay)	08H	
X (input)	09H	
Y (output)	0AH	
TS (timer/contact)	0BH	Invalid on QnU series Built-in port
TC (timer/coil)	0CH	Invalid on QnU series Built-in port
CS (counter/contact)	0DH	Invalid on QnU series Built-in port
CC (counter/coil)	0EH	Invalid on QnU series Built-in port
H (link unit buffer memory)	0FH	Invalid on QnU series Built-in port
SD (special register)	10H	
SM (special relay)	11H	
SB (special link relay)	12H	
SW (special link register)	13H	
ZR (file register (for continuous access))	14H	
F (annunciator)	15H	
SS (totalizing timer/contact)	16H	
SC (totalizing timer/coil)	17H	
SN (totalizing timer/current value)	18H	
Z (index register)	19H	

*1 The unit number is required in addition to the device type and address. Convert byte address into word address when entering the data on the editor if the memory device of the link unit is byte address.
For the unit number, set the decimal number of "XXX" included in the station I/O number "xxx0 H" of the link unit. For more information, see page 9-16.

9.1.9 QnU Series CPU

The communication setting and available device memory are the same as those described in "9.1.7 QnH (Q) Series CPU".

9.1.10 Q00J/00/01 CPU

The communication setting and available device memory are the same as those described in "9.1.7 QnH (Q) Series CPU".

9.1.11 QnH (Q) Series Link (Multi CPU)

The communication setting and available device memory are the same as those described in "9.1.6 QnH (Q) Series Link".

9.1.12 QnH (Q) Series (Multi CPU) (Ethernet)

The communication setting and available device memory are the same as those described in "9.1.8 QnH (Q) Series (Ethernet)".

9.1.13 QnH (Q) Series CPU (Multi CPU)

The communication setting and available device memory are the same as those described in "9.1.7 QnH (Q) Series CPU".

9.1.14 QnH (Q) Series (Ethernet ASCII)

Communication Setting

Editor

Make the following settings on the editor. For more information, see “1.3.2 Ethernet Communication”.

- IP address for the V9 unit
 - When specified on the screen program:
[System Setting] → [Hardware Setting] → [Local Port IP Address]
 - When specified on the V9 unit:
Local mode → [LAN Setting]
- Port number for the V9 unit (for communication with PLC)
[System Setting] → [Hardware Setting] → [PLC Properties] → [Communication Setting]
- Others
[System Setting] → [Hardware Setting] → [PLC Properties] → [Communication Setting]
 - When connecting to the Ethernet unit, select [Yes] for the [Batch Readout of Multiple Blocks] setting.
 - When connecting to the built-in Ethernet port on the QnU series, select [Yes] for the [Random Readout] setting.

When connecting to the Ethernet unit

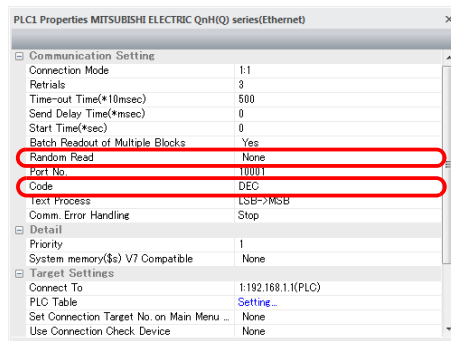

When connecting to the built-in Ethernet port on the QnU series

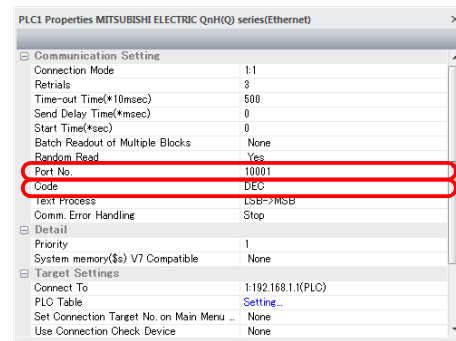

- IP address and port number of the PLC
Register on the PLC table in [System Setting] → [Hardware Setting] → [PLC Properties] → [Target Settings].

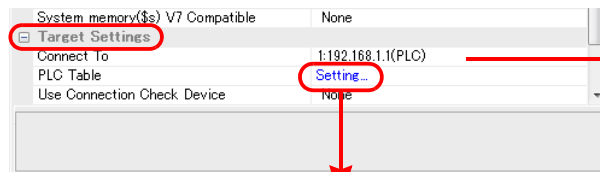

Valid only for 1 : 1 connection
Select the PLC for connection from those registered on the PLC table.

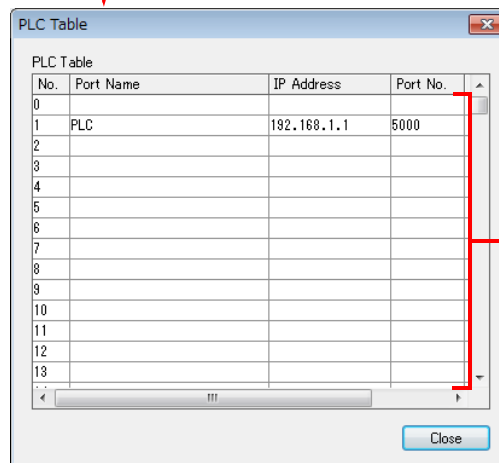

Set the IP address, port number and whether or not to use the KeepAlive function of the PLC.

PLC

Make the PLC setting using the programming tool "GX-Developer". For more information, refer to the PLC manual issued by the manufacturer.

Ethernet unit

PC parameter

Make the I/O assignment setting for the Ethernet unit.

Network parameter (Ethernet)

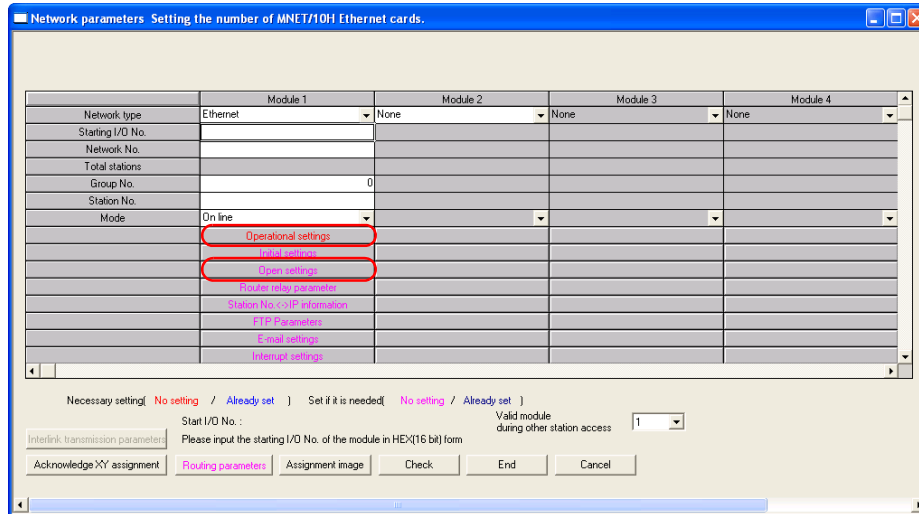

Item	Setting	Remarks
Network type	Ethernet	For more information, refer to the manual of the PLC.
Station I/O No.	Make settings in accordance with the network environment.	
Network No.		
Group No.		
Station No.		

Ethernet operations

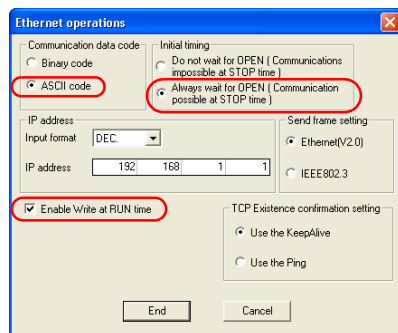

Item	Setting	Remarks
Communication data code	ASCII code	
Initial timing	Always wait for OPEN (Communication possible at STOP time)	
IP address (DEC)	Make settings in accordance with the network environment.	
Enable Write at RUN time	Checked	It is not possible to write value from V9 to PLC when unchecked. If so, "error code received 7167" occurs.

Open setting

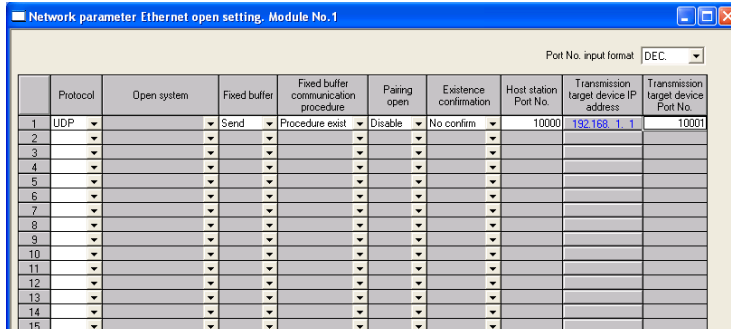

Item	Setting	Remarks
Protocol	UDP	
Host station Port No. (DEC)	Make settings in accordance with the network environment.	It is not possible to set it from No. 5000 to 5002.
Transmission target device IP address (DEC)	IP address of V9	
Transmission target device Port No. (DEC)	Port No. of V9	

Built-in Ethernet port

PC parameter

Make the settings for the IP address and the open settings in the [Built-in Ethernet port] tab window.

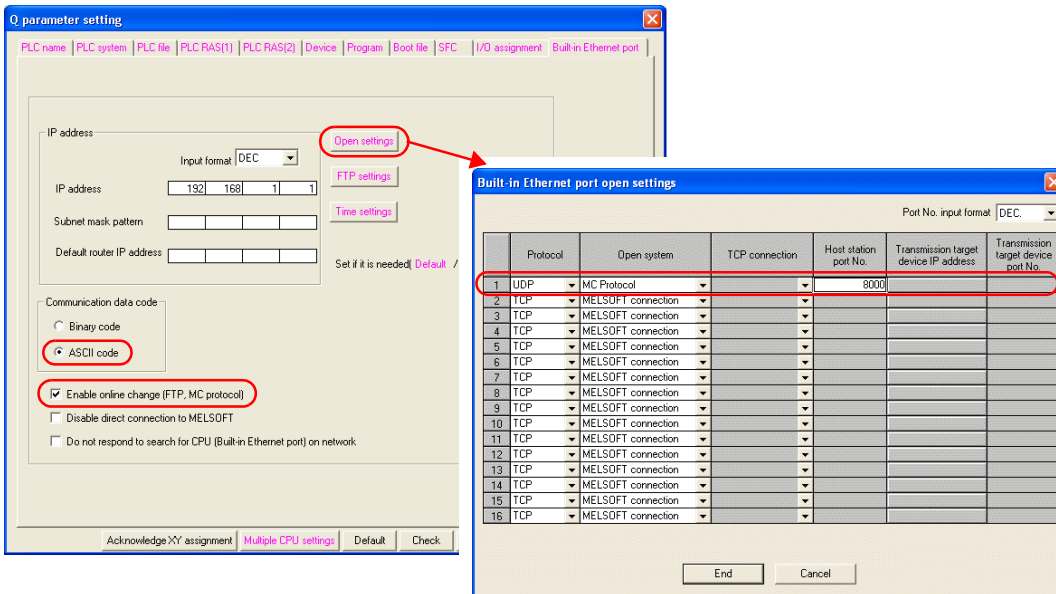

Item	Setting	Remarks
IP address (DEC)	Make settings in accordance with the network environment.	For more information, refer to the manual of the PLC.
Communication data code	ASCII code	
Enable online change (FTP, MC protocol)	Checked	It is not possible to write value from V9 to PLC when unchecked. If so, "error code received 7167" occurs.
Protocol	UDP	
Open system	MC Protocol	
Host station port No. (DEC)	Make settings in accordance with the network environment.	It is not possible to set it from No. 5000 to 5009.

Available Device Memory

The available setting range of device memory varies depending on the PLC model. Be sure to set within the range available for the PLC to be used. Use [TYPE] when assigning indirect device memory for macro programs.

Device Memory	TYPE	Remarks
D (data register)	00H	
W (link register)	01H	
R (file register)	02H	
TN (timer/current value)	03H	
CN (counter/current value)	04H	
SPU (special unit buffer memory)	05H	Invalid on QnU series Built-in port ^{*1}
M (internal relay)	06H	
L (latch relay)	07H	
B (link relay)	08H	
X (input)	09H	
Y (output)	0AH	
TS (timer/contact)	0BH	Invalid on QnU series Built-in port
TC (timer/coil)	0CH	Invalid on QnU series Built-in port
CS (counter/contact)	0DH	Invalid on QnU series Built-in port
CC (counter/coil)	0EH	Invalid on QnU series Built-in port
H (link unit buffer memory)	0FH	Invalid on QnU series Built-in port
SD (special register)	10H	
SM (special relay)	11H	
SB (special link relay)	12H	
SW (special link register)	13H	
ZR (file register (for continuous access))	14H	
F (annunciator)	15H	
SS (totalizing timer/contact)	16H	
SC (totalizing timer/coil)	17H	
SN (totalizing timer/current value)	18H	
Z (index register)	19H	

*1 The unit number is required in addition to the device type and address. Convert byte address into word address when entering the data on the editor if the memory device of the link unit is byte address. For the unit number, set the decimal number of "XXX" included in the station I/O number "xxx0 H" of the link unit. For more information, see page 9-16.

9.1.15 QnH (Q) Series (Multi-CPU) (Ethernet ASCII)

The communication setting and available device memory are the same as those described in "9.1.14 QnH (Q) Series (Ethernet ASCII)".

9.1.16 QnU Series (Built-in Ethernet)

Communication Setting

Editor

Make the following settings on the editor. For more information, see "1.3.2 Ethernet Communication".

- IP address for the V9 unit
 - When specified on the screen program:
[System Setting] → [Hardware Setting] → [Local Port IP Address]
 - When specified on the V9 unit:
Local mode → [LAN Setting]
- Port number for the V9 unit (for communication with PLC)
[System Setting] → [Hardware Setting] → [PLC Properties] → [Communication Setting]

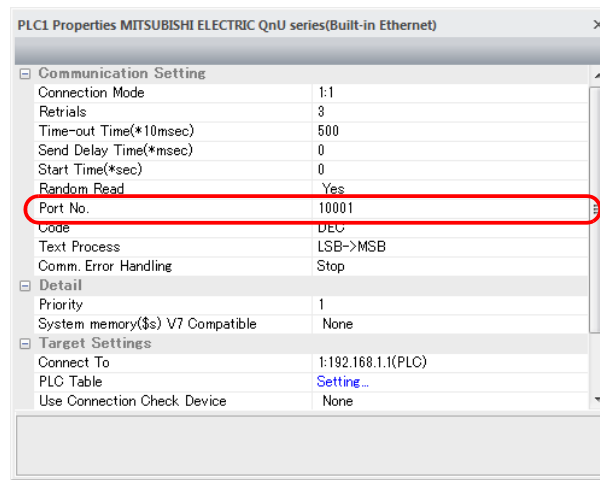

- IP address and port number of the PLC
Register on the [PLC Table] in [System Setting] → [Hardware Setting] → [PLC Properties] → [Target Settings].

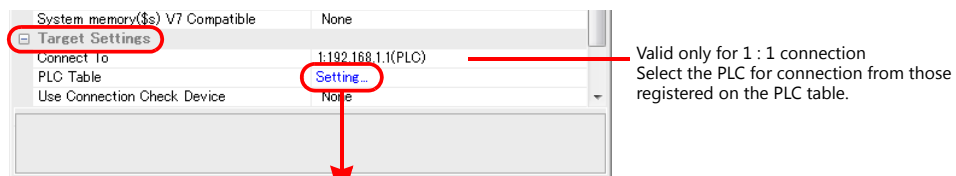

Valid only for 1:1 connection
Select the PLC for connection from those registered on the PLC table.

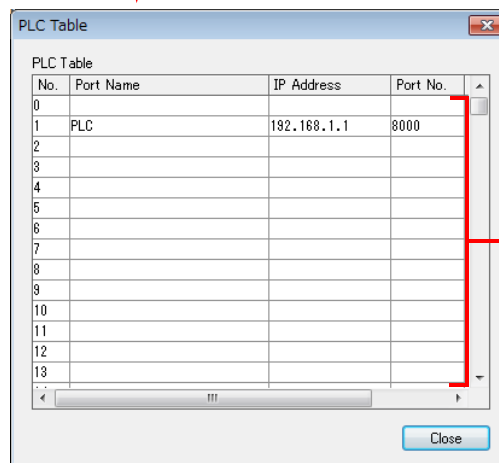

Set the IP address, port number and whether or not to use the KeepAlive function of the PLC.

PLC

Make the PLC setting using the programming tool "GX-Developer". For more information, refer to the PLC manual issued by the manufacturer.

QnU Series Built-in Ethernet

PC parameter

Make the settings for the IP address and the open settings in the Built-in Ethernet port tab window.

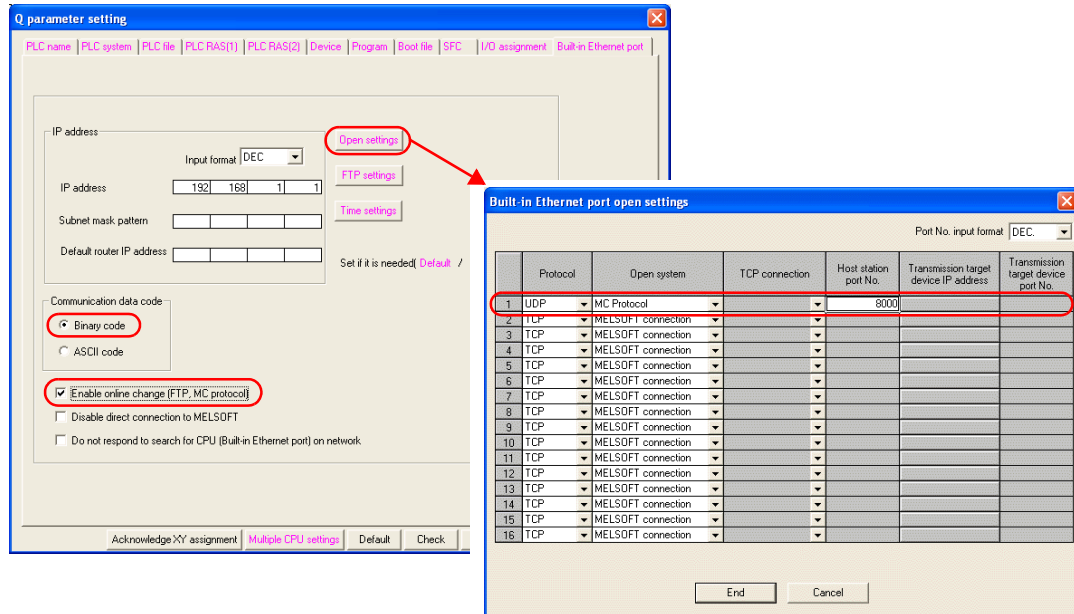

Item	Setting	Remarks
IP address (DEC)	Make settings in accordance with the network environment.	For more information, refer to the manual of the PLC.
Communication data code	Binary code	
Enable online change (FTP, MC protocol)	Checked	It is not possible to write value from V9 to PLC when unchecked. If so, "error code received 7167" occurs.
Protocol	UDP/TCP	Set the same protocol as the one set on the editor.
Open system	MC Protocol	
Host station port No. (DEC)	Make settings in accordance with the network environment.	It is not possible to set it from No. 5000 to 5009.

Available Device Memory

The available setting range of device memory varies depending on the PLC model. Be sure to set within the range available for the PLC to be used. Use [TYPE] when assigning indirect device memory for macro programs.

Device Memory	TYPE	Remarks
D (data register)	00H	
W (link register)	01H	
R (file register)	02H	
TN (timer/current value)	03H	
CN (counter/current value)	04H	
M (internal relay)	06H	
L (latch relay)	07H	
B (link relay)	08H	
X (input)	09H	
Y (output)	0AH	
TS (timer/contact)	0BH	
TC (timer/coil)	0CH	
CS (counter/contact)	0DH	
CC (counter/coil)	0EH	
SD (special register)	10H	
SM (special relay)	11H	
SB (special link relay)	12H	
SW (special link register)	13H	
ZR (file register (for continuous access))	14H	
F (annunciator)	15H	
SS (totalizing timer/contact)	16H	
SC (totalizing timer/coil)	17H	
SN (totalizing timer/current value)	18H	
Z (index register)	19H	

9.1.17 L Series Link

Communication Setting

Editor

Communication setting

(Underlined setting: default)

Item	Setting	Remarks
Connection Mode	<u>1</u> : 1 / 1 : n / Multi-link2 / Multi-link2 (Ethernet) / 1 : n Multi-link2 (Ethernet)	
Signal Level	<u>RS-232C</u> / RS-422/485	
Baud Rate	4800 / 9600 / 19200 / 38400 / 57600 / <u>115K</u> bps	
Data Length	<u>8</u> bits	
Stop Bit	<u>1</u> / 2 bits	
Parity	None / Odd / <u>Even</u>	
Target Port No.	<u>0</u> to 31	

PLC (PC Parameter)

Switch setting for I/O and intelligent function module

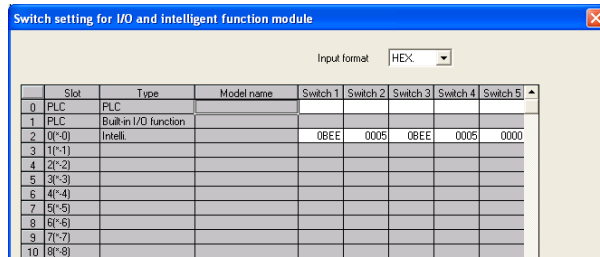

Switch	Contents	Example																																																		
Switch 1	<p>CH1: baud rate, transmission setting</p> <p>Bit 15 - 8 7 - 0</p> <p>Baud rate Transmission setting</p> <table border="1"> <thead> <tr> <th>bps</th> <th>Setting</th> </tr> </thead> <tbody> <tr><td>4800</td><td>04H</td></tr> <tr><td>9600</td><td>05H</td></tr> <tr><td>19200</td><td>07H</td></tr> <tr><td>38400</td><td>09H</td></tr> <tr><td>57600</td><td>0AH</td></tr> <tr><td>115200</td><td>0BH</td></tr> </tbody> </table> <table border="1"> <thead> <tr> <th>Bit</th> <th>Contents</th> <th>OFF</th> <th>ON</th> </tr> </thead> <tbody> <tr><td>0</td><td>Operation</td><td>Independent</td><td>Link</td></tr> <tr><td>1</td><td>Data bit</td><td>7</td><td>8</td></tr> <tr><td>2</td><td>Parity bit</td><td>Not provided</td><td>Provided</td></tr> <tr><td>3</td><td>Parity</td><td>Odd</td><td>Even</td></tr> <tr><td>4</td><td>Stop bit</td><td>1</td><td>2</td></tr> <tr><td>5</td><td>Sum check</td><td>Not provided</td><td>Provided</td></tr> <tr><td>6</td><td>Write while running</td><td>Prohibited</td><td>Allowed</td></tr> <tr><td>7</td><td>Setting change</td><td>Prohibited</td><td>Allowed</td></tr> </tbody> </table>	bps	Setting	4800	04H	9600	05H	19200	07H	38400	09H	57600	0AH	115200	0BH	Bit	Contents	OFF	ON	0	Operation	Independent	Link	1	Data bit	7	8	2	Parity bit	Not provided	Provided	3	Parity	Odd	Even	4	Stop bit	1	2	5	Sum check	Not provided	Provided	6	Write while running	Prohibited	Allowed	7	Setting change	Prohibited	Allowed	<p>OBEEH</p> <p>115 kbps 8 bits 1 bit Even</p>
bps	Setting																																																			
4800	04H																																																			
9600	05H																																																			
19200	07H																																																			
38400	09H																																																			
57600	0AH																																																			
115200	0BH																																																			
Bit	Contents	OFF	ON																																																	
0	Operation	Independent	Link																																																	
1	Data bit	7	8																																																	
2	Parity bit	Not provided	Provided																																																	
3	Parity	Odd	Even																																																	
4	Stop bit	1	2																																																	
5	Sum check	Not provided	Provided																																																	
6	Write while running	Prohibited	Allowed																																																	
7	Setting change	Prohibited	Allowed																																																	
Switch 2	CH1: communication protocol	MC protocol mode 5 binary code																																																		
Switch 3	CH2: baud rate, transmission setting (the same as those for switch 1)	OBEEH																																																		
Switch 4	CH2: communication protocol	MC protocol mode 5 binary code																																																		
Switch 5	Station number setting	0 to 31																																																		

Available Device Memory

The available setting range of device memory varies depending on the PLC model. Be sure to set within the range available for the PLC to be used. Use [TYPE] when assigning indirect device memory for macro programs.

Device Memory	TYPE	Remarks
D (data register)	00H	
W (link register)	01H	
R (file register)	02H	
TN (timer/current value)	03H	
CN (counter/current value)	04H	
SPU (special unit buffer memory)	05H	*1
M (internal relay)	06H	
L (latch relay)	07H	
B (link relay)	08H	
X (input)	09H	
Y (output)	0AH	
TS (timer/contact)	0BH	
TC (timer/coil)	0CH	
CS (counter/contact)	0DH	
CC (counter/coil)	0EH	
H (link unit buffer memory)	0FH	
SD (special register)	10H	
SM (special relay)	11H	
SB (special link relay)	12H	
SW (special link register)	13H	
ZR (file register (for continuous access))	14H	
F (annunciator)	15H	
SS (totalizing timer/contact)	16H	
SC (totalizing timer/coil)	17H	
SN (totalizing timer/current value)	18H	
Z (index register)	19H	

*1 The unit number is required in addition to the device type and address. To set the device memory address on the editor for the link unit which has byte-addressable memory, convert the address into word address.
For the unit number, set the decimal number of "XXX" included in the station I/O number "xxx0 H" of the link unit. For more information, refer to page 9-16.

9.1.18 L Series (Built-in Ethernet)

Communication Setting

Editor

Make the following settings on the editor. For more information, see "1.3.2 Ethernet Communication".

- IP address for the V9 unit
 - When specified on the screen program:
[System Setting] → [Hardware Setting] → [Local Port IP Address]
 - When specified on the V9 unit:
Local mode → [LAN Setting]
- Port numbers 1024 to 65000 for the V9 unit (for communication with PLC)
[System Setting] → [Hardware Setting] → [PLC Properties] → [Communication Setting]

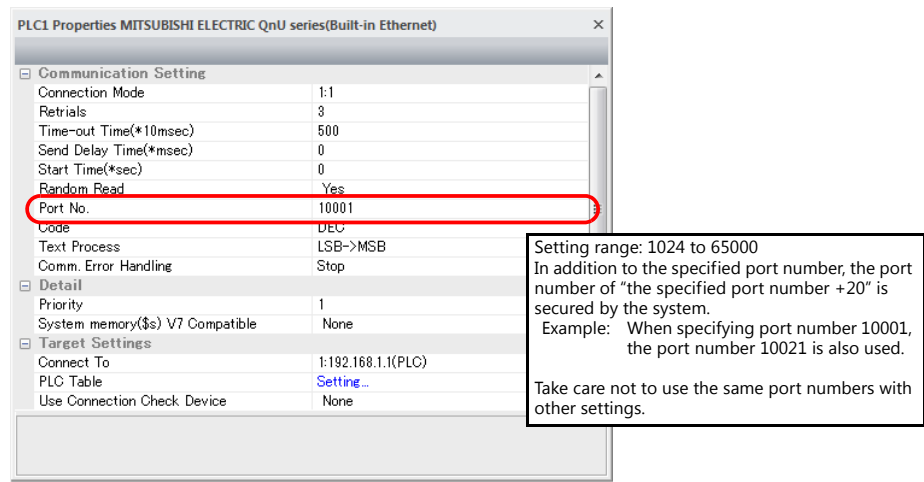

- IP address and port number of the PLC
Register on the [PLC Table] in [System Setting] → [Hardware Setting] → [PLC Properties] → [Target Settings].

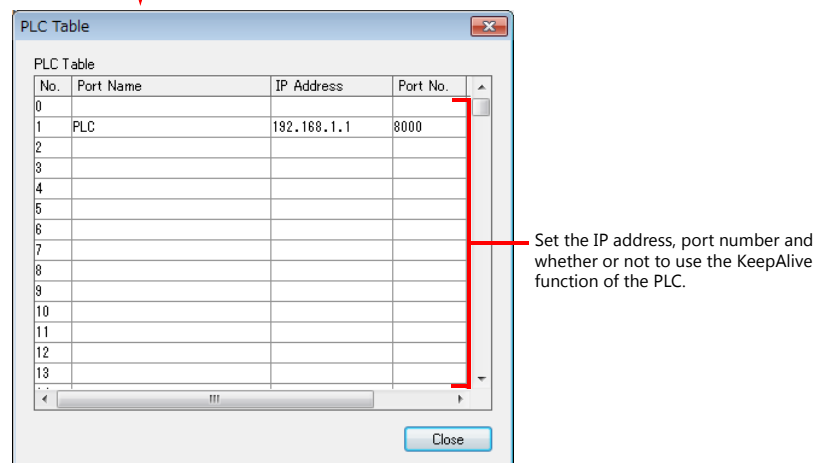
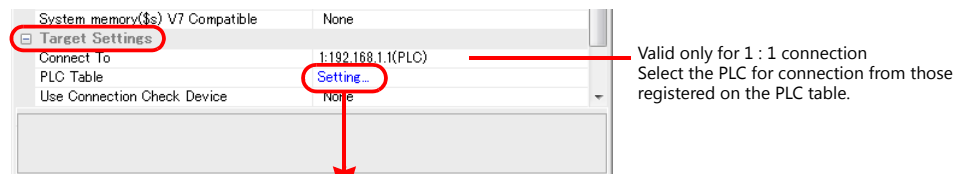

PLC

Make the PLC setting using the programming tool "GX-Developer". For more information, refer to the PLC manual issued by the manufacturer.

L Series Built-in Ethernet

Make the settings for the IP address and the open settings in the Built-in Ethernet port tab window.

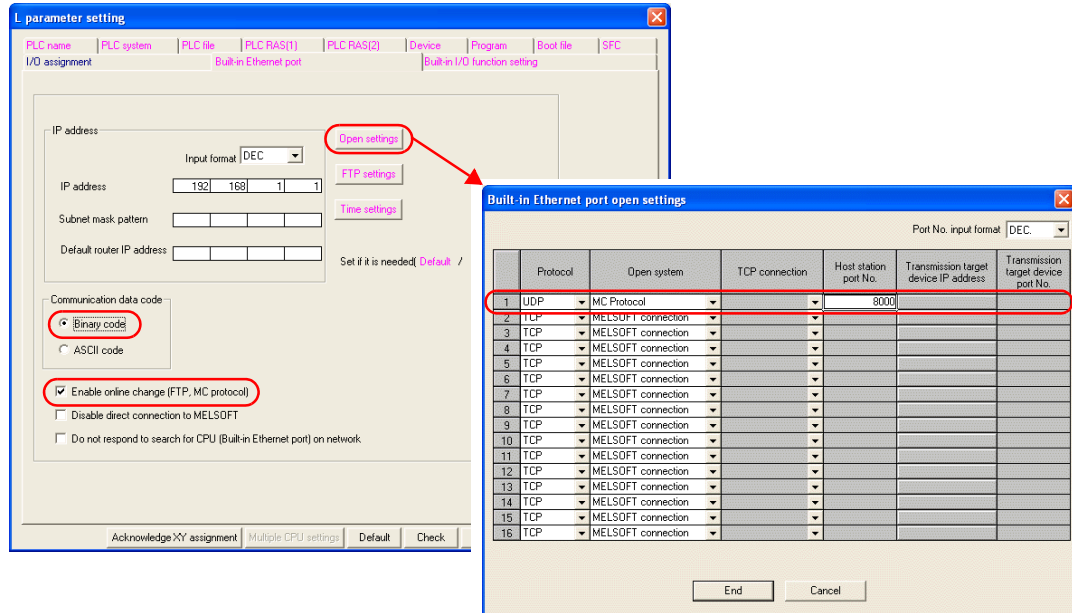

Item	Setting	Remarks
IP address (DEC)	Make settings in accordance with the network environment.	For more information, refer to the manual of the PLC.
Communication data code	Binary code	
Enable online change (FTP, MC protocol)	Checked	It is not possible to write value from V9 to PLC when unchecked. If so, "error code received 7167" occurs.
Protocol	UDP/TCP	Set the same protocol as the one set on the editor.
Open system	MC Protocol	
Host station port No. (DEC)	Make settings in accordance with the network environment.	It is not possible to set it from No.5000 to 5009.

Available Device Memory

The available setting range of device memory varies depending on the PLC model. Be sure to set within the range available for the PLC to be used. Use [TYPE] when assigning indirect device memory for macro programs.

Device Memory	TYPE	Remarks
D (data register)	00H	
W (link register)	01H	
R (file register)	02H	
TN (timer/current value)	03H	
CN (counter/current value)	04H	
SPU (special unit buffer memory)	05H	*1, not accessible when using CU-03-3
M (internal relay)	06H	
L (latch relay)	07H	
B (link relay)	08H	
X (input)	09H	
Y (output)	0AH	
TS (timer/contact)	0BH	
TC (timer/coil)	0CH	
CS (counter/contact)	0DH	
CC (counter/coil)	0EH	
SD (special register)	10H	
SM (special relay)	11H	
SB (special link relay)	12H	
SW (special link register)	13H	
ZR (file register (for continuous access))	14H	
F (annunciator)	15H	
SS (totalizing timer/contact)	16H	
SC (totalizing timer/coil)	17H	
SN (totalizing timer/current value)	18H	
Z (index register)	19H	

*1 The unit number is required in addition to the device type and address. To set the device memory address on the editor for the link unit which has byte-addressable memory, convert the address into word address. For the unit number, set the decimal number of "XXX" included in the station I/O number "xxx0 H" of the link unit. For more information, refer to page 9-16.

Accessing the SPU device memory from the V9 series

Add [Open system: MELSOFT connection] on the [Built-in Ethernet port open settings] dialog.
Add one port per one V9 series unit. (maximum 8 ports can be registered)

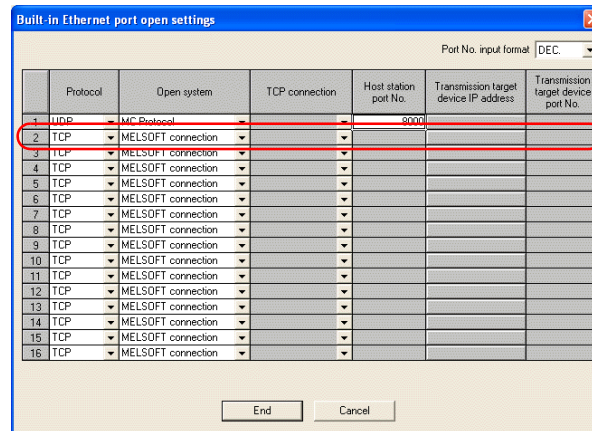

Item	Setting	Remarks
Protocol	TCP	
Open system	MELSOFT connection	

* Since TCP/IP communication is used, CU-03-3 is not available.

9.1.19 FX Series CPU

Communication Setting

Editor

Communication setting

(Underlined setting: default)

Item	Setting	Remarks
Connection Mode	<u>1:1</u> / Multi-link2 / Multi-link2 (Ethernet)	
Signal Level	RS-422/485	
Baud Rate	9600 bps	
Data Length	7 bits	
Stop Bit	1 bit	
Parity	Even	
Target Port No.	<u>0</u> to 31	

PLC

No particular setting is necessary on the PLC.

Available Device Memory

The available setting range of device memory varies depending on the PLC model. Be sure to set within the range available for the PLC to be used. Use [TYPE] when assigning indirect device memory for macro programs.

Device Memory	TYPE	Remarks
D (data register)	00H	D0 to 999, D8000 or later (special register)
TN (timer/current value)	01H	
CN (counter/current value)	02H	
32CN (32-bit counter/current value)	03H	Double word ^{*1} FX0N : C235 to 254, read only
M (auxiliary relay)	04H	FX1 : M0 to 1023, M8000 or later (special relay) FX2 : M0 to 1535, M8000 or later (special relay)
S (state)	05H	
X (input relay)	06H	Read only
Y (output relay)	07H	
TS (timer/contact)	08H	
CS (counter/contact)	09H	
DX (file register)	0AH	Use DX for D1000 to 2999.

*1 For items where double-words can be used (Num. Display, Graph, Sampling), data is processed as double-words.
For those where bits or words can be used, data is processed as words consisting of lower 16 bits.
For input: Upper 16 bits are ignored.
For output: "0" is written for upper 16 bits.

9.1.20 FX2N/1N Series CPU

Communication Setting

Editor

Communication setting

(Underlined setting: default)

Item	Setting	Remarks
Connection Mode	<u>1:1</u> / Multi-link2 / Multi-link2 (Ethernet)	
Signal Level	RS-422/485	
Baud Rate	9600 / 19200 / <u>38400</u> bps	
Data Length	7 bits	
Stop Bit	1 bit	
Parity	Even	
Target Port No.	<u>0</u> to 31	

PLC

No particular setting is necessary on the PLC.

Available Device Memory

The available setting range of device memory varies depending on the PLC model. Be sure to set within the range available for the PLC to be used. Use [TYPE] when assigning indirect device memory for macro programs.

Device Memory	TYPE	Remarks
D (data register)	00H	D8000 and later: special register
TN (timer/current value)	01H	
CN (counter/current value)	02H	
32CN (32-bit counter/current value)	03H	*1
M (auxiliary relay)	04H	M8000 and later: special relay
S (state)	05H	
X (input relay)	06H	Read only
Y (output relay)	07H	
TS (timer/contact)	08H	
CS (counter/contact)	09H	

*1 For items where double-words can be used (Num. Display, Graph, Sampling), data is processed as double-words.
 For those where bits or words can be used, data is processed as words consisting of lower 16 bits.
 For input: Upper 16 bits are ignored.
 For output: "0" is written for upper 16 bits.

9.1.21 FX1S Series CPU

Communication Setting

Editor

Communication setting

(Underlined setting: default)

Item	Setting	Remarks
Connection Mode	<u>1:1</u> / Multi-link2 / Multi-link2 (Ethernet)	
Signal Level	RS-422/485	
Baud Rate	9600 bps	
Data Length	7 bits	
Stop Bit	1 bit	
Parity	Even	
Target Port No.	<u>0</u> to 31	

PLC

No particular setting is necessary on the PLC.

Available Device Memory

The available setting range of device memory varies depending on the PLC model. Be sure to set within the range available for the PLC to be used. Use [TYPE] when assigning indirect device memory for macro programs.

Device Memory	TYPE	Remarks
D (data register)	00H	D0 to 255, D8000 or later (special register)
TN (timer/current value)	01H	
CN (counter/current value)	02H	
32CN (32-bit counter/current value)	03H	Double word *1
M (auxiliary relay)	04H	M0 to 511, M8000 or later (special relay)
S (state)	05H	
X (input relay)	06H	Read only
Y (output relay)	07H	
TS (timer/contact)	08H	
CS (counter/contact)	09H	
DX (file register)	0AH	Use DX for D1000 to 2999.

*1 For items where double-words can be used (Num. Display, Graph, Sampling), data is processed as double-words.
 For those where bits or words can be used, data is processed as words consisting of lower 16 bits.
 For input: Upper 16 bits are ignored.
 For output: "0" is written for upper 16 bits.

9.1.22 FX Series Link (A Protocol)

Communication Setting

Editor

Communication setting

(Underlined setting: default)

Item	Setting	Remarks
Connection Mode	<u>1:1</u> / 1:n / Multi-link / Multi-link2 / Multi-link2 (Ethernet) / 1:n Multi-link2 (Ethernet)	
Signal Level	<u>RS-232C</u> / RS-422/485	
Baud Rate	4800 / 9600 / <u>19200</u> bps	
Transmission Mode	<u>Transmission Mode 1</u> / Transmission Mode 4	
Data Length	<u>7</u> / 8 bits	
Stop Bit	<u>1</u> / 2 bits	
Parity	None / Odd / <u>Even</u>	
Target Port No.	<u>0</u> to 31	

PLC (PC Parameter)

PLC system (2)

(Underlined setting: default)

Item	Setting	Remarks
Operate communication setting	Checked	
Protocol	Dedicated protocol	
Data length	<u>7</u> bits / 8 bits	
Parity	None / <u>Odd</u> / Even	
Stop bit	<u>1</u> bit / 2 bits	
Transmission speed	4800 / <u>9600</u> / 19200 bps	
H/W type	<u>RS-232C</u> / RS-485	
Sum check	Checked	
Transmission control protocol	<u>Form 1</u> / Form 4	
Station number setting	<u>00</u> to 0FH	

- RS-232C
When you set Dedicated protocol, 7bits, Even, 1bit, 19200bps, sum check and form 1:
D8120 = 6896H
- RS-422
When you set Dedicated protocol, 7bits, Even, 1bit, 19200bps, sum check and form 1:
D8120 = 6096H

Available Device Memory

The available setting range of device memory varies depending on the PLC model. Be sure to set within the range available for the PLC to be used. Use [TYPE] when assigning indirect device memory for macro programs.

Device Memory	TYPE	Remarks
D (data register)	00H	D8000 and later: special register
TN (timer/current value)	01H	
CN (counter/current value)	02H	*1
32CN (32-bit counter/current value)	03H	*2
M (auxiliary relay)	04H	M8000 and later: special relay
S (state)	05H	
X (input relay)	06H	Read only
Y (output relay)	07H	
TS (timer/contact)	08H	
CS (counter/contact)	09H	

*1 CN200 to CN255 equals 32CN (32-bit counter).

*2 For items where double-words can be used (Num. Display, Graph, Sampling), data is processed as double-words.

For those where bits or words can be used, data is processed as words consisting of lower 16 bits.

For input: Upper 16 bits are ignored.

For output: "0" is written for upper 16 bits.

9.1.23 FX-3U/3UC/3G Series CPU

Communication Setting

Editor

Communication setting

(Underlined setting: default)

Item	Setting	Remarks
Connection Mode	<u>1:1</u> / Multi-link2 / Multi-link2 (Ethernet)	
Signal Level	RS-422/485	
Baud Rate	9600 / 19200 / 38400 / 57600 / <u>115K</u> bps	
Data Length	7 bits	
Stop Bit	1 bit	
Parity	Even	

PLC

No particular setting is necessary on the PLC.

Available Device Memory

The available setting range of device memory varies depending on the PLC model. Be sure to set within the range available for the PLC to be used. Use [TYPE] when assigning indirect device memory for macro programs.

Device Memory	TYPE	Remarks
D (data register)	00H	D8000 and later: special register
TN (timer/current value)	01H	
CN (counter/current value)	02H	
32CN (32-bit counter/current value)	03H	*1
M (auxiliary relay)	04H	M8000 and later: special relay
S (state)	05H	
X (input relay)	06H	Read only
Y (output relay)	07H	
TS (timer/contact)	08H	
CS (counter/contact)	09H	
R (extension register)	0BH	

*1 For items where double-words can be used (Num. Display, Graph, Sampling), data is processed as double-words.
 For those where bits or words can be used, data is processed as words consisting of lower 16 bits.
 For input Upper 16 bits are ignored.
 For output "0" is written for upper 16 bits.

9.1.24 FX-3U Series (Ethernet)

Communication Setting

Editor

Make the following settings on the editor. For more information, see "1.3.2 Ethernet Communication".

- IP address for the V9 unit
 - When specified on the screen program:
[System Setting] → [Hardware Setting] → [Local Port IP Address]
 - When specified on the V9 unit:
Local mode → [LAN Setting]
- Port number for the V9 unit (for communication with PLC)
[System Setting] → [Hardware Setting] → [PLC Properties] → [Communication Setting]

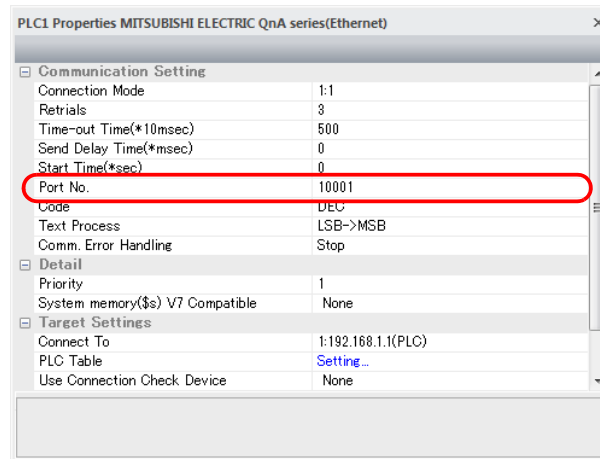

- IP address and port number of the PLC
Register on the [PLC Table] in [System Setting] → [Hardware Setting] → [PLC Properties] → [Target Settings].

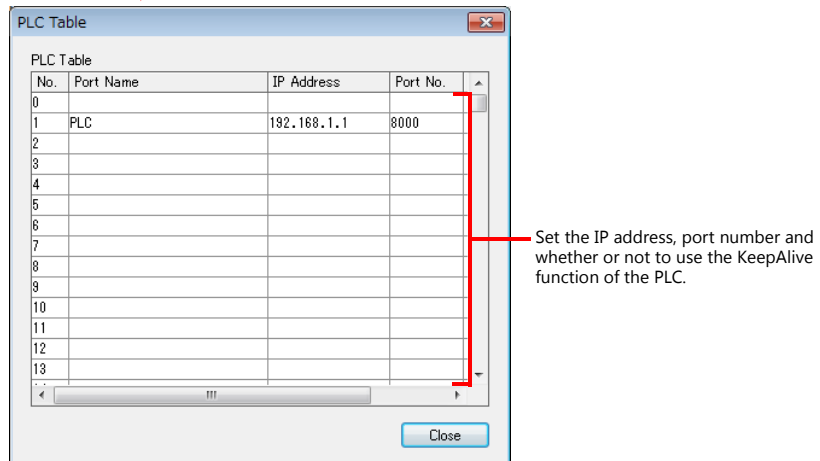
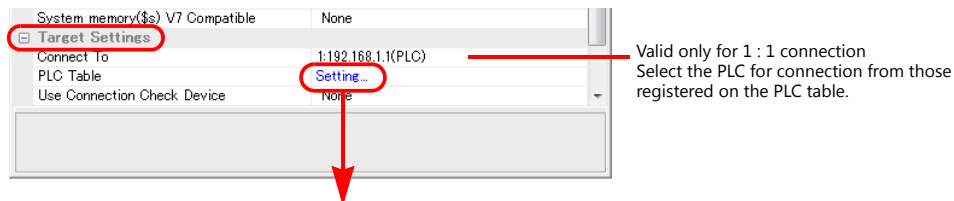

PLC

FX3U-ENET-L

Make PLC settings using the configuration tool "FX3U-ENET-L".

Ethernet operational settings

Item	Setting	Remarks
Communication data code	Binary code	
Initial timing	Always wait for OPEN (Communication possible at STOP time)	
IP address (DEC)	Specify according to the environment.	

Ethernet open settings

Use row No. 3 or No. 4 for setting.

Item	Setting	Remarks
Protocol	UDP	
Open system	MC protocol	
Existence confirmation	No confirm	
Host station Port No. (DEC)	As desired	1025 to 5548, 5552 to 65534
Transmission target device IP address	IP address of the V9	
Transmission target device Port No. (DEC)	Port number of the V9	

FX3U-ENET

Make the PLC setting using the programming tool "FX-Configurator-EN". For more information, refer to the PLC manual issued by the manufacturer.

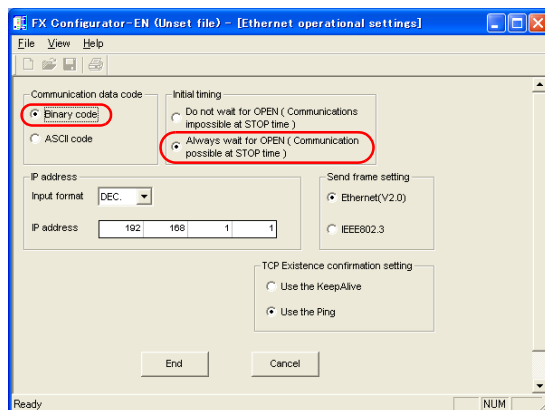
Ethernet operational settings

Item	Setting	Remarks
Communication data code	Binary code	
Initial timing	Always wait for OPEN (Communication possible at STOP time)	
IP address (DEC)	Make settings in accordance with the network environment.	

Open setting

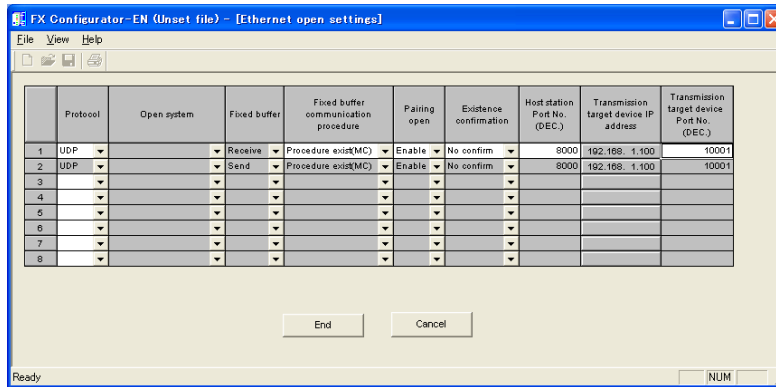

Item	Setting	Remarks
Protocol	UDP	
Fixed buffer	Receive, Send	
Fixed buffer communication procedure	Procedure exist (MC)	
Pairing open	Enable	
Existence confirmation	No confirm	
Host station Port No. (DEC)	Make settings in accordance with the network environment.	1025 to 5548, 5552 to 65534
Transmission target device IP address (DEC)	IP address of V9	
Transmission target device Port No. (DEC)	Port No. of V9	

Available Device Memory

The available setting range of device memory varies depending on the PLC model. Be sure to set within the range available for the PLC to be used. Use [TYPE] when assigning indirect device memory for macro programs.

Device Memory	TYPE	Remarks
D (data register)	00H	D8000 and later: special register
TN (timer/current value)	01H	
CN (counter/current value)	02H	
32CN (32-bit counter/current value)	03H	*1
M (auxiliary relay)	04H	M8000 and later: special relay
S (state)	05H	
X (input relay)	06H	Read only
Y (output relay)	07H	
TS (timer/contact)	08H	
CS (counter/contact)	09H	
R (extension register)	0BH	

*1 For items where double-words can be used (Num. Display, Graph, Sampling), data is processed as double-words. For those where bits or words can be used, data is processed as words consisting of lower 16 bits.
 For input Upper 16 bits are ignored.
 For output "0" is written for upper 16 bits.

9.1.25 FX 3U/3UC/3G Series Link (A Protocol)

Communication Setting

Editor

Communication setting

(Underlined setting: default)

Item	Setting	Remarks
Connection Mode	<u>1 : 1</u> / 1 : n / Multi-link / Multi-link2 / Multi-link2 (Ethernet) / 1 : n Multi-link2 (Ethernet)	
Signal Level	<u>RS-232C</u> / RS-422/485	
Baud Rate	4800 / 9600 / <u>19200</u> bps	
Transmission Mode	<u>Transmission Mode 1</u> / Transmission Mode 4	
Data Length	<u>7</u> / 8 bits	
Stop Bit	<u>1</u> / 2 bits	
Parity	None / Odd / <u>Even</u>	
Target Port No.	<u>0</u> to 31	

PLC (PC Parameter)

PLC system (2)

FX parameter

Memory capacity | Device | PLC name | I/O assignment | PLC system(1) | **PLC system(2)** | Positioning

CH1

Operate communication setting
If the box is not checked, the parameters will be cleared.
(When the program is transferred to the communication board, parameters and D8120 values in the PLC must be cleared upon program transfer.)

Protocol: Dedicated protocol Control line

Data length: 7bit H/W type: Regular/RS-232C

Parity: Odd Control mode: Invalid

Stop bit: 1bit Sum check

Transmission speed: 19200 (bps) Transmission control procedure: Form 1 (without CR,LF)

Header Station number setting: 00 H (00H-0FH)

Terminator Time out judge time: 1 x10ms (1-255)

Default Check End Cancel

(Underlined setting: default)

Item	Setting	Remarks
Operate communication setting	Checked	
Protocol	Dedicated protocol	
Data length	<u>7 bits</u> / 8 bits	
Parity	None / <u>Odd</u> / Even	
Stop bit	<u>1 bit</u> / 2 bits	
Transmission speed	4800 / <u>9600</u> / 19200 bps	
H/W type	<u>RS-232C</u> / RS-485	
Sum check	Checked	
Transmission control protocol	<u>Form 1</u> / Form 4	
Station number setting	<u>00</u> to 0FH	

- RS-232C
When you set Dedicated protocol, 7bits, Even, 1bit, 19200bps, sum check and form 1:
D8120 (D8420) = 6896H
- RS-422
When you set Dedicated protocol, 7bits, Even, 1bit, 19200bps, smacked and form 1:
D8120 (D8420) = 6096H

* CH1 : D8120, CH2 : D8420

Available Device Memory

The available setting range of device memory varies depending on the PLC model. Be sure to set within the range available for the PLC to be used. Use [TYPE] when assigning indirect device memory for macro programs.

Device Memory	TYPE	Remarks
D (data register)	00H	D8000 and later: special register
TN (timer/current value)	01H	
CN (counter/current value)	02H	
32CN (32-bit counter/current value)	03H	*1
M (auxiliary relay)	04H	M8000 and later: special relay
S (state)	05H	
X (input relay)	06H	Read only
Y (output relay)	07H	
TS (timer/contact)	08H	
CS (counter/contact)	09H	
R (extension register)	0BH	

*1 For items where double-words can be used (Num. Display, Graph, Sampling), data is processed as double-words.
 For those where bits or words can be used, data is processed as words consisting of lower 16 bits.
 For input: Upper 16 bits are ignored.
 For output: "0" is written for upper 16 bits.

9.1.26 A-Link + Net10

The A-link + Net10 can only be selected by the logical port PLC1.

The V9 series can communicate with an A series on the network (Net10) via the standard type link unit.

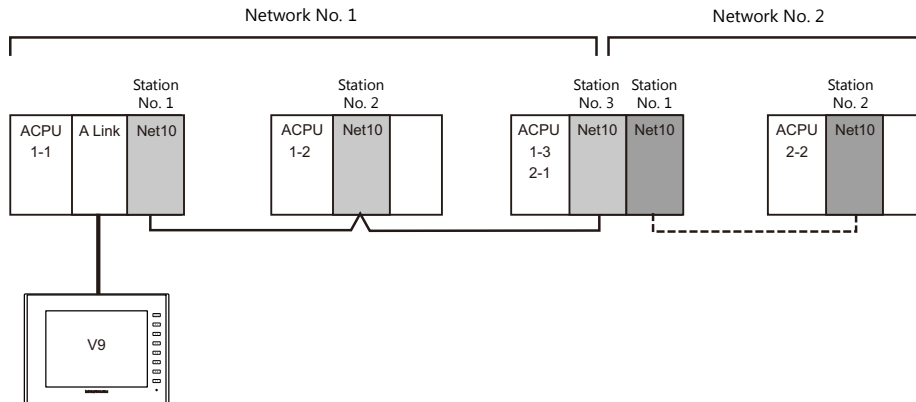

- When the V9 series is connected to a standard type link unit that is mounted on a CPU connected to a data-link system and network system, the V9 series can access other CPUs on NET II (/B) and NET/10. In such a case, select "A-Link + Net10" for the V-SFT PLC type.
- Accessing other CPUs on NET II (/B) and NET/10 with the V9 series
 - On NET II (/B), only CPUs on the same network as the CPU installed with the standard type link unit for connection with the V9 series (No.1 in above figure) can be accessed. (Available station numbers: 0 to 64)
 - On NET/10, CPUs on networks other than the network with the CPU installed with the standard type link unit for connection with the V9 series (No.1 in above figure) can be accessed as well (No.2 in above figure). (Available station numbers: 1 to 64)
- Reading and writing device memory for the CPU installed with the standard type link unit for connection with the V9 series (1-1 in above figure)
Set station number 31 for device memory settings on the V-SFT.
The response time becomes the same level as with connection between the V9 series and PLC (1 : 1).
 - * **Note that the response time is slow when writing and reading CPU device memory with station numbers other than "31" since transient transmission is used.**
 - * **Do not use station number "31" for PLCs on a network.**
- For details on NET II (/B) data link and NET/10 network systems, refer to instruction manuals issued by Mitsubishi.

Communication Setting

Editor

Communication setting

(Underlined setting: default)

Item	Setting	Remarks
Connection Mode	<u>1</u> : n	
Signal Level	<u>RS-232C</u> / RS-422/485	
Baud Rate	4800 / 9600 / <u>19200</u> bps	
Transmission Mode	<u>Transmission Mode 1</u> / Transmission Mode 4	Transmission Mode 1: Without CR/LF Transmission Mode 4: With CR/LF
Data Length	<u>7</u> / 8 bits	
Stop Bit	<u>1</u> / 2 bits	
Parity	None / Odd / <u>Even</u>	

PLC

For details on settings for NET II (/B) data link and NET/10 network systems, refer to instruction manuals issued by Mitsubishi.

Standard type link unit

Other than the station number, settings are the same as for "9.1.1 A Series Link".
Specify "0" for the station number.

Available Device Memory

The contents of "Available Device Memory" are the same as those described in "9.1.1 A Series Link".

When setting the device memory on the V-SFT, specify the station number as well.
Specify the network number using a macro. For more information, refer to the following.

Network specification macro

When accessing a PLC on a network number other than that directly connected via NET/10, execute "SYS (OUT_ENQ) F1" with the screen open macro, and specify the network number to connect to.

Station numbers on multiple networks cannot be accessed from the same screen.

Macro command "SYS (OUT_ENQ) F1"

Contents	F0	F1 (= \$u n)	
Network specification	OUT_ENQ	n	0 (fixed)
		n+1	2 (fixed)
		n+2	System code 1: NET/10 2: NET II (/B)
		n+3	Network No. (fixed to 0 when n+2=2)

Use this macro with the screen open macro. If used at any other time, a communication error will result since a network change takes place immediately.

For more information on macros, refer to the separate Macro Reference manual.

Also refer to "network registration" in the "Standard Link / Multi-drop Link Unit" manual from Mitsubishi.

9.1.27 Q170MCPU (Multi CPU)

Editor

Communication setting

(Underlined setting: default)

Item	Setting	Remarks
Connection Mode	<u>1:1</u> / Multi-link2 / Multi-link2 (Ethernet)	
Signal Level	RS-232C	
Baud Rate	9600 / 19200 / 38400 / 57600 / <u>115K</u> bps	
Data Length	8 bits	
Stop Bit	1 bit	
Parity	Odd	

PLC

When using the PLC for the first time, the operating system must be installed. For more information, refer to the PLC manual issued by the manufacturer.
No communication setting is required.

Available Device Memory

The available setting range of device memory varies depending on the PLC model. Be sure to set within the range available for the PLC to be used. Use [TYPE] when assigning indirect device memory for macro programs.

Device Memory	TYPE	Remarks
D (data register)	00H	
W (link register)	01H	
R (file register)	02H	Available only for the sequencer CPU
TN (timer/current value)	03H	Available only for the sequencer CPU
CN (counter/current value)	04H	Available only for the sequencer CPU
SPU (special unit buffer memory)	05H	Available only for the sequencer CPU *1
M (internal relay)	06H	
L (latch relay)	07H	Available only for the sequencer CPU
B (link relay)	08H	
X (input)	09H	
Y (output)	0AH	
TS (timer/contact)	0BH	Available only for the sequencer CPU
TC (timer/coil)	0CH	Available only for the sequencer CPU
CS (counter/contact)	0DH	Available only for the sequencer CPU
CC (counter/coil)	0EH	Available only for the sequencer CPU
SD (special register)	10H	
SM (special relay)	11H	
SB (special link relay)	12H	Available only for the sequencer CPU
SW (special link register)	13H	Available only for the sequencer CPU
ZR (file register/for continuous access)	14H	Available only for the sequencer CPU
F (annunciator)	15H	
SS (totalizing timer/contact)	16H	Available only for the sequencer CPU
SC (totalizing timer/coil)	17H	Available only for the sequencer CPU
SN (totalizing timer/current value)	18H	Available only for the sequencer CPU
Z (index register)	19H	Available only for the sequencer CPU
# (motion register)	1AH	Available only for the motion CPU

*1 The unit number is required in addition to the device type and address. To set the device memory address on the editor for the link unit which has byte-addressable memory, convert the address into word address.
For the unit number, set the decimal number of "XXX" included in the station I/O number "xxx0 H" of the link unit. For more information, see page 9-16.

Specifying the access CPU

In addition to the device type and address, an access CPU must be specified. The assigned device memory is expressed as shown below when editing the screen.

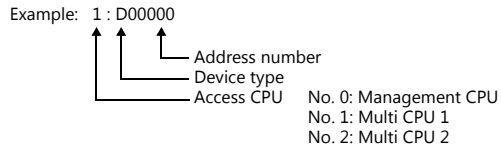

* Q170MCPU is equipped with the sequencer CPU and motion CPU in one unit.

The multi CPU unit No. is fixed as shown below:

Management CPU: Sequencer CPU
Multi CPU 1: Sequencer CPU
Multi CPU 2: Motion CPU

Indirect Device Memory Designation

- For the address number of 0 to 65535:

	15	8	7	0
n + 0	Model		Device type	
n + 1	Address No.			
n + 2	Expansion code *		Bit designation	
n + 3	00		Station number	

- For the address number of 65536 or greater:

	15	8	7	0
n + 0	Model		Device type	
n + 1	Lower address No.			
n + 2	Higher address No.			
n + 3	Expansion code *		Bit designation	
n + 4	00		Station number	

- * For the SPU device memory, specify the unit number in the expansion code.
For any other devices memory, specify the access CPU number in the expansion code.
Management CPU: 0 Multi CPU: 1 or 2

9.1.28 Q170 Series (Multi CPU) (Ethernet)

Communication Setting

Editor

Make the following settings on the editor. For more information, see "1.3.2 Ethernet Communication".

- IP address for the V9 unit
 - When specified on the screen program:
[System Setting] → [Hardware Setting] → [Local Port IP Address]
 - When specified on the V9 unit:
Local mode → [LAN Setting]
- Port number for the V9 unit (for communication with PLC)
[System Setting] → [Hardware Setting] → [PLC Properties] → [Communication Setting]

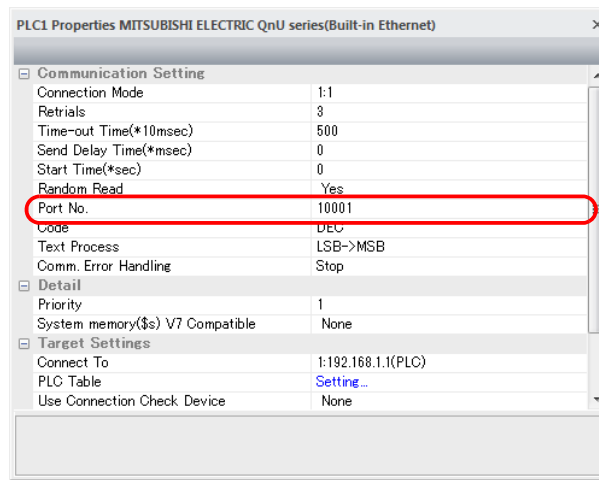

- IP address and port number of the PLC
Register on the [PLC Table] in [System Setting] → [Hardware Setting] → [PLC Properties] → [Target Settings].

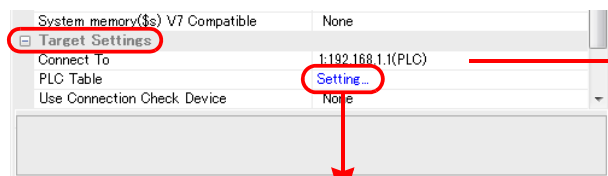

Valid only for 1 : 1 connection
Select the PLC for connection from those registered on the PLC table.

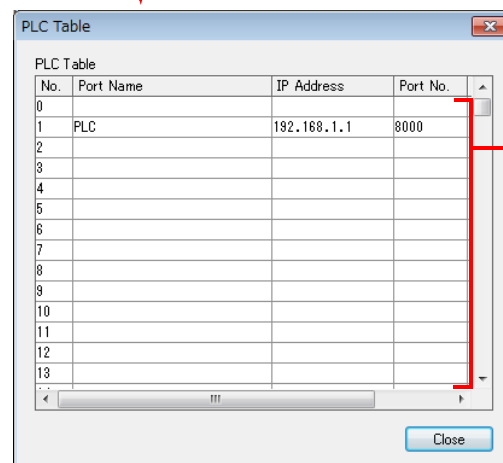

Set the IP address, port number and whether or not to use the KeepAlive function of the PLC.

On the MT Developer 2, the port number is specified in hexadecimal notation.
When specifying the port number on the editor, convert it into a decimal number.

PLC

When using the PLC for the first time, the operating system must be installed.
Make communication settings using the programming tool "MT-Developer2". For more information, refer to the PLC manual issued by the manufacturer.

Built-in Ethernet port setting

Specify the IP address and open method on the built-in Ethernet port setting dialog.

Item	Setting	Remarks
IP address (DEC)	Specify according to the environment.	For more information, refer to the manual of the PLC.
Communication data code	Binary code	
Enable writing during running	Checked	Data can be written from V9 to PLC only when this box is checked. If writing of data is attempted while the box is unchecked, the error "Error code received Receive code 7167" will occur.
Protocol	UDP/TCP	Set the same protocol as the one set on the editor.
Open type	MC protocol	
Local port No. (HEX)	Specify according to the environment.	1388H to 1391H cannot be specified because they are occupied by the system. When making a setting on the editor, convert the number specified here into a decimal number.

Calendar

Normally the calendar of the sequencer CPU, which is specified in the read or write area, is used.
However, if different numbers are specified in the read area and the write area, the calendar of the CPU specified in the read area is used.
If any device other than the sequencer CPU is specified in the read area and write area, the calendar of the smallest-numbered sequencer CPU is used.

Available Device Memory

The available setting range of device memory varies depending on the PLC model. Be sure to set within the range available for the PLC to be used. Use [TYPE] when assigning indirect device memory for macro programs.

Device Memory	TYPE	Remarks
D (data register)	00H	
W (link register)	01H	
R (file register)	02H	Available only for the sequencer CPU
TN (timer/current value)	03H	Available only for the sequencer CPU
CN (counter/current value)	04H	Available only for the sequencer CPU
M (internal relay)	06H	
L (latch relay)	07H	Available only for the sequencer CPU
B (link relay)	08H	
X (input)	09H	
Y (output)	0AH	
TS (timer/contact)	0BH	Available only for the sequencer CPU
TC (timer/coil)	0CH	Available only for the sequencer CPU
CS (counter/contact)	0DH	Available only for the sequencer CPU
CC (counter/coil)	0EH	Available only for the sequencer CPU
SD (special register)	10H	
SM (special relay)	11H	
SB (special link relay)	12H	Available only for the sequencer CPU
SW (special link register)	13H	Available only for the sequencer CPU
ZR (file register/for continuous access)	14H	Available only for the sequencer CPU
F (annunciator)	15H	
SS (totalizing timer/contact)	16H	Available only for the sequencer CPU
SC (totalizing timer/coil)	17H	Available only for the sequencer CPU
SN (totalizing timer/current value)	18H	Available only for the sequencer CPU
Z (index register)	19H	Available only for the sequencer CPU
# (motion register)	2AH	Available only for the motion CPU

Specifying the access CPU

In addition to the device type and address, an access CPU must be specified. The assigned device memory is expressed as shown below when editing the screen.

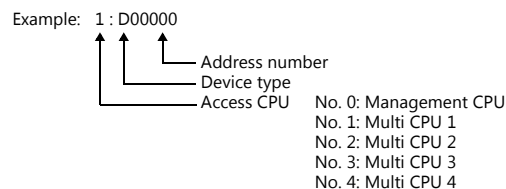

* The multi CPU unit numbers are assigned as shown below:

- For Q170MCPU

Management CPU: Motion CPU
Multi CPU 1: Sequencer CPU
Multi CPU 2: Motion CPU

- For Q172DCPU-S1/Q173DCPU-S1

Management CPU: Motion CPU
Multi CPU 1 to 4: Determined according to the slot position of the CPU

Indirect Device Memory Designation

- For the address number of 0 to 65535:

	15	8 7	0
n + 0	Model		Device type
n + 1	Address No.		
n + 2	Expansion code *		Bit designation
n + 3	00		Station number

- For the address number of 65536 or greater:

	15	8 7	0
n + 0	Model		Device type
n + 1	Lower address No.		
n + 2	Higher address No.		
n + 3	Expansion code *		Bit designation
n + 4	00		Station number

* Specify the access CPU number in the expansion code.
Management CPU: 0 Multi CPU: 1 or 4

9.1.29 Wiring Diagrams

When Connected at CN1:

RS-232C

Wiring diagram 1 - C2

Hakko Electronics' cable "D9-MI2-09-□M" (□ = 2, 3, 5, 10, 15)

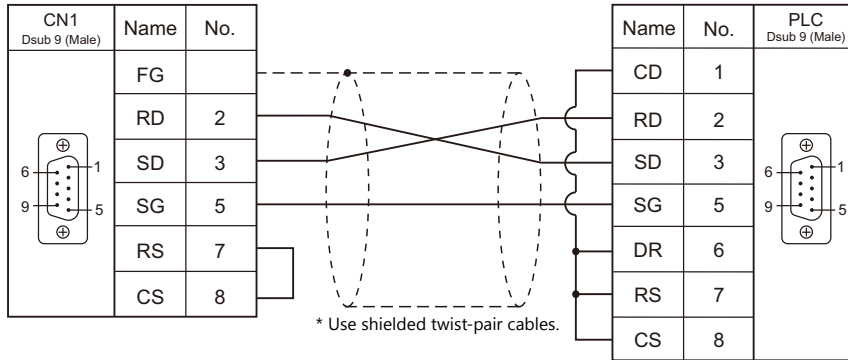

Wiring diagram 2 - C2

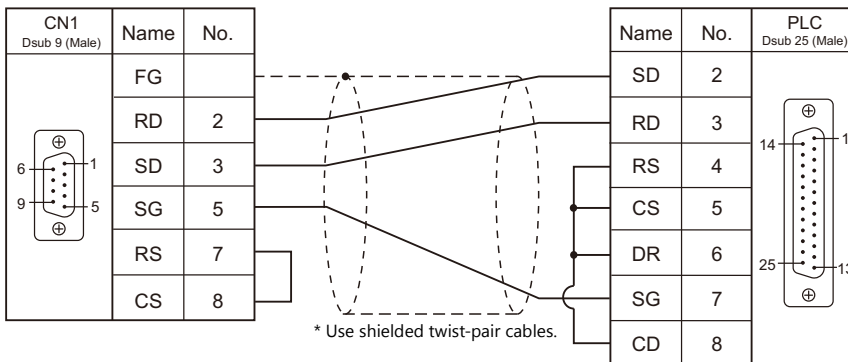

Wiring diagram 3 - C2

Hakko Electronics' cable "D9-MI2-FX2N-2M"

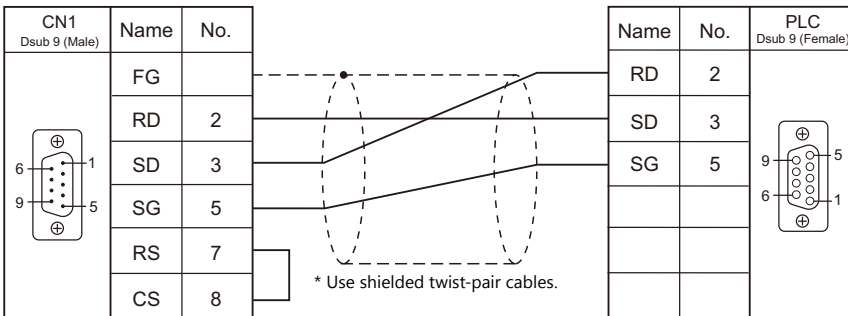

Wiring diagram 4 - C2

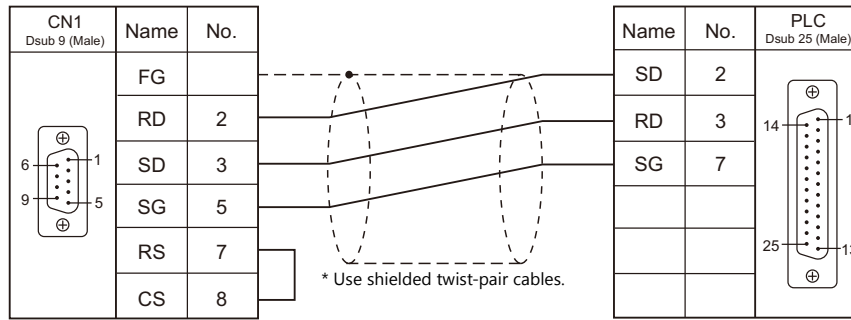

RS-422/RS-485

Wiring diagram 1 - C4

Hakko Electronics' cable "D9-MI4-0T-□M" (□ = 2, 3, 5, 10, 15)

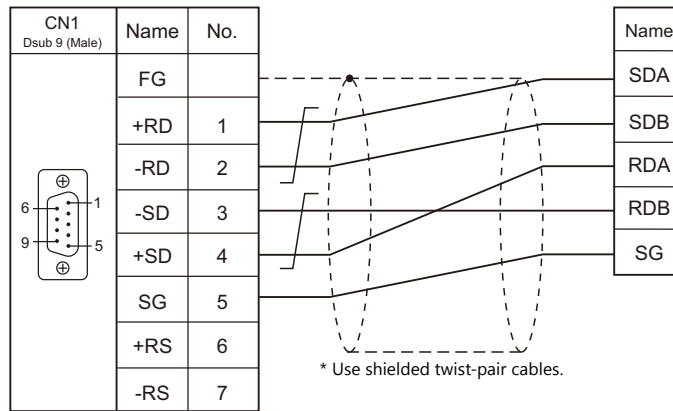

Wiring diagram 2 - C4

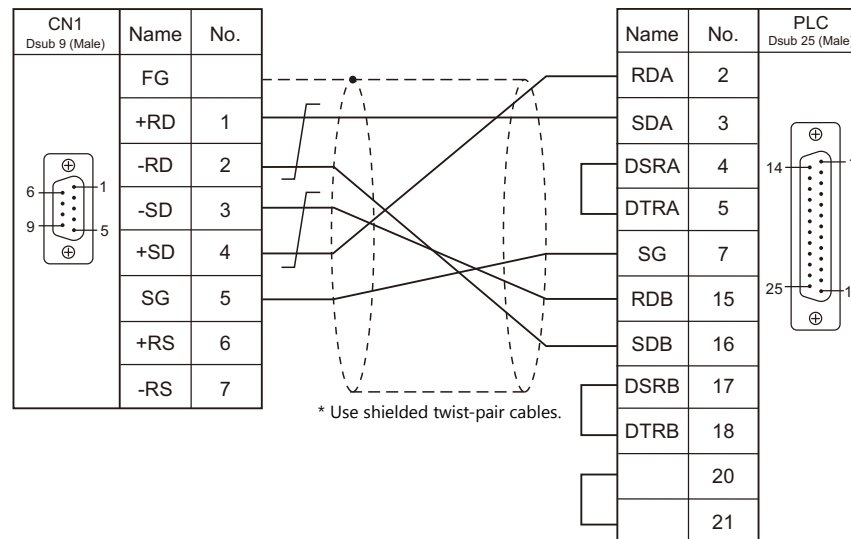

Wiring diagram 3 - C4

Hakko Electronics' cable "D9-MB-CPUQ-□M" (□ = 2, 3, 5, 10, 15)

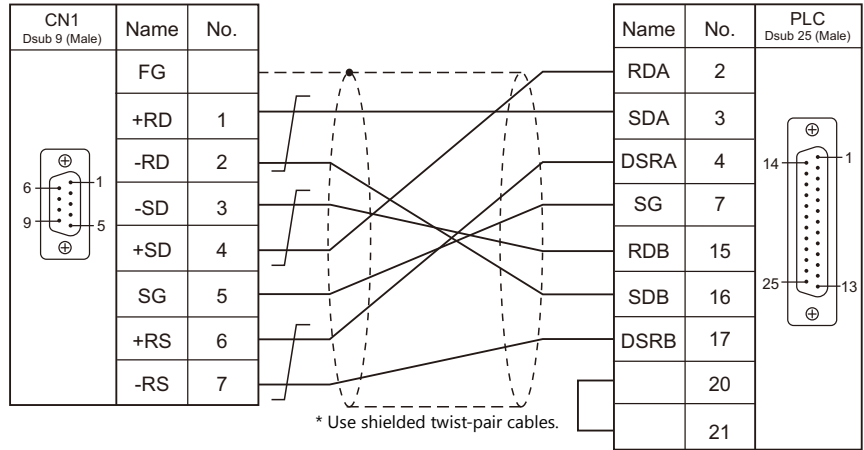

According to our noise tests, the attachment of a ferrite core improves noise voltage by 650 to 900 V and aids in preventing communication errors.

- When connecting to the A/QnA series CPU directly, attach a ferrite core to the communication cable to avoid noise problems.

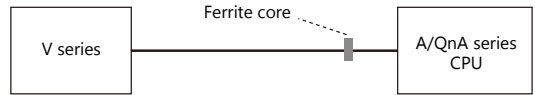

- Ferrite cores are optionally available. The model name is "GD-FC" (inner diameter: 8 mm, outer diameter: 20 mm).
- In consideration of such noise problems, it is recommended that the standard type link unit be used when the cable length of 15 m or longer is required.

When Connected at MJ1/MJ2:

RS-232C

Wiring diagram 1 - M2

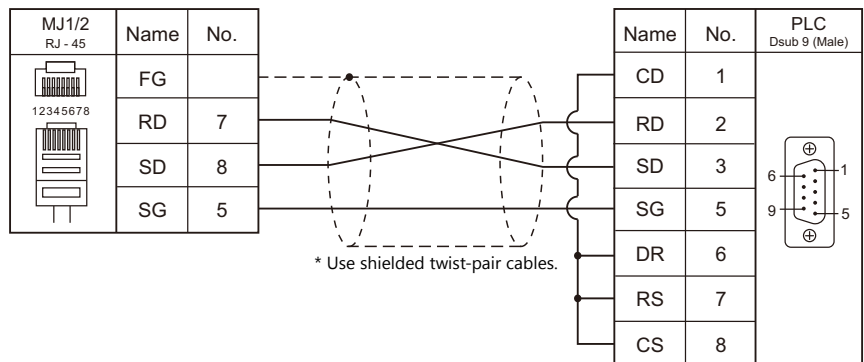

Wiring diagram 2 - M2

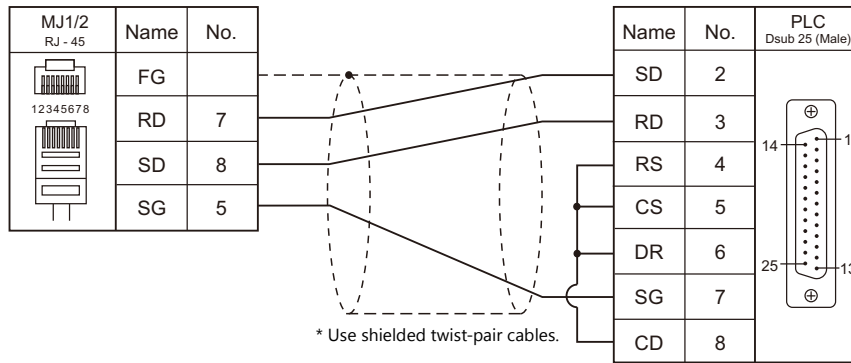

Wiring diagram 3 - M2

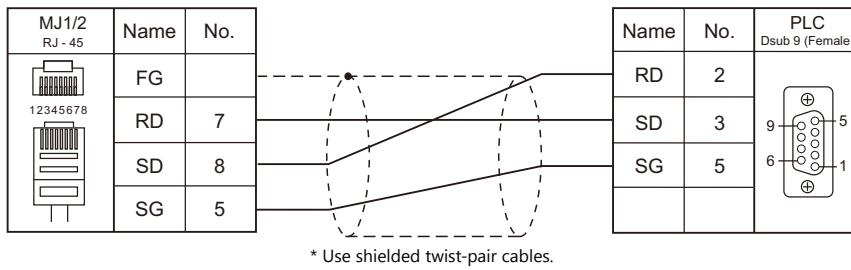

Wiring diagram 4 - M2

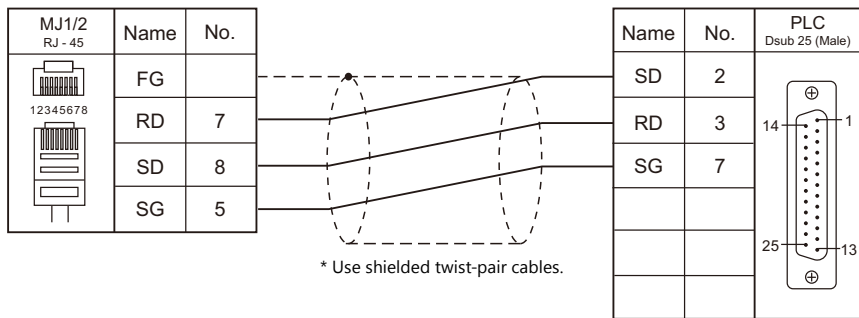

Wiring diagram 5 - M2

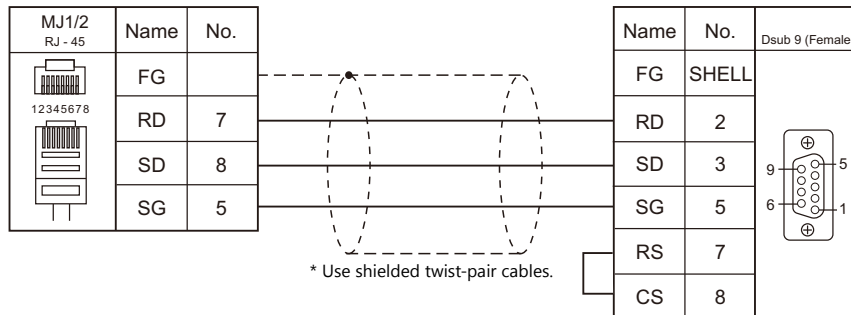

RS-422/RS-485

Wiring diagram 1 - M4

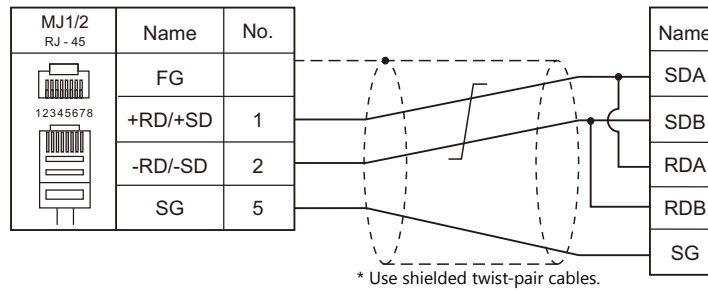

V-MDD (Dual Port Interface)

"V-MDD" is the add-on connector unit with two ports, specifically designed for Mitsubishi's A series, QnA series or FX series CPU programmer.

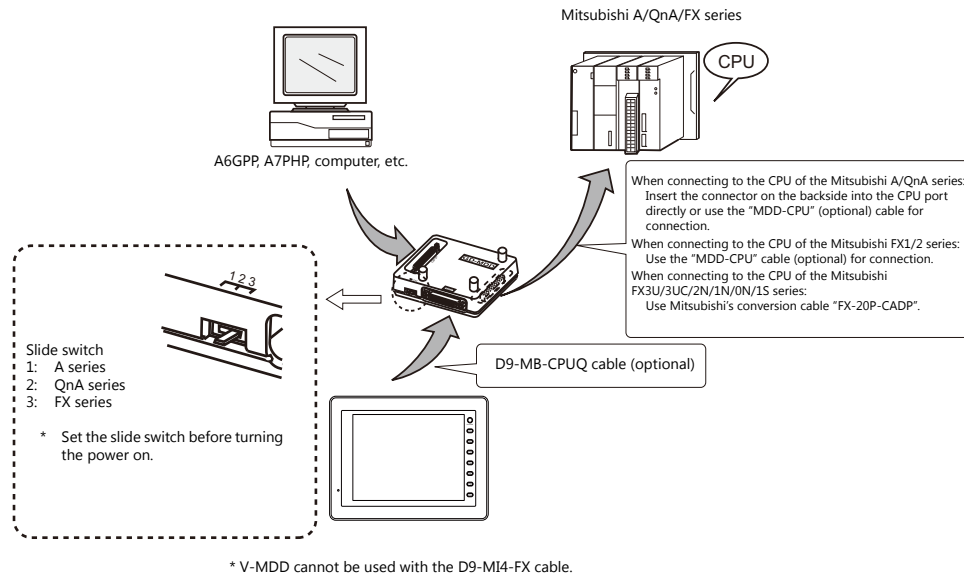

- The power to V-MDD is supplied from the CPU. Check the electric capacity of 5 V at the CPU. (Current consumption: max. 350 mA)
- Keep the cable between the CPU and V-MDD as short as possible. (Max. 1 to 1.5 m)
- Be sure to consider noise problems when performing wiring.
- When using V-MDD for connection with the V9 series, set 1.5 seconds or above for the timeout time in the [Communication Setting] dialog.
- Please read the instruction manual for V-MDD before use.
- When using V-MDD, set 9600 bps for the baud rate.

9.2 Temperature Controller/Servo/Inverter Connection

Inverter

PLC Selection on the Editor	Model	Port	Signal level	Connection		Lst File
				CN1	MJ1/MJ2	
FR-*500	FR-A500 FR-E500 FR-F500	PU connector	RS-485	Wiring diagram 1 - C4	Wiring diagram 1 - M4	FR-E500.Lst
	FR-S500	RS-485 connector				
FR-V500	FR-V500	PU connector				FR-V500.Lst
FR-E700	FR-E700	PU connector	FR-E700.Lst			

Servo

PLC Selection on the Editor	Model	Port	Signal level	Connection		Lst File
				CN1	MJ1/MJ2	
MR-J2S-*A	MR-J2S-*A	CN3	RS-232C	Wiring diagram 1 - C2	Wiring diagram 1 - M2	M_J2S_A.Lst
			RS-485	Wiring diagram 2 - C4	×	
MR-J3-*A	MR-J3-*A	CN3	RS-485	Wiring diagram 1 - C4	×	MRJ3.Lst
MR-J3-*T	MR-J3-*T	CN3				MRJ3_T.Lst

9.2.1 FR-*500

Communication Setting

Editor

Communication setting

(Underlined setting: default)

Item	Setting	Remarks
Connection Mode	1 : 1 / <u>1 : n</u> / Multi-link / Multi-link2 / Multi-link2 (Ethernet) / 1 : n Multi-link2 (Ethernet)	
Signal Level	RS-232C / <u>RS-422/485</u>	
Baud Rate	4800 / 9600 / <u>19200</u> bps	
Data Length	7 / <u>8</u> bits	
Stop Bit	1 / <u>2</u> bits	
Parity	None / Odd / <u>Even</u>	
Target Port No.	<u>0</u> to 31	
CR/LF	None / <u>CR</u> / CRLF	

Inverter

(Underlined setting: default)

Parameter No.		Item	Setting	Setting Example
A500 E500 F500	S500 F500J			
77	77	Parameter writing permission	<u>0: Writing allowed when PU operation stops</u> 1: Writing prohibited 2: Writing allowed during operation	2: Writing allowed during operation
79	79	Operation mode selection *2	0 / <u>1</u> / 2 / 3 / 4 / 6 / 7 / 8	1: PU operation *3 2: External operation *3
117	n1	Communicating station number	<u>0</u> to 31	0
118	n2	Baud rate	4800 / 9600 / <u>19200</u> bps	19200 bps
119	n3	Data length / stop bit length	0: 8 bits / 1 bit <u>1: 8 bits / 2 bits</u> 10: 7 bits / 1 bit 11: 7 bits / 2 bits	1: 8 bits / 2 bits
120	n4	Parity check	0: None 1: Odd <u>2: Even</u>	2: Even
121	n5	Communication retrial times	<u>0</u> to 10 / 9999	9999: The inverter does not stop even if a communication alarm occurs.
122	n6	Communication check intervals *1	<u>0</u> / 0.1 to 999.8 / 9999	9999: Communication check stop
123	n7	Wait time	0 to 150 / <u>9999</u>	9999: Can be set with the communication data
-	n8	Operation command write	<u>0: Computer</u> 1: External	0: Computer
-	n9	Speed command write	<u>0: Computer</u> 1: External	0: Computer
-	n10	Link start mode selection *2	<u>0</u> 1: Computer link operation mode	1: Computer link operation mode
124	n11	CR/LF selection	0: CR/LF not provided <u>1: CR provided, LF not provided</u> 2: CR/LF provided	1: CR provided, LF not provided
146	-	Frequency setting *2	<u>0</u> / 1 / 9999	9999

*1 When the value in the range from 0.1 to 999.8 is set:

If the V series does not start communication within the preset time, the inverter stops due to an alarm. This can be avoided by the periodical reading setting.

*2 When the inverter, FR-A500, FR-E500 or FR-F500, is turned on with the settings of Pr.79 = 0 and Pr.146 = 9999, the inverter enters in the PU operation mode.
When the inverter, FR-S500 or FR-F500J, is turned on with the settings of Pr.79 = 2 and n10 = 1, the inverter enters in the computer link operation mode.

*3 In the case of FR-A500, FR-E500 or FR-F500, when the running frequency change and operation command specification are made on the V series, select the PU operation mode. In the case of FR-S500 or FR-F500J, when the running frequency change and operation command specification are made on the V series, select the computer link operation mode. If those settings are not made on the V series, set an appropriate value according to the purpose of usage.

Available Device Memory

The available setting range of device memory varies depending on the model. Be sure to set within the range available for the model to be used. Use [TYPE] when assigning indirect device memory for macro programs.

Device Memory	TYPE	Remarks
P (parameter)	00H	Refer to the list file or the parameter list for the inverter.
D (parameter)	01H	Refer to the table below.

D (Parameter)

Address	Name																																																								
D0	Operation mode When issuing a command, such as a run command, from the V series, select "Communication and Run". FR-E500 : 0002 H FR-A500 : 0002 H FR-F500 : 0002 H FR-S500 : 0000 H																																																								
D1	Output frequency (Rotation)																																																								
D2	Output current																																																								
D3	Output voltage																																																								
D4	Alarm contents (last / most recent) <table border="1"> <thead> <tr> <th>Data</th> <th>Contents</th> <th>Data</th> <th>Contents</th> <th>Data</th> <th>Contents</th> <th>Data</th> <th>Contents</th> </tr> </thead> <tbody> <tr> <td>H00</td> <td>none</td> <td>H22</td> <td>OV3</td> <td>H80</td> <td>GF</td> <td>HB2</td> <td>RET</td> </tr> <tr> <td>H10</td> <td>OC1</td> <td>H30</td> <td>THT</td> <td>H81</td> <td>LF</td> <td>HC2</td> <td>P24</td> </tr> <tr> <td>H11</td> <td>OC2</td> <td>H31</td> <td>THM</td> <td>H90</td> <td>OHT</td> <td>HF3</td> <td>E.3</td> </tr> <tr> <td>H12</td> <td>OC3</td> <td>H40</td> <td>FIN</td> <td>HA0</td> <td>OPT</td> <td>HF6</td> <td>E.6</td> </tr> <tr> <td>H20</td> <td>OV1</td> <td>H60</td> <td>OLT</td> <td>HB0</td> <td>PE</td> <td>HF7</td> <td>E.7</td> </tr> <tr> <td>H21</td> <td>OV2</td> <td>H70</td> <td>BE</td> <td>HB1</td> <td>PUE</td> <td></td> <td></td> </tr> </tbody> </table>	Data	Contents	Data	Contents	Data	Contents	Data	Contents	H00	none	H22	OV3	H80	GF	HB2	RET	H10	OC1	H30	THT	H81	LF	HC2	P24	H11	OC2	H31	THM	H90	OHT	HF3	E.3	H12	OC3	H40	FIN	HA0	OPT	HF6	E.6	H20	OV1	H60	OLT	HB0	PE	HF7	E.7	H21	OV2	H70	BE	HB1	PUE		
Data	Contents	Data	Contents	Data	Contents	Data	Contents																																																		
H00	none	H22	OV3	H80	GF	HB2	RET																																																		
H10	OC1	H30	THT	H81	LF	HC2	P24																																																		
H11	OC2	H31	THM	H90	OHT	HF3	E.3																																																		
H12	OC3	H40	FIN	HA0	OPT	HF6	E.6																																																		
H20	OV1	H60	OLT	HB0	PE	HF7	E.7																																																		
H21	OV2	H70	BE	HB1	PUE																																																				
D5	Alarm contents (three times before / two times before)																																																								
D6	Alarm contents (five times before / four times before) *																																																								
D7	Alarm contents (seven times before / six times before) *																																																								
D8	Inverter status monitor 																																																								
D9	Changeover to second parameter																																																								

* These memory addresses are not available for FR-S500



When setting device memory:

By default, only the "List" file of "FR-E500" can be browsed by pressing the [Refer] button. If an inverter such as "A500", "F500", or "S500" is used, refer to the parameter list described in each inverter's manual and then set the device memory.

PLC_CTL

Macro command "PLC_CTL F0 F1 F2"

Contents	F0	F1 (= \$u n)					F2	
Writing running frequency (EEPROM)	1 - 8 (PLC1 - 8)	n	Station number				3	
		n + 1	Command: 00EEH					
		n + 2	Running frequency					
Writing running frequency (RAM)	1 - 8 (PLC1 - 8)	n	Station number				3	
		n + 1	Command: 00EDH					
		n + 2	Running frequency					
All alarms clear	1 - 8 (PLC1 - 8)	n	Station number				2	
		n + 1	Command: 00F4H					
Operation command	1 - 8 (PLC1 - 8)	n	Station number				3	
		n + 1	Command: 00FAH					
		n + 2	0000H: Stop 0002H: Normal rotation (STF) 0004H: Reverse rotation (STR)					
All parameter clear	1 - 8 (PLC1 - 8)	n	Station number				3	
		n + 1	Command: 00FCH					
		n + 2	Pr.	Communication Pr.	Calibration	Other Pr.		00ECH 00F3H 00FFH
			Data					
			9696H	○	×	○		○
			9966H	○	○	○		○
5A5AH	×	×	○	○				
55AAH	×	○	○	○				
Inverter reset	1 - 8 (PLC1 - 8)	n	Station number				2	
		n+1	Command: 00FDH					

9.2.2 FR-V500

Communication Setting

Editor

Communication setting

(Underlined setting: default)

Item	Setting	Remarks
Connection Mode	1 : 1 / <u>1 : n</u> / Multi-link2 / Multi-link2 (Ethernet) / 1 : n Multi-link2 (Ethernet)	
Signal Level	RS-232C / <u>RS-422/485</u>	
Baud Rate	4800 / 9600 / <u>19200</u> bps	
Data Length	7 / <u>8</u> bits	
Stop Bit	1 / <u>2</u> bits	
Parity	None / Odd / <u>Even</u>	
Target Port No.	<u>0</u> to 31	
CR/LF	None / <u>CR</u> / CRLF	

Inverter

(Underlined setting: default)

Parameter No.	Item	Setting	Setting Example
77	Parameter writing permission	<u>0: Writing allowed when PU operation stops</u> 1: Writing prohibited 2: Writing allowed during operation	2: Writing allowed during operation
79	Operation mode selection *2	<u>0</u> / 1 / 2 / 3 / 4 / 6 / 7 / 8	1: PU operation
117	Communicating station number	<u>0</u> to 31	0
118	Baud rate	4800 / 9600 / <u>19200</u> bps	19200 bps
119	Data length / stop bit length	0: 8 bits / 1 bit <u>1: 8 bits / 2 bits</u> 10: 7 bits / 1 bit 11: 7 bits / 2 bits	1: 8 bits / 2 bits
120	Parity check	0: None 1: Odd 2: Even	2: Even
121	Communication retrial times	0 to 10 / 9999	9999: The inverter does not stop even if a communication alarm occurs.
122	Communication check intervals *1	<u>0</u> / 0.1 to 999.8 / 9999	9999: Communication check stop
123	Wait time	0 to 150 / <u>9999</u>	9999: Can be set with the communication data
124	CR/LF selection	0: CR/LF not provided <u>1: CR provided, LF not provided</u> 2: CR/LF provided	1: CR provided, LF not provided
146	Frequency setting *2	<u>0</u> / 1 / 9999	9999

*1 When the value in the range from 0.1 to 999.8 is set:
If the V series does not start communication within the preset time, the inverter stops due to an alarm. This can be avoided by the periodical reading setting.

*2 When the inverter is turned on with the settings of Pr.79=0 and Pr.146=9999, the inverter enters in the PU operation mode.

Available Device Memory

The available setting range of device memory varies depending on the model. Be sure to set within the range available for the model to be used. Use [TYPE] when assigning indirect device memory for macro programs.

Device Memory	TYPE	Remarks
P (parameter)	00H	Refer to the list file or the parameter list for the inverter.
D (parameter)	01H	Refer to the table below.

D (Parameter)

Address	Name																																																																														
D0	Operation mode When issuing a command, such as a run command, from the V series, select "Communication and Run". 0002 H																																																																														
D1	Rotation speed																																																																														
D2	Output current																																																																														
D3	Output voltage																																																																														
D4	Alarm contents (last / most recent)																																																																														
D5	Alarm contents (three times before / two times before)																																																																														
D6	Alarm contents (five times before / four times before)																																																																														
D7	Alarm contents (seven times before / six times before)																																																																														
D8	Inverter status monitor 																																																																														
D9	Changeover to second parameter																																																																														
D10	Special monitor																																																																														
D11	Special monitor selection No. <table border="1"> <thead> <tr> <th>Data</th> <th>Contents</th> <th>Unit</th> <th>Data</th> <th>Contents</th> <th>Unit</th> </tr> </thead> <tbody> <tr> <td>H01</td> <td>Output frequency</td> <td>0.01 Hz</td> <td>H10</td> <td>Output terminal status</td> <td>-</td> </tr> <tr> <td>H02</td> <td>Output current</td> <td>0.01 A</td> <td>H11</td> <td>Load meter</td> <td>0.1%</td> </tr> <tr> <td>H03</td> <td>Output voltage</td> <td>0.1V</td> <td>H12</td> <td>Motor exciting current</td> <td>0.01A</td> </tr> <tr> <td>H05</td> <td>Speed setting</td> <td>1 r/min</td> <td>H13</td> <td>Position pulse</td> <td>-</td> </tr> <tr> <td>H06</td> <td>Operation speed</td> <td>1 r/min</td> <td>H14</td> <td>Total power-on time</td> <td>1h</td> </tr> <tr> <td>H07</td> <td>Motor torque</td> <td>0.1%</td> <td>H17</td> <td>Operating time</td> <td>1h</td> </tr> <tr> <td>H08</td> <td>Converter output</td> <td>0.1 V</td> <td>H18</td> <td>Motor load ratio</td> <td>0.1%</td> </tr> <tr> <td>H09</td> <td>Regenerative brake</td> <td>0.1%</td> <td>H20</td> <td>Torque command</td> <td>0.1%</td> </tr> <tr> <td>H0A</td> <td>Electric thermal load ratio</td> <td>0.1%</td> <td>H21</td> <td>Torque current command</td> <td>0.1%</td> </tr> <tr> <td>H0B</td> <td>Output current peak value</td> <td>0.01 A</td> <td>H22</td> <td>Motor output</td> <td>0.01 kW</td> </tr> <tr> <td>H0C</td> <td>Output voltage peak value of converter</td> <td>0.1 V</td> <td>H23</td> <td>Feed back pulse</td> <td>-</td> </tr> <tr> <td>H0F</td> <td>Input terminal status</td> <td>-</td> <td></td> <td></td> <td></td> </tr> </tbody> </table> Input terminal status Bit 15 - 8 RES CH D14 D13 D12 D11 STR STF Output terminal status Bit 15 - - - - 4 ABC D03 D02 D01	Data	Contents	Unit	Data	Contents	Unit	H01	Output frequency	0.01 Hz	H10	Output terminal status	-	H02	Output current	0.01 A	H11	Load meter	0.1%	H03	Output voltage	0.1V	H12	Motor exciting current	0.01A	H05	Speed setting	1 r/min	H13	Position pulse	-	H06	Operation speed	1 r/min	H14	Total power-on time	1h	H07	Motor torque	0.1%	H17	Operating time	1h	H08	Converter output	0.1 V	H18	Motor load ratio	0.1%	H09	Regenerative brake	0.1%	H20	Torque command	0.1%	H0A	Electric thermal load ratio	0.1%	H21	Torque current command	0.1%	H0B	Output current peak value	0.01 A	H22	Motor output	0.01 kW	H0C	Output voltage peak value of converter	0.1 V	H23	Feed back pulse	-	H0F	Input terminal status	-			
Data	Contents	Unit	Data	Contents	Unit																																																																										
H01	Output frequency	0.01 Hz	H10	Output terminal status	-																																																																										
H02	Output current	0.01 A	H11	Load meter	0.1%																																																																										
H03	Output voltage	0.1V	H12	Motor exciting current	0.01A																																																																										
H05	Speed setting	1 r/min	H13	Position pulse	-																																																																										
H06	Operation speed	1 r/min	H14	Total power-on time	1h																																																																										
H07	Motor torque	0.1%	H17	Operating time	1h																																																																										
H08	Converter output	0.1 V	H18	Motor load ratio	0.1%																																																																										
H09	Regenerative brake	0.1%	H20	Torque command	0.1%																																																																										
H0A	Electric thermal load ratio	0.1%	H21	Torque current command	0.1%																																																																										
H0B	Output current peak value	0.01 A	H22	Motor output	0.01 kW																																																																										
H0C	Output voltage peak value of converter	0.1 V	H23	Feed back pulse	-																																																																										
H0F	Input terminal status	-																																																																													

PLC_CTL

Macro command "PLC_CTL F0 F1 F2"

Contents	F0	F1 (= \$u n)					F2	
Writing setting speed (EEPROM)	1 - 8 (PLC1 - 8)	n	Station number				3	
		n + 1	Command: 00EEH					
		n + 2	Running frequency					
Writing setting speed (RAM)	1 - 8 (PLC1 - 8)	n	Station number				3	
		n + 1	Command: 00EDH					
		n + 2	Running frequency					
All alarms clear	1 - 8 (PLC1 - 8)	n	Station number				2	
		n + 1	Command: 00F4H					
Operation command	1 - 8 (PLC1 - 8)	n	Station number				3	
		n + 1	Command: 00FAH					
		n + 2	0000H: Stop 0002H: Normal rotation (STF) 0004H: Reverse rotation (STR)					
All parameter clear	1 - 8 (PLC1 - 8)	n	Station number				3	
		n + 1	Command: 00FCH					
		n + 2	Pr.	Communication Pr.	Calibration	Other Pr.		00ECH 00F3H 00FFH
			Data					
			9696H	○	×	○		○
			9966H	○	○	○		○
5A5AH	×	×	○	○				
55AAH	×	○	○	○				
Inverter reset	1 - 8 (PLC1 - 8)	n	Station number				2	
		n+1	Command: 00FDH					

9.2.3 MR-J2S-*A

Communication Setting

Editor

Communication setting

(Underlined setting: default)

Item	Setting	Remarks
Connection Mode	1 : 1 / <u>1</u> : n / Multi-link2 / Multi-link2 (Ethernet) / 1 : n Multi-link2 (Ethernet)	
Signal Level	<u>RS-232C</u> / RS-422/485	
Baud Rate	<u>9600</u> / 19200 / 38400 / 57600 bps	
Data Length	8 bits (fixed)	
Stop Bit	1 bit (fixed)	
Parity	Even (fixed)	
Target Port No.	<u>0</u> to 31	

Servo amplifier

Extension setting parameters

To make the parameter setting valid, the power supply is turned on again.

(Underlined setting: default)

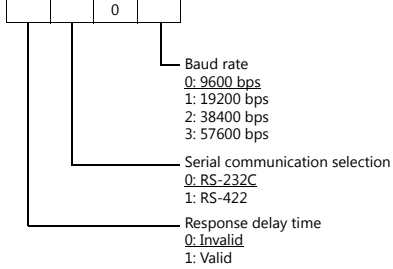
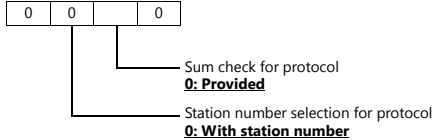
Parameter No.	Symbol	Item	Setting Example
15	SNO	Station number setting	<u>0</u> to 31
16	BPS	Communication function selection	 <p>Baud rate 0: 9600 bps 1: 19200 bps 2: 38400 bps 3: 57600 bps</p> <p>Serial communication selection 0: <u>RS-232C</u> 1: RS-422</p> <p>Response delay time 0: <u>Invalid</u> 1: Valid</p>
53	OP8	Function selection 8	 <p>Sum check for protocol 0: Provided</p> <p>Station number selection for protocol 0: With station number</p>

Available Device Memory

The available setting range of device memory varies depending on the model. Be sure to set within the range available for the model to be used. Use [TYPE] when assigning indirect device memory for macro programs.

Device Memory	TYPE	Remarks
F01 (status display/fraction display)	00H	Real number, read only
05 (parameter)	01H	Double-word
F05 (parameter/fraction display)	02H	Real number
12 (External I/O signals)	03H	Double-word, partially read only
33 (Alarm history)	04H	Double-word, read only
02 (Current alarm)	05H	Read only
F35 (Status display at alarm occurrence/fraction display)	06H	Real number, read only
42 (Other commands)	0DH	Double-word, read only
81 (Status display data erasure)	0EH	Write only
82 (Alarm history erasure)	0FH	Write only
8B (Operation mode selection)	10H	Write only
90 (I/O device prohibition/cancel)	11H	Write only
92 (Input device ON/OFF)	12H	Double-word, write only
A0 (Test operation mode data)	13H	Double-word, write only

Set the target device memory on the [Device Input] dialog.

- RAM: Stored in RAM
- EEPROM: Stored in RAM + EEPROM

Indirect Device Memory Designation

- Address No. 0 to 65535

	15	8	7	0
n+0	Models		Device Type	
n+1	Address No.			
n+2	Expansion code *		Bit designation	
n+3	00		Station number	

* Expansion code

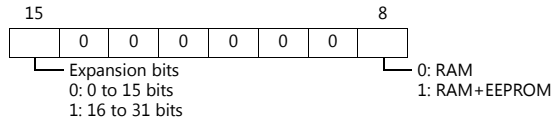

PLC_CTL

Macro command "PLC_CTL F0 F1 F2"

Contents	F0	F1 (= \$u n)	F2	
Software version	1 - 8 (PLC1 - 8)	n	3	
		n + 1		Station number
		n + 2		Command: 0002H
		n + 3 to n+10		Data No. 0070H
		n+3 to n+10	Software version	

Return data: Data stored from controller to V series

9.2.4 MR-J3-*A

Communication Setting

Editor

Communication setting

(Underlined setting: default)

Item	Setting	Remarks
Connection Mode	1 : 1 / <u>1</u> : n / Multi-link2 / Multi-link2 (Ethernet) / 1 : n Multi-link2 (Ethernet)	
Signal Level	RS-232C / <u>RS-422</u> /485	
Baud Rate	<u>9600</u> / 19200 / 38400 / 57600 / 115K bps	
Data Length	8 bits	
Stop Bit	1 bit	
Parity	Even	
Target Port No.	<u>0</u> to 31	

Servo amplifier

Extension setting parameters

To make the parameter setting valid, the power supply is turned on again.

(Underlined setting: default)

Parameter No.	Symbol	Item	Setting Example
PC20	SNO	Station number setting	<u>0</u> to 31
PC21	SOP	Communication function selection	

Available Device Memory

The available setting range of device memory varies depending on the model. Be sure to set within the range available for the model to be used. Use [TYPE] when assigning indirect device memory for macro programs.

Device Memory	TYPE	Remarks
F01 (status display)	00H	Real number, read only
12 (external I/O signals)	03H	Double-word, partially read only
33 (alarm history)	04H	Double-word, read only
02 (current alarm)	05H	Read only
F35 (status display at alarm occurrence)	06H	Real number, read only
42 (other commands)	0DH	Double-word, read only
81 (status display data erasure)	0EH	Write only
82 (alarm history erasure)	0FH	Write only
8B (operation mode selection)	10H	
90 (I/O device prohibition/cancel)	11H	Write only
92 (input device ON/OFF)	12H	Double-word, write only
A0 (test operation mode data)	13H	Double-word, write only
S01 (status display name and unit)	14H	Read only
04 (parameters)	15H	
05A (basic setting parameters)	16H	Double-word
05B (gain/filter parameters)	17H	Double-word
05C (extension setting parameters)	18H	Double-word
05D (I/O setting parameters)	19H	Double-word
F05A (basic setting parameters)	1AH	Real number
F05B (gain/filter parameters)	1BH	Real number
F05C (extension setting parameters)	1CH	Real number
F05D (I/O setting parameters)	1DH	Real number

Device Memory	TYPE	Remarks
06A (basic setting parameters upper limit)	1EH	Double-word, read only
06B (gain/filter parameters upper limit)	1FH	Double-word, read only
06C (extension setting parameters upper limit)	20H	Double-word, read only
06D (I/O setting parameters upper limit)	21H	Double-word, read only
F06A (basic setting parameters upper limit)	22H	Real number, read only
F06B (gain/filter parameters upper limit)	23H	Real number, read only
F06C (extension setting parameters upper limit)	24H	Real number, read only
F06D (I/O setting parameters upper limit)	25H	Real number, read only
07A (basic setting parameters lower limit)	1EH	Double-word, read only
07B (gain/filter parameters lower limit)	1FH	Double-word, read only
07C (extension setting parameters lower limit)	20H	Double-word, read only
07D (I/O setting parameters lower limit)	21H	Double-word, read only
F07A (basic setting parameters lower limit)	22H	Real number, read only
F07B (gain/filter parameters lower limit)	23H	Real number, read only
F07C (extension setting parameters lower limit)	24H	Real number, read only
F07D (I/O setting parameters lower limit)	25H	Real number, read only
S08A (basic setting parameters symbol)	2EH	Read only
S08B (gain/filter parameters symbol)	2FH	Read only
S08C (extension setting parameters symbol)	30H	Read only
S08D (I/O setting parameters symbol)	31H	Read only
09A (write enable/disable of basic setting parameters)	32H	Read only
09B (write enable/disable of Gain/filter parameters)	33H	Read only
09C (write enable/disable of Extension setting parameters)	34H	Read only
09D (write enable/disable of I/O setting parameters)	35H	Read only

Set the target device memory on the [Device Input] dialog.

- RAM: Stored in RAM
- EEPROM: Stored in RAM + EEPROM

Indirect Device Memory Designation

- Address No. 0 to 65535

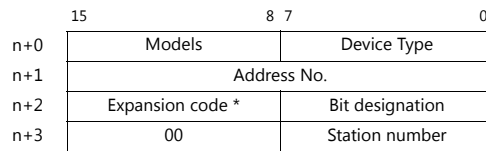

* Expansion code

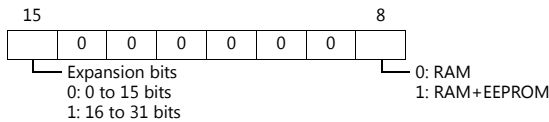

PLC_CTL

Macro command "PLC_CTL F0 F1 F2"

Contents	F0	F1 (= \$u n)		F2
Software version	1 - 8 (PLC1 - 8)	n	Station number	3
		n + 1	Command: 0002H	
		n + 2	Data No. 0070H	
		n+3 to n+10	Software version	

Return data: Data stored from controller to V series

9.2.5 MR-J3-*T

Communication Setting

Editor

Communication setting

(Underlined setting: default)

Item	Setting	Remarks
Connection Mode	1 : 1 / <u>1</u> : n / Multi-link2 / Multi-link2 (Ethernet) / 1 : n Multi-link2 (Ethernet)	
Signal Level	RS-232C / <u>RS-422/485</u>	
Baud Rate	<u>9600</u> / 19200 / 38400 / 57600 / 115K bps	
Data Length	8 bits (fixed)	
Stop Bit	1 bit (fixed)	
Parity	Even (fixed)	
Target Port No.	<u>0</u> to 31	

Servo amplifier

Extension setting parameters

To make the parameter setting valid, the power supply is turned on again.

(Underlined setting: default)

Parameter No.	Symbol	Item	Setting Example
PC20	SNO	Station number setting	<u>0</u> to 31
PC21	SOP	Communication function selection	

Available Device Memory

The available setting range of device memory varies depending on the model. Be sure to set within the range available for the model to be used. Use [TYPE] when assigning indirect device memory for macro programs.

Device Memory	TYPE	Remarks
F01 (status display)	00H	Real number, read only
12 (external I/O signals)	03H	Double-word, partially read only
33 (alarm history)	04H	Double-word, read only
02 (current alarm)	05H	Read only
F35 (status display at alarm occurrence)	06H	Real number, read only
42 (other commands)	0DH	Double-word, read only
81 (status display data erasure)	0EH	Write only
82 (alarm history erasure)	0FH	Write only
8B (operation mode selection)	10H	
90 (I/O device prohibition/cancel)	11H	Write only
92 (input device ON/OFF)	12H	Double-word, write only
A0 (test operation mode data)	13H	Double-word, write only
S01 (status display name and unit)	14H	Read only
04 (parameters)	15H	
05A (basic setting parameters)	16H	Double-word
05B (gain/filter parameters)	17H	Double-word
05C (extension setting parameters)	18H	Double-word
05D (I/O setting parameters)	19H	Double-word
F05A (basic setting parameters)	1AH	Real number
F05B (gain/filter parameters)	1BH	Real number
F05C (extension setting parameters)	1CH	Real number
F05D (I/O setting parameters)	1DH	Real number

Device Memory	TYPE	Remarks
06A (basic setting parameters upper limit)	1EH	Double-word, read only
06B (gain/filter parameters upper limit)	1FH	Double-word, read only
06C (extension setting parameters upper limit)	20H	Double-word, read only
06D (I/O setting parameters upper limit)	21H	Double-word, read only
F06A (basic setting parameters upper limit)	22H	Real number, read only
F06B (gain/filter parameters upper limit)	23H	Real number, read only
F06C (extension setting parameters upper limit)	24H	Real number, read only
F06D (I/O setting parameters upper limit)	25H	Real number, read only
07A (basic setting parameters lower limit)	1EH	Double-word, read only
07B (gain/filter parameters lower limit)	1FH	Double-word, read only
07C (extension setting parameters lower limit)	20H	Double-word, read only
07D (I/O setting parameters lower limit)	21H	Double-word, read only
F07A (basic setting parameters lower limit)	22H	Real number, read only
F07B (gain/filter parameters lower limit)	23H	Real number, read only
F07C (extension setting parameters lower limit)	24H	Real number, read only
F07D (I/O setting parameters lower limit)	25H	Real number, read only
S08A (basic setting parameters symbol)	2EH	Read only
S08B (gain/filter parameters symbol)	2FH	Read only
S08C (extension setting parameters symbol)	30H	Read only
S08D (I/O setting parameters symbol)	31H	Read only
09A (write enable/disable of basic setting parameters)	32H	Read only
09B (write enable/disable of gain/filter parameters)	33H	Read only
09C (write enable/disable of extension setting parameters)	34H	Read only
09D (write enable/disable of I/O setting parameters)	35H	Read only
F40 (point table Point data)	36H	Real number
50 (point table Servo motor speed)	37H	Double-word
54 (point table Acceleration time constant)	38H	Double-word
58 (point table Deceleration time constant)	39H	Double-word
60 (point table Dwell)	3AH	Double-word
64 (point table Auxiliary function)	3BH	Double-word
45 (point table M code)	3CH	Double-word

Set the target device memory on the [Device Input] dialog.

- RAM: Stored in RAM
- EEPROM: Stored in RAM + EEPROM

Indirect Device Memory Designation

- Address No. 0 to 65535

	15	8 7	0
n+0	Models	Device Type	
n+1	Address No.		
n+2	Expansion code *	Bit designation	
n+3	00	Station number	

* Expansion code

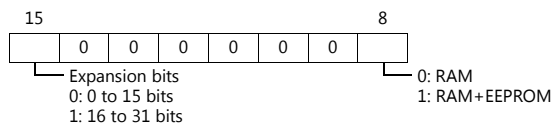

PLC_CTL

Macro command "PLC_CTL F0 F1 F2"

Contents	F0	F1 (= \$u n)		F2
Software version	1 - 8 (PLC1 - 8)	n	Station number	3
		n + 1	Command: 0002H	
		n + 2	Data No. 0070H	
		n+3 to n+10	Software version	
Option unit parameter Read	1 - 8 (PLC1 - 8)	n	Station number	4
		n + 1	Command: 0005H	
		n + 2	Data Type 0: Normal 1: Real number (decimal)	
		n + 3	Parameter No. *1	
		n + 4	Parameter (low-order)	
Option unit parameter Write	1 - 8 (PLC1 - 8)	n	Station number	7
		n + 1	Command: 0084H	
		n + 2	Data Type 0: Normal 1: Real number (decimal)	
		n + 3	Parameter No. *1	
		n + 4	Parameter (low-order)	
		n + 5	Parameter (low-order)	
Option unit parameter upper limit values read	1 - 8 (PLC1 - 8)	n	Station number	4
		n + 1	Command: 0006H	
		n + 2	Data Type 0: Normal 1: Real number (decimal)	
		n + 3	Parameter No. *1	
		n + 4	Parameter (low-order)	
Option unit parameter lower limit values read	1 - 8 (PLC1 - 8)	n	Station number	4
		n + 1	Command: 0007H	
		n + 2	Data Type 0: Normal 1: Real number (decimal)	
		n + 3	Parameter No. *1	
		n + 4	Parameter (low-order)	
Option unit parameter Abbreviations read	1 - 8 (PLC1 - 8)	n	Station number	3
		n + 1	Command: 0008H	
		n + 2	Parameter No. *1	
		n+3 to n+7	Abbreviations	
Option unit parameter Write enable/disable read	1 - 8 (PLC1 - 8)	n	Station number	3
		n + 1	Command: 0009H	
		n + 2	Parameter No. *1	
		n+3	0: Write enabled 1: Write disabled	

*1 Option unit parameter

Return data: Data stored from controller to V series

No.	Contents
2	MR-J3-D01 Input signal device selection 1 (CN10-21, 26)
3	MR-J3-D01 Input signal device selection 2 (CN10-27, 28)
4	MR-J3-D01 Input signal device selection 3 (CN10-29, 30)
5	MR-J3-D01 Input signal device selection 4 (CN10-31, 32)
6	MR-J3-D01 Input signal device selection 5 (CN10-33, 34)
7	MR-J3-D01 Input signal device selection 6 (CN10-35, 36)
8	MR-J3-D01 Output signal device selection 1 (CN10-46, 47)
9	MR-J3-D01 Output signal device selection 2 (CN10-48, 49)

No.	Contents
10	Function selection O-1
12	Function selection O-3
13	MR-J3-D01 Analog monitor 1 output
14	MR-J3-D01 Analog monitor 2 output
15	MR-J3-D01 Analog monitor 1 offset
16	MR-J3-D01 Analog monitor 2 offset
21	MR-J3-D01 Override offset
22	MR-J3-D01 Analog torque limit offset

9.2.6 FR-E700

Communication Setting

Editor

Communication setting

(Underlined setting: default)

Item	Setting	Remarks
Connection Mode	1 : 1 / <u>1 : n</u> / Multi-link2 / Multi-link2 (Ethernet) / 1 : n Multi-link2 (Ethernet)	
Signal Level	RS-232C / <u>RS-422/485</u>	
Baud Rate	4800 / 9600 / <u>19200</u> bps	
Data Length	7 / <u>8</u> bits	
Stop Bit	1 / <u>2</u> bits	
Parity	None / Odd / <u>Even</u>	
Target Port No.	<u>0</u> to 31	
CR/LF	None / <u>CR</u> / CRLF	

Inverter

When setting run commands and set frequency commands from V9, select the Network operation mode. For more information, refer to the Instruction Manual (Applied) of inverter.

Be sure to reset the inverter after making the initial settings of the parameters. Otherwise, communication is not possible.

(Underlined setting: default)

Parameter No.	Item	Setting	Setting Example
77	Parameter writing permission	<u>0: Writing allowed when PU operation stops</u> 1: Writing prohibited 2: Writing allowed during operation	2
79	Operation mode selection *3	<u>0</u> / 1 / 2 / 3 / 4 / 6 / 7	2 : External operation mode
117	PU communication station number	<u>0</u> to 31	0
118	PU communication speed	4800 / 9600 / <u>19200</u> / 38400bps	19200 bps
119	PU communication stop bit length (data length)	0: 8 bits / 1 bit <u>1: 8 bits / 2 bits</u> 10: 7 bits / 1 bit 11: 7 bits / 2 bits	1
120	PU communication parity check	0: None 1: Odd <u>2: Even</u>	2
121	Number of PU communication retries	0 to 10 / 9999	9999: The inverter does not stop even if a communication alarm occurs.
122	PU communication check time interval	<u>0</u> *1 0.1 to 999.8 *2 9999	9999: No communication check
123	PU communication waiting time setting	0 to 150 / <u>9999</u>	9999: Can be set with the communication data
124	PU communication CR/LF selection	0: Without CR/LF <u>1: With CR</u> 2: With CR/LF	1
338	Communication operation command source	<u>0: communication</u> 1: external	0
339	Communication speed command source	<u>0: communication</u> 1: external (communication invalid) 2: external (communication valid)	0
340	Communication startup mode selection *3	<u>0: As set in Pr.79</u> 1: Network operation mode 10: Network operation mode *4	1
549	Protocol selection	<u>0: Mitsubishi inverter protocol</u> 1: Modbus-RTU protocol	0
550	NET mode operation command source selection	0: communication option 2: PU connector <u>9999: Automatic communication option recognition</u>	9999 When using a communication option set 2.
551	PU mode operation command source selection	2: PU connector 3: USB connector 4: Operation panel <u>9999: USB automatic recognition</u>	9999

- *1 RS-485 communication is possible. Note that a communication fault (E.PUE) occurs as soon as the inverter is switched to the operation mode with command source.
- *2 When the value in the range from 0.1 to 999.8 is set:
If the V series does not start communication within the preset time, the inverter stops due to an alarm. This can be avoided by the periodical reading setting.
- *3 When the inverter is turned on with the settings of Pr.79=0/2/6 and Pr.340=1, the inverter enters in the Network operation mode.
- *4 Operation mode can be changed between the PU operation mode and Network operation mode from the operation panel.

Available Device Memory

The available setting range of device memory varies depending on the model. Be sure to set within the range available for the model to be used. Use [TYPE] when assigning indirect device memory for macro programs.

Device Memory	TYPE	Remarks
P (parameter)	00H	Refer to the list file or the parameter list for the inverter.
D (parameter)	01H	Refer to the table below.

D (Parameter)

Address	Name																																																																																																													
D0	Operation mode 0000 H: Network operation 0001 H: External operation 0002 H: PU operation																																																																																																													
D1	Pr.37=0 : Frequency display, setting Pr.37≠0 : Machine speed at 60 Hz																																																																																																													
D2	Output current																																																																																																													
D3	Output voltage																																																																																																													
D4	Fault description (First fault in past / Latest fault)																																																																																																													
D5	Fault description (Third fault in past / Second fault in past)																																																																																																													
D6	Fault description (Fifth fault in past / Fourth fault in past)																																																																																																													
D7	Fault description (Seventh fault in past / Sixth fault in past)																																																																																																													
D8	<p>Inverter status monitor</p> <p>* Definitions change according to the Pr.190 to 192.</p>																																																																																																													
D9	Second parameter changing																																																																																																													
D10	Special monitor																																																																																																													
D11	<p>Special monitor selection No.</p> <table border="1" style="display: inline-table; margin-right: 20px;"> <thead> <tr> <th>Data</th> <th>Contents</th> <th>Unit</th> </tr> </thead> <tbody> <tr><td>H01</td><td>Output frequency / speed</td><td>0.01 Hz / 0.001</td></tr> <tr><td>H02</td><td>Output current</td><td>0.01 A</td></tr> <tr><td>H03</td><td>Output voltage</td><td>0.1V</td></tr> <tr><td>H05</td><td>Frequency setting / speed setting</td><td>0.01 HZ / 0.001</td></tr> <tr><td>H07</td><td>Motor torque</td><td>0.1 %</td></tr> <tr><td>H08</td><td>Converter output voltage</td><td>0.1 V</td></tr> <tr><td>H09</td><td>Regenerative brake duty</td><td>0.1 %</td></tr> <tr><td>H0A</td><td>Electric thermal relay function load factor</td><td>0.1 %</td></tr> <tr><td>H0B</td><td>Output current peak value</td><td>0.01 A</td></tr> <tr><td>H0C</td><td>Converter output voltage peak value</td><td>0.1 V</td></tr> <tr><td>H0E</td><td>Output power</td><td>0.01 kW</td></tr> <tr><td>H0F</td><td>Input terminal status^{*1}</td><td>-</td></tr> </tbody> </table> <table border="1" style="display: inline-table;"> <thead> <tr> <th>Data</th> <th>Contents</th> <th>Unit</th> </tr> </thead> <tbody> <tr><td>H10</td><td>Output terminal status^{*2}</td><td>-</td></tr> <tr><td>H14</td><td>Cumulative energization time</td><td>1 h</td></tr> <tr><td>H17</td><td>Actual operating time</td><td>1 h</td></tr> <tr><td>H18</td><td>Motor load factor</td><td>0.1%</td></tr> <tr><td>H19</td><td>Cumulative power</td><td>1 kWh</td></tr> <tr><td>H34</td><td>PID set point</td><td>0.1 %</td></tr> <tr><td>H35</td><td>PID measured value</td><td>0.1 %</td></tr> <tr><td>H36</td><td>PID deviation</td><td>0.1 %</td></tr> <tr><td>H3A</td><td>Option input terminal status1^{*3}</td><td>-</td></tr> <tr><td>H3B</td><td>Option input terminal status2^{*3}</td><td>-</td></tr> <tr><td>H3C</td><td>Option output terminal status^{*3}</td><td>-</td></tr> </tbody> </table> <p>*1 Input terminal status</p> <table border="1" style="width: 100%; text-align: center;"> <tr> <td>-</td><td>-</td><td>-</td><td>-</td><td>-</td><td>-</td><td>RES</td><td>-</td><td>MRS</td><td>-</td><td>RH</td><td>RM</td><td>RL</td><td>-</td><td>-</td><td>STR</td><td>STF</td> </tr> </table> <p>*2 Output terminal status</p> <table border="1" style="width: 100%; text-align: center;"> <tr> <td>-</td><td>-</td><td>-</td><td>-</td><td>-</td><td>-</td><td>-</td><td>-</td><td>-</td><td>-</td><td>-</td><td>ABC</td><td>FU</td><td>-</td><td>-</td><td>-</td><td>RUN</td> </tr> </table> <p>*3 Refer to the manual of the inverter.</p>	Data	Contents	Unit	H01	Output frequency / speed	0.01 Hz / 0.001	H02	Output current	0.01 A	H03	Output voltage	0.1V	H05	Frequency setting / speed setting	0.01 HZ / 0.001	H07	Motor torque	0.1 %	H08	Converter output voltage	0.1 V	H09	Regenerative brake duty	0.1 %	H0A	Electric thermal relay function load factor	0.1 %	H0B	Output current peak value	0.01 A	H0C	Converter output voltage peak value	0.1 V	H0E	Output power	0.01 kW	H0F	Input terminal status ^{*1}	-	Data	Contents	Unit	H10	Output terminal status ^{*2}	-	H14	Cumulative energization time	1 h	H17	Actual operating time	1 h	H18	Motor load factor	0.1%	H19	Cumulative power	1 kWh	H34	PID set point	0.1 %	H35	PID measured value	0.1 %	H36	PID deviation	0.1 %	H3A	Option input terminal status1 ^{*3}	-	H3B	Option input terminal status2 ^{*3}	-	H3C	Option output terminal status ^{*3}	-	-	-	-	-	-	-	RES	-	MRS	-	RH	RM	RL	-	-	STR	STF	-	-	-	-	-	-	-	-	-	-	-	ABC	FU	-	-	-	RUN
Data	Contents	Unit																																																																																																												
H01	Output frequency / speed	0.01 Hz / 0.001																																																																																																												
H02	Output current	0.01 A																																																																																																												
H03	Output voltage	0.1V																																																																																																												
H05	Frequency setting / speed setting	0.01 HZ / 0.001																																																																																																												
H07	Motor torque	0.1 %																																																																																																												
H08	Converter output voltage	0.1 V																																																																																																												
H09	Regenerative brake duty	0.1 %																																																																																																												
H0A	Electric thermal relay function load factor	0.1 %																																																																																																												
H0B	Output current peak value	0.01 A																																																																																																												
H0C	Converter output voltage peak value	0.1 V																																																																																																												
H0E	Output power	0.01 kW																																																																																																												
H0F	Input terminal status ^{*1}	-																																																																																																												
Data	Contents	Unit																																																																																																												
H10	Output terminal status ^{*2}	-																																																																																																												
H14	Cumulative energization time	1 h																																																																																																												
H17	Actual operating time	1 h																																																																																																												
H18	Motor load factor	0.1%																																																																																																												
H19	Cumulative power	1 kWh																																																																																																												
H34	PID set point	0.1 %																																																																																																												
H35	PID measured value	0.1 %																																																																																																												
H36	PID deviation	0.1 %																																																																																																												
H3A	Option input terminal status1 ^{*3}	-																																																																																																												
H3B	Option input terminal status2 ^{*3}	-																																																																																																												
H3C	Option output terminal status ^{*3}	-																																																																																																												
-	-	-	-	-	-	RES	-	MRS	-	RH	RM	RL	-	-	STR	STF																																																																																														
-	-	-	-	-	-	-	-	-	-	-	ABC	FU	-	-	-	RUN																																																																																														

Address	Name
D12	<p>Inverter status monitor (expansion)</p> <p>* Definitions change according to the Pr.190 to 192.</p>

PLC_CTL

Macro command "PLC_CTL F0 F1 F2"

Contents	F0	F1 (= \$u n)					F2	
Read set frequency (EEPROM)	1 - 8 (PLC1 - 8)	n	Station number				2	
		n + 1	Command: 006EH					
		n + 2	0 to 65535Hz Pr.37=0 Set frequency in 0.01Hz Pr.37≠0 Speed 0.001					
Read set frequency (RAM)	1 - 8 (PLC1 - 8)	n	Station number				2	
		n + 1	Command: 006DH					
		n + 2	0 to 65535Hz Pr.37=0 Set frequency in 0.01Hz Pr.37≠0 Speed 0.001					
Write set frequency (EEPROM)	1 - 8 (PLC1 - 8)	n	Station number				3	
		n + 1	Command: 00EEH					
		n + 2	0 to 40000Hz Pr.37=0 Set frequency in 0.01Hz Pr.37≠0 Speed 0.001					
Write set frequency (RAM)	1 - 8 (PLC1 - 8)	n	Station number				3	
		n + 1	Command: 00EDH					
		n + 2	0 to 40000Hz Pr.37=0 Set frequency in 0.01Hz Pr.37≠0 Speed 0.001					
Inverter reset	1 - 8 (PLC1 - 8)	n	Station number				3	
		n+1	Command: 00FDH					
		n + 2	9696H: Makes the inverter reset without reply after receiving command. 9966H: Returns ACK and makes the inverter reset after receiving a command.					
All parameter clear	1 - 8 (PLC1 - 8)	n	Station number				3	
		n + 1	Command: 00FCH					
		n + 2	Pr.	Communication Pr.	Calibration Pr.	Other Pr.		00ECH 00F3H 00FFH
			Data					
			9696H *1	○	×	○		○
			9966H *1	○	○	○		○
5A5AH	×		×	○	○			
55AAH	×	○	○	○				

Contents	F0	F1 (= \$u n)		F2
Write run command (Expansion)	1 - 8 (PLC1 - 8)	n	Station number	3
		n+1	Command: 00F9H	
		n + 2	0000H: stop 	
Write run command	1 - 8 (PLC1 - 8)	n	Station number	3
		n + 1	Command: 00FAH	
		n + 2	0000H: stop 	
All alarms clear	1 - 8 (PLC1 - 8)	n	Station number	2
		n + 1	Command: 00F4H	

Return data: Data stored from controller to V series

- *1 When executing this command, the setting values of communication parameter for V9 series are also returned to the initial values. Set the parameter again.
- *2 The description changes depending on the setting of Pr.180 to 184.

9.2.7 Wiring Diagrams

When Connected at CN1:

RS-232C

Wiring diagram 1 - C2

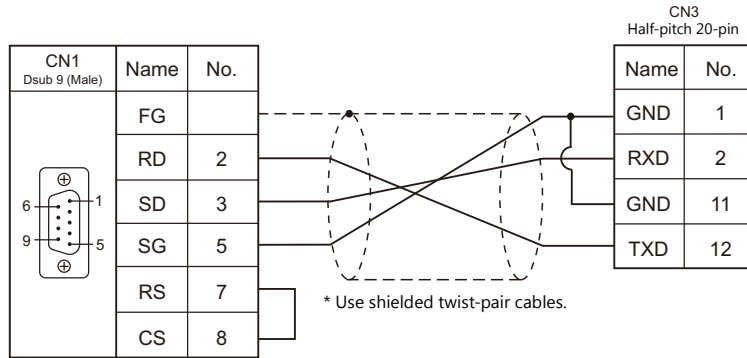

RS-422/RS-485

Wiring diagram 1 - C4

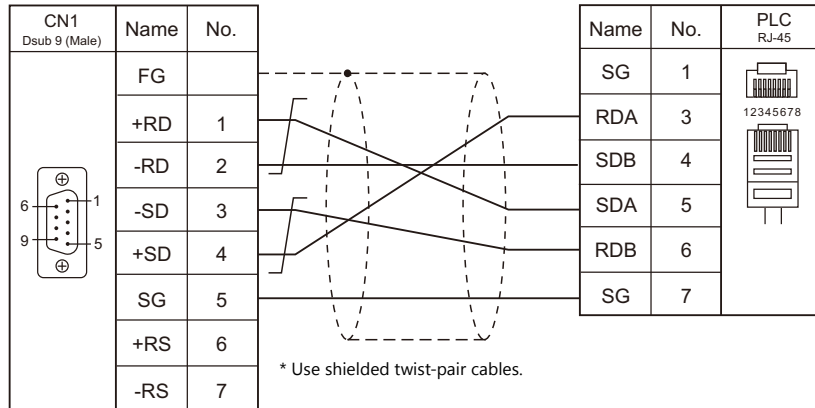

Wiring diagram 2 - C4

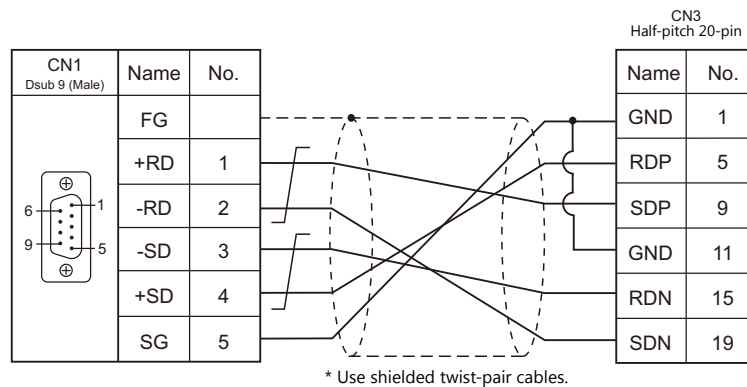

When Connected at MJ1/MJ2:

RS-232C

Wiring diagram 1 - M2

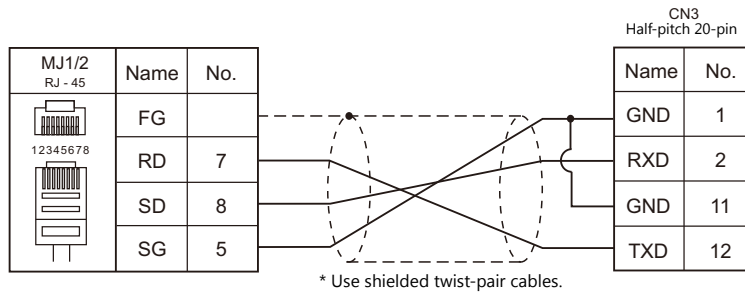

RS-422/RS-485

Wiring diagram 1 - M4

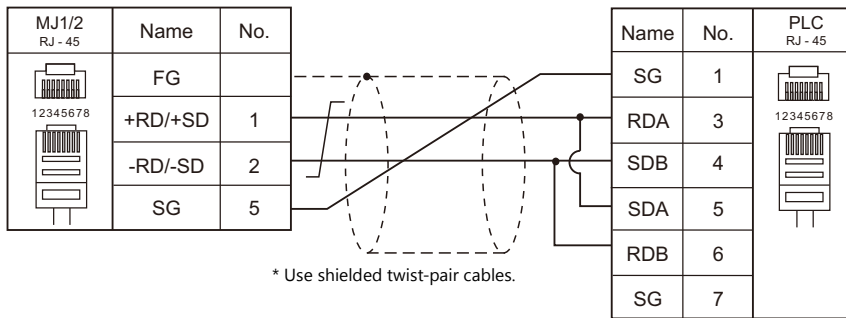

MEMO

Please use this page freely.

10. MODICON

10.1 PLC Connection

10.1 PLC Connection

Serial Connection

PLC Selection on the Editor	CPU		Unit/Port	Signal Level	Connection		Ladder Transfer ^{*1}
					CN1	MJ1/MJ2	
Modbus RTU	Quantum	140 CPU 113 02 140 CPU 113 03 140 CPU 331 10 140 CPU 434 12A 140 CPU 434 12B 140 CPU 434 12U 140 CPU 534 14U 140 CPU 651 50 140 CPU 651 60 140 CPU 671 60(HSBY)	COMM1	RS-232C	Wiring diagram 1 - C2	Wiring diagram 1 - M2	×

*1 For the ladder transfer function, see the V9 Series Reference Manual.

10.1.1 Modbus RTU

Communication Setting

Editor

Communication setting

(Underlined setting: default)

Item	Setting	Remarks
Connection Mode	<u>1-1</u> / Multi-link2 / Multi-link2 (Ethernet)	
Signal Level	<u>RS-232C</u>	
Baud Rate	4800 / <u>9600</u> / 19200 bps	
Data Length	<u>8 bits</u>	
Stop Bit	<u>1</u> / 2 bits	
Parity	None / Odd / <u>Even</u>	
Target Port No.	<u>1</u> to 247	

PLC

Communication setting

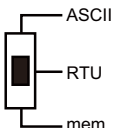
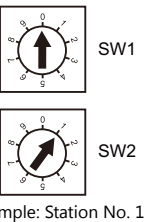
Switch	Setting	Contents	Remarks																				
	Communication setting	RTU	When the communication setting switch is set to "mem", the parameters set in the PLC programming software take effect. (Communication at 19200 bps maximum is allowed.) For more information, refer to the PLC manual issued by the manufacturer.																				
	Device address	1 to 64																					
		<table border="1"> <thead> <tr> <th>Station No. (1 to 64)</th> <th>SW1 (the tens place)</th> <th>SW2 (the ones place)</th> </tr> </thead> <tbody> <tr> <td>1 to 9</td> <td>0</td> <td>1 to 9</td> </tr> <tr> <td>10 to 19</td> <td>1</td> <td rowspan="4">0 to 9</td> </tr> <tr> <td>20 to 29</td> <td>2</td> </tr> <tr> <td>30 to 39</td> <td>3</td> </tr> <tr> <td>40 to 49</td> <td>4</td> </tr> <tr> <td>50 to 59</td> <td>5</td> <td rowspan="2">0 to 4</td> </tr> <tr> <td>60 to 64</td> <td>6</td> </tr> </tbody> </table>	Station No. (1 to 64)	SW1 (the tens place)	SW2 (the ones place)	1 to 9	0	1 to 9	10 to 19	1	0 to 9	20 to 29	2	30 to 39	3	40 to 49	4	50 to 59	5	0 to 4	60 to 64	6	
Station No. (1 to 64)	SW1 (the tens place)	SW2 (the ones place)																					
1 to 9	0	1 to 9																					
10 to 19	1	0 to 9																					
20 to 29	2																						
30 to 39	3																						
40 to 49	4																						
50 to 59	5	0 to 4																					
60 to 64	6																						

Available Device Memory

The available setting range of device memory varies depending on the PLC model. Be sure to set within the range available for the PLC to be used. Use [TYPE] when assigning indirect device memory for macro programs.

Device Memory	TYPE	Remarks
4 (holding register)	00H	
3 (input register)	01H	Read only
0 (output coil)	04H	
1 (input relay)	06H	Read only

Notes on Creating Screen Programs

On the editor, the device memory address is specified in decimal notation. Thus, when the address of a connected device is expressed in hexadecimal notation, convert the address into decimal one and add "1".

10.1.2 Wiring Diagrams

When Connected at CN1:

RS-232C

Wiring diagram 1 - C2

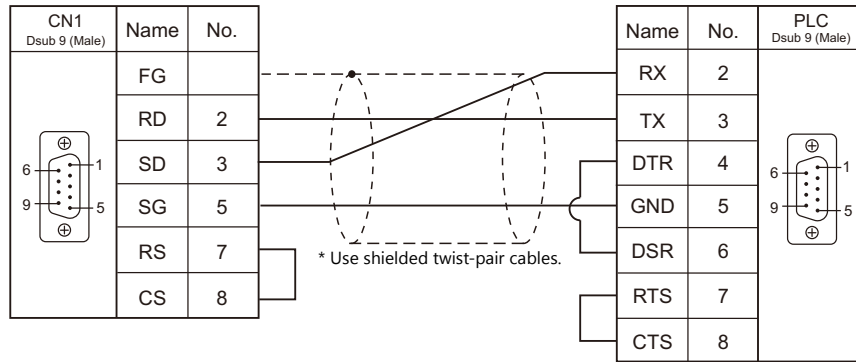

When Connected at MJ1/MJ2:

RS-232C

Wiring diagram 1 - M2

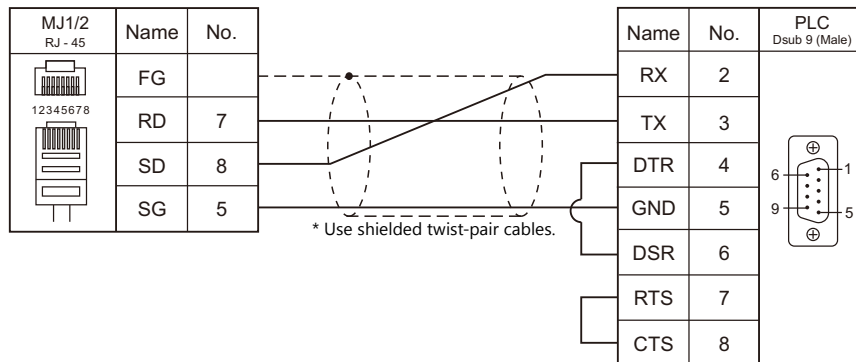

MEMO

Please use this page freely.

11. MOELLER

11.1 PLC Connection

11.1 PLC Connection

Serial Connection

PLC Selection on the Editor	CPU	Unit/Port	Signal Level	Connection		Ladder Transfer *1
				CN1	MJ1/MJ2	
PS4	PS4-141-MM1 PS4-151-MM1 PS4-201-MM1 PS4-201-MM5 PS4-271-MM1 PS4-341-MM1	PRG port	RS-232C	Wiring diagram 1 - C2 or MOELLER's "ZB4-303-KB1" + Wiring diagram 2 - C2	Wiring diagram 1 - M2 or MOELLER's "ZB4-303-KB1" + Wiring diagram 2 - M2	×

*1 For the ladder transfer function, see the V9 Series Reference Manual.

11.1.1 PS4

Communication Setting

Editor

Communication setting

(Underlined setting: default)

Item	Setting	Remarks
Connection Mode	<u>1</u> :1 / Multi-link2 / Multi-link2 (Ethernet)	
Signal Level	<u>RS-232C</u>	
Baud Rate	<u>9600</u> bps	
Data Length	<u>8</u> bits	
Stop Bit	<u>1</u> bit	
Parity	<u>None</u>	

PLC

PRG port

The communication parameters are fixed; baud rate: 9600 bps, signal level: RS-232C, data length: 8 bits, stop bit: 1 bit, parity: none.

For establishing communication with the V series, register a device memory in the PLC software "S40". For more information, refer to the PLC manual issued by the manufacturer.

Available Device Memory

The available setting range of device memory varies depending on the PLC model. Be sure to set within the range available for the PLC to be used. Use [TYPE] when assigning indirect device memory for macro programs.

Device Memory	TYPE	Remarks
MW (Merker)	00H	M as bit device ^{*1}

^{*1} The assigned device memory is expressed as shown below when editing the screen.
The addresses are expressed in "bytes". For word designation, specify an even-numbered address.

- Word device

Example: MW200

↑
Address number
(even number only)

- Bit device

Example: M200 . 0

↑ ↑
Bit number: 0 to 7
Period
Byte address number

Indirect Device Memory Designation

n+0	Model	Device type
n+1	Address No. ^{*1}	
n+2	Expansion code	Bit designation ^{*2}
n+3	00	Station number

^{*1} Word designation

Specify an address number divided by "2".

Example: In the case of MW10, specify "5" (10 divided by 2) for the address number.

^{*2} Bit designation

Example: In the case of bits 0 to 7 of MW10, specify "5" for the address number and "0" to "7" for the bit designation.

Example: In the case of bits 0 to 7 of MW11, specify "5" for the address number and "8" to "15" for the bit designation.

11.1.2 Wiring Diagrams

When Connected at CN1:

RS-232C

Wiring diagram 1 - C2

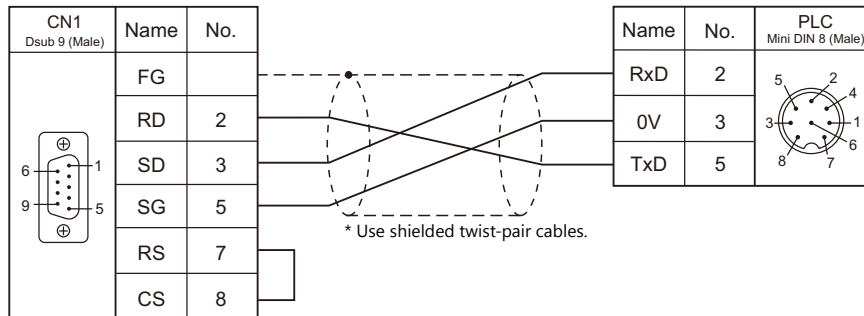

Wiring diagram 2 - C2

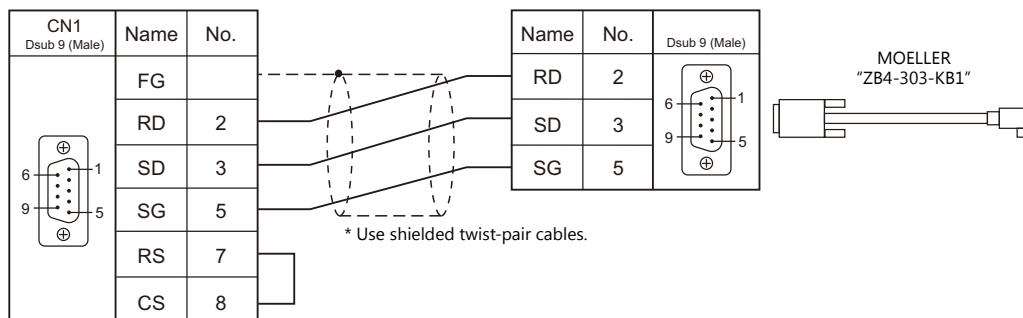

When Connected at MJ1/MJ2:

RS-232C

Wiring diagram 1 - M2

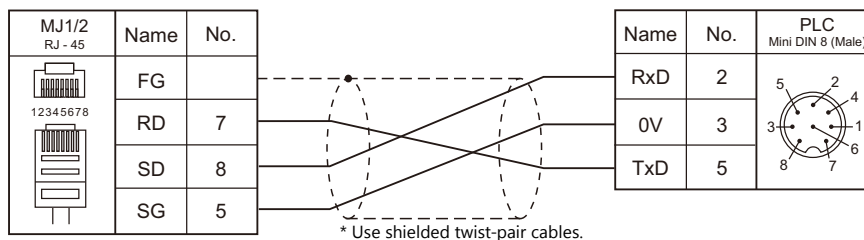

Wiring diagram 2 - M2

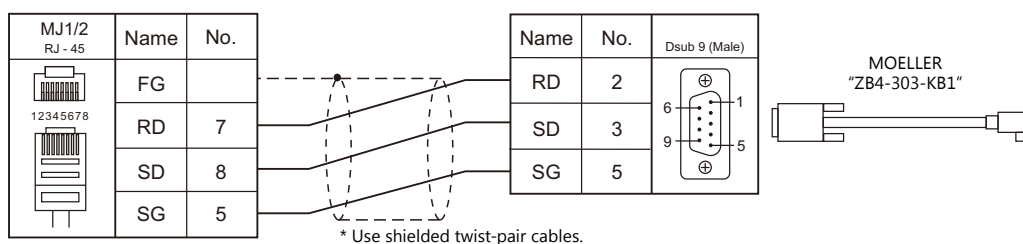

MEMO

Please use this page freely.

12. M-SYSTEM

12.1 Temperature Controller/Servo/Inverter Connection

12.1 Temperature Controller/Servo/Inverter Connection

Remote I/O

PLC Selection on the Editor	Model	Port	Signal Level	Connection		Lst File
				CN1	MJ1/MJ2	
R1M series (MODBUS RTU)	R1M series	Dsub connector	RS-232C	Wiring diagram 1 - C2	Wiring diagram 1 - M2	MSYS_R1M.Lst
		Terminal block	RS-485	Wiring diagram 1 - C4	Wiring diagram 1 - M4	

12.1.1 R1M Series

Communication Setting

Editor

Communication setting

(Underlined setting: default)

Item	Setting	Remarks
Connection Mode	1 : 1 / <u>1 : n</u> / Multi-link2 / Multi-link2 (Ethernet) / 1 : n Multi-link2 (Ethernet)	
Signal Level	RS-232C / <u>RS-422/485</u>	
Baud Rate	9600 / 19200 / <u>38400</u> bps	
Data Length	8 bits	
Stop Bit	<u>1</u> / 2 bits	
Parity	None / <u>Odd</u> / Even	
Target Port No.	1 to 15	

Remote I/O

Make PLC settings by using the software "R1CON". For more information, refer to the PLC manual issued by the manufacturer.

Modbus settings (RTU)

(Underlined setting: default)

Item	Setting	Remarks
Node Address	<u>1</u> to F H (= 1 to 15)	Set by the address setting rotary switch.
Baud Rate	9600 / 19200 / <u>38400</u> bps	
Bit Length	8 bits	
Parity	NONE / <u>ODD</u> / EVEN	
Stop Bit	<u>1</u> / 2 bits	

Available Device Memory

The available setting range of device memory varies depending on the model. Be sure to set within the range available for the model to be used. Use [TYPE] when assigning indirect device memory for macro programs.

Device Memory	TYPE	Remarks
0 (output coil)	00H	
1 (input relay)	01H	Read only
4 (holding register)	02H	
3 (input register)	03H	Read only

12.1.2 Wiring Diagrams

When Connected at CN1:

RS-232C

Wiring diagram 1 - C2

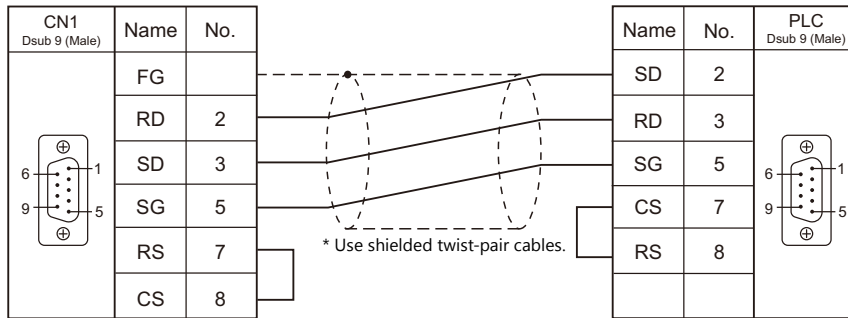

RS-422/RS-485

Wiring diagram 1 - C4

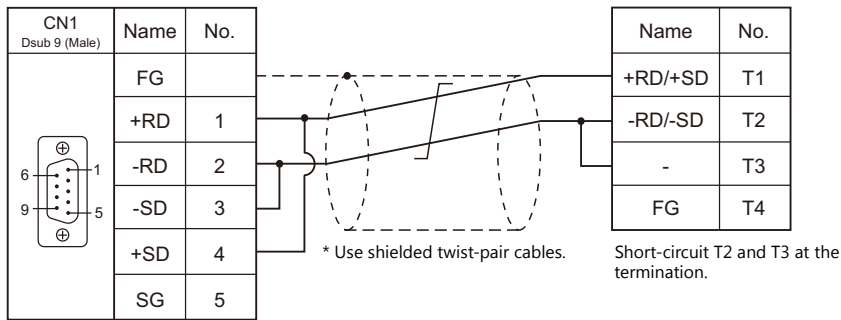

When Connected at MJ1/MJ2:

RS-232C

Wiring diagram 1 - M2

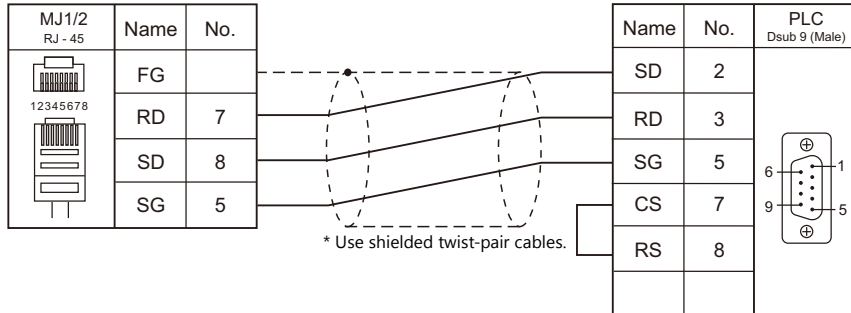

RS-422/RS-485

Wiring diagram 1 - M4

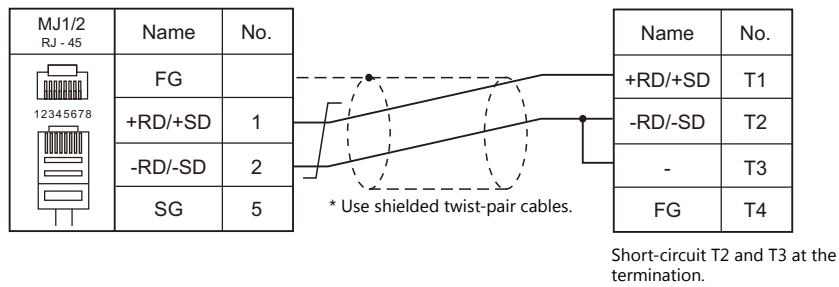

13. OMRON

- 13.1 PLC Connection
- 13.2 Temperature Controller/Servo/Inverter Connection

13.1 PLC Connection

Serial Connection

SYSMAC C/CV

PLC Selection on the Editor	CPU	Unit/Port	Signal Level	Connection		Ladder Transfer *1
				CN1	MJ1/MJ2	
SYSMAC C	C20H, C28H, C40H	RS-232C port	RS-232C	Wiring diagram 1 - C2	Wiring diagram 1 - M2	○
	C120, C120F C200H C500, C500F C1000H C2000, C2000H	C120-LK201-V1	RS-232C	Wiring diagram 3 - C2	Wiring diagram 3 - M2	
		C120-LK202-V1	RS-422	Wiring diagram 1 - C4	×	
	C200H C200HS-CPU01, 03 C200HS-CPU21, 23 C200HS-CPU31, 33	C200H-LK201 C200H-LK201-V1	RS-232C	Wiring diagram 3 - C2	Wiring diagram 3 - M2	
		C200H-LK202 C200H-LK202-V1	RS-422	Wiring diagram 1 - C4	×	
	C200HS-CPU21, 23 C200HS-CPU31, 33 CQM1-CPU21 CQM1-CPU41, 42, 43, 44	RS-232C port	RS-232C	Hakko Electronics' cable "D9-OM2-09" or Wiring diagram 2 - C2	Hakko Electronics' cable "MJ-OM209" or Wiring diagram 2 - M2	
				C500, C500F C1000H C2000, C2000H	C500-LK203	
	C200HX C200HG C200HE	RS-232C port	RS-232C	Hakko Electronics' cable "D9-OM2-09" or Wiring diagram 2 - C2	Hakko Electronics' cable "MJ-OM209" or Wiring diagram 2 - M2	
				C200HW-COM02 C200HW-COM03 C200HW-COM04 C200HW-COM05 C200HW-COM06	RS-422	
	SRM1-C02	RS-232C port	RS-232C	Hakko Electronics' cable "D9-OM2-09" or Wiring diagram 2 - C2	Hakko Electronics' cable "MJ-OM209" or Wiring diagram 2 - M2	
	CPM1A	Peripheral port	RS-232C	OMRON's [CQM1-CIF02] + Gender changer *2	OMRON's [CQM1-CIF02] + Wiring diagram 4 - M2	
	CPM2A	RS-232C port	RS-232C	Hakko Electronics' cable "D9-OM2-09" or Wiring diagram 2 - C2	Hakko Electronics' cable "MJ-OM209" or Wiring diagram 2 - M2	
		Peripheral port	RS-232C	OMRON's [CQM1-CIF02] + Gender changer *2	OMRON's [CQM1-CIF02] + Wiring diagram 4 - M2	
	CPM2C	CS1W-CN118	RS-232C	Hakko Electronics' cable "D9-OM2-09" or Wiring diagram 2 - C2	Hakko Electronics' cable "MJ-OM209" or Wiring diagram 2 - M2	
				CPM2C-CIF01	Wiring diagram 2 - C2	
CPM2C-CIF11		RS-422	Wiring diagram 4 - C4	×		
SYSMAC CV	CV500 CV1000 CV2000 CVM1	Host link port incorporated into CPU	RS-232C	Hakko Electronics' cable "D9-OM2-09" or Wiring diagram 2 - C2	Hakko Electronics' cable "MJ-OM209" or Wiring diagram 2 - M2	×
			RS-422	Wiring diagram 5 - C4	×	
		CV500-LK201	RS-232C PORT1	Wiring diagram 3 - C2	Wiring diagram 3 - M2	
			RS-232C PORT2	Hakko Electronics' cable "D9-OM2-09" or Wiring diagram 2 - C2	Hakko Electronics' cable "MJ-OM209" or Wiring diagram 2 - M2	
			RS-422	Wiring diagram 2 - C4	×	

*1 For the ladder transfer function, see the V9 Series Reference Manual.

*2 Use a D-sub gender changer (9-pin, female-to-male) commercially available.

Manufacturer	Model
Black Box	FA440-R2
Misumi	DGC-9PP

SYSMAC CS1/CJ1

PLC Selection on the Editor	CPU	Unit/Port	Signal Level	Connection		Ladder Transfer *1	
				CN1	MJ1/MJ2		
SYSMAC CS1/CJ1 SYSMAC CS1/CJ1 DNA	CS1	RS-232C port	RS-232C	Hakko Electronics' cable "D9-OM2-09" or Wiring diagram 2 - C2	Hakko Electronics' cable "MJ-OM209" or Wiring diagram 2 - M2	○	
		CS1W-SCU21 CS1W-SCU21-V1					
		CS1W-SCU31-V1	RS-422	Wiring diagram 3 - C4	×		
		CS1W-SCB21 CS1W-SCB21-V1	RS-232C	Hakko Electronics' cable "D9-OM2-09" or Wiring diagram 2 - C2	Hakko Electronics' cable "MJ-OM209" or Wiring diagram 2 - M2		
		CS1W-SCB41 CS1W-SCB41-V1		Port 1	RS-422		Wiring diagram 3 - C4
		CS1W-SCB41 CS1W-SCB41-V1	Port 2	RS-422	Wiring diagram 3 - C4		×
	CJ1H CJ1M	RS-232C port	RS-232C	Hakko Electronics' cable "D9-OM2-09" or Wiring diagram 2 - C2	Hakko Electronics' cable "MJ-OM209" or Wiring diagram 2 - M2		
		CJ1W-SCU21 CJ1W-SCU21-V1 CJ1W-SCU22					
		CJ1W-SCU31-V1	RS-422	Wiring diagram 3 - C4	×		
		CJ1W-SCU32	RS-422	Wiring diagram 4 - C4	×		
		CJ1W-SCU41 CJ1W-SCU41-V1	Port 1	RS-422	Wiring diagram 3 - C4		×
			Port 2	RS-232C	Hakko Electronics' cable "D9-OM2-09" or Wiring diagram 2 - C2		Hakko Electronics' cable "MJ-OM209" or Wiring diagram 2 - M2
		CJ1W-SCU42	Port 1	RS-422	Wiring diagram 4 - C4		×
			Port 2	RS-232C	Hakko Electronics' cable "D9-OM2-09" or Wiring diagram 2 - C2		Hakko Electronics' cable "MJ-OM209" or Wiring diagram 2 - M2
		CJ2H CJ2M	RS-232C port *2	RS-232C	Hakko Electronics' cable "D9-OM2-09" or Wiring diagram 2 - C2		Hakko Electronics' cable "MJ-OM209" or Wiring diagram 2 - M2
			CP1W-CIF01 *3				
			CP1W-CIF11 *3 CP1W-CIF12 *3	RS-422	Wiring diagram 4 - C4		Wiring diagram 1 - M4
			CJ1W-SCU21 CJ1W-SCU21-V1 CJ1W-SCU22	RS-232C	Hakko Electronics' cable "D9-OM2-09" or Wiring diagram 2 - C2		Hakko Electronics' cable "MJ-OM209" or Wiring diagram 2 - M2
	CJ1W-SCU31-V1		RS-422		Wiring diagram 3 - C4		×
	CJ1W-SCU32		RS-422	Wiring diagram 4 - C4	×		
	CJ1W-SCU41 CJ1W-SCU41-V1		Port 1	RS-422	Wiring diagram 3 - C4		×
			Port 2	RS-232C	Hakko Electronics' cable "D9-OM2-09" or Wiring diagram 2 - C2		Hakko Electronics' cable "MJ-OM209" or Wiring diagram 2 - M2
	CJ1W-SCU42		Port 1	RS-422	Wiring diagram 4 - C4		×
			Port 2	RS-232C	Hakko Electronics' cable "D9-OM2-09" or Wiring diagram 2 - C2		Hakko Electronics' cable "MJ-OM209" or Wiring diagram 2 - M2
	CP1E (N/NA) *4 CP1H CP1L		RS-232C port *5	RS-232C	Hakko Electronics' cable "D9-OM2-09" or Wiring diagram 2 - C2		Hakko Electronics' cable "MJ-OM209" or Wiring diagram 2 - M2
			CP1W-CIF01				
		CP1W-CIF11 CP1W-CIF12	RS-422	Wiring diagram 4 - C4	Wiring diagram 1 - M4		

*1 For the ladder transfer function, see the V9 Series Reference Manual.

*2 No built-in serial communication port is provided for CJ2M-3x.

*3 Can be used only with CJ2M-3x.

*4 CP1E (E type) cannot be connected because it is not equipped with a built-in serial communication port and the optional board cannot be installed on it.

*5 Only CP1E (N/NA type) is equipped with the built-in serial communication port.

Ethernet Connection

SYSMAC CS1/CJ1

PLC Selection on the Editor	CPU	Unit	TCP/IP	UDP/IP	Port No.	Keep Alive ^{*1}	Ladder Transfer ^{*2}
SYSMAC CS1/CJ1 (Ethernet) SYSMAC CS1/CJ1 (Ethernet Auto) SYSMAC CS1/CJ1 DNA (Ethernet)	CS1	CS1W-ETN01 CS1W-ETN11 CS1W-ETN21	×	○	9600	○	×
	CJ1	CJ1W-ETN11 CJ1W-ETN21					

*1 For KeepAlive functions, see "1.3.2 Ethernet Communication".

*2 For the ladder transfer function, see the V9 Series Reference Manual.

13.1.1 SYSMAC C

Communication Setting

Editor

Communication setting

(Underlined setting: default)

Item	Setting	Remarks
Connection Mode	1 : 1 / <u>1 : n</u> / Multi-link2 / Multi-link2 (Ethernet) / 1 : n Multi-link2 (Ethernet)	
Signal Level	<u>RS-232C</u> / RS-422/485	
Baud Rate	4800 / 9600 / <u>19200</u> bps	
Data Length	<u>7</u> / 8 bits	
Stop Bit	1 / <u>2</u> bits	
Parity	None / Odd / <u>Even</u>	
Target Port No.	<u>0</u> to 31	
Transmission Mode	<u>Transmission Mode 1</u> / Transmission Mode 2	Transmission Mode 1: BCD without signs Transmission Mode 2: BCD with signs

Transmission mode 2

When the transmission mode 2 (BCD with signs) is selected, data in the PLC device memory can be displayed on MONITOUCH as data with signs.

When higher 4 bits in the device memory indicates [F] or [A], it is treated as negative.

[F]: Regards higher 4 bits as [-0].

[A]: Regards higher 4 bits as [-1].

- Displayable range 1 word: -1999 to +9999
2 words: -19999999 to +99999999

Example:

PLC Device Memory	Indication on the V Series
0000 to 9999	0 to 9999
F001 to F999	-1 to -999
A000 to A999	-1000 to -1999
00000000 to 99999999	0 to 99999999
F0000001 to F9999999	-1 to -9999999
A0000000 to A9999999	-10000000 to -19999999

- Setting procedure: Num. Display [Input Type: BCD]
[Display Type: DEC] (w/ sign -, w/ sign +-)

PLC

C20H / C28H / C40H**Standard setting**

Item	Setting	Remarks
Start Bit	1 bit	Communication parameter format can be specified in the DM920 to DM923 device memory. For more information, refer to the PLC manual issued by the manufacturer.
Data Length	7 bits	
Parity	Even	
Stop Bit	2 bits	
Baud Rate	9600 bps	

C120-LK201-V1 / C120-LK202-V1**Switch setting**

Switch	No.	Setting	Contents
SW1	1 to 5	OFF	Unit No. 0
	6 to 7	OFF	Not used
	8	ON	Starts operation at power-up
SW2	1	OFF	19200 bps
	2	OFF	
	3	ON	
	4	OFF	
	5	OFF	Not used
	6	OFF	1 : n protocol
	7	ON	Disables command levels 1, 2, and 3
	8	ON	
SW3	1	ON	CTS switch: always ON
	2	OFF	
	3	ON	
	4	OFF	LK201-V1: internal synchronization LK202-V1: terminating resistance provided
	5	ON	
	6	OFF	
	7 to 8	OFF	

The communication parameter setting is fixed to 7 bits for data length, 2 bits for stop bit, and even for parity.

C200H-LK201-V1 / C200H-LK202-V1**Front switch setting**

Switch	Setting	Contents
SW1	0	Higher-order digit of the unit No. (×10)
SW2	0	Lower-order digit of the unit No. (×1)
SW3	6	19200 bps
SW4	2	Disables command levels 1, 2 and 3 / 7 / 2 / even

Back switch setting

Unit	Switch	Setting	Contents
LK201	SW1	OFF	Not used
	SW2	OFF	
	SW3	ON	1 : n protocol
	SW4	OFF	5-V power not supplied
	CTS switch	0	0 V (always ON)
LK202	Terminating resistance	ON	Provided
	Protocol	OFF	1 : n protocol

C500H-LK203**Back switch setting**

Switch	Setting	Contents	
5-V power supply	OFF		
I/O port	-	RS-232C/RS422	
Synchronization	Internal		
Terminating resistance	Provided	Applicable for RS-422	
CTS	0V	0 V	
SW1	1 to 5	OFF	Unit No. 0
	6	OFF	7 / 2 / even
	7	OFF	
	8	ON	Monitor
SW2	1	OFF	19200 bps
	2	OFF	
	3	ON	
	4	OFF	
	5	ON	System No. 0
	6	OFF	1 : n protocol
	7	ON	Disables levels 1, 2, and 3
	8	ON	

C200HX / C200HG / C200HE**DIP switch**

Item	Setting		Remarks
SW5	ON	Standard setting	7, 2, E, 9600 bps, Unit No. 0
	OFF	PC system setting	<p>Communication settings are made by setting DM6645 to 6648. For more information, refer to the PLC manual issued by the manufacturer.</p> <p>Setting example</p> <p>DM6645: "0001H" Communication is performed according to the setting for DM6646.</p> <p>DM6646: "0304H" 7, 2, E, 19200 bps</p> <p>DM6648: "0000H" Unit No. 0</p>

C200HW-COM02 - 06**DIP switch**

For the port A of C200HW-CCM03/06 (RS-422), the DIP switch setting is available.

DIP Switch	Contents	Setting
SW1	Change-over of 2-wire or 4-wire system	4 (4-wire system)
SW2	Terminator	ON

PLC system setting

Item	Setting	Remarks
User Setting	Checked	The system setting can be made by specifying a value for the address using a programming console. For more information, refer to the PLC manual issued by the manufacturer.
Baud Rate	4800 / 9600 / 19200	
Parameter	1, 7, 2, E	
Mode	Host link	
Unit No.	00	

CPM2A**Communication condition setting switch**

Communication Condition Setting Switch	Setting	Contents
	OFF	The peripheral port and RS-232C port are operated according to the communication protocol and communication format set on the PLC system setting.

PLC system setting

Item	Setting	Remarks
User Setting	Checked	The system setting can be made by specifying a value for the address using a programming console. For more information, refer to the PLC manual issued by the manufacturer.
Baud Rate	4800 / 9600 / 19200	
Parameter	1, 7, 2, E	
Mode	Host link	
Unit No.	00	

CPM1A/CPM2C**Communication port function setting switch (only for CPM2C)**

Communication Port Function Setting Switch	Setting	Contents
	OFF	The RS-232C port is operated according to the communication protocol and communication format set on the PLC system setting.

PLC system setting (peripheral port)

Item	Setting	Remarks
User Setting	Checked	The system setting can be made by specifying a value for the address using a programming console. For more information, refer to the PLC manual issued by the manufacturer.
Baud Rate	4800 / 9600 / 19200	
Parameter	1, 7, 2, E	
Mode	Host link	
Unit No.	00	

Available Device Memory

The available setting range of device memory varies depending on the PLC model. Be sure to set within the range available for the PLC to be used. Use [TYPE] when assigning indirect device memory for macro programs.

Device Memory	TYPE	Remarks
DM (data memory)	00H	
CH (input/output/internal auxiliary relay)	01H	
HR (holding relay)	02H	
LR (link relay)	03H	
AR (auxiliary memory relay)	04H	
T (timer/current value)	05H	
C (counter/current value)	06H	
EMn (extended data memory)	07H	*1
TU (timer/contact)	09H	Read only
CU (counter/contact)	0AH	Read only

*1 When using EMn (extended data memory), specify the bank number 0 to 7. The assigned device memory is expressed as shown on the right when editing the screen.

Example: EM0 : 30000

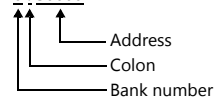

Indirect Device Memory Designation

- EMn (extended data memory)
Specify the bank number 0 to 7 in the expansion code.

13.1.2 SYSMAC CV

Communication Setting

Editor

Communication setting

(Underlined setting: default)

Item	Setting	Remarks
Connection Mode	1 : 1 / <u>1 : n</u> / Multi-link2 / Multi-link2 (Ethernet) / 1 : n Multi-link2 (Ethernet)	
Signal Level	<u>RS-232C</u> / RS-422	
Baud Rate	4800 / 9600 / <u>19200</u> bps	
Data Length	<u>7</u> / 8 bits	
Stop Bit	1 / <u>2</u> bits	
Parity	None / Odd / <u>Even</u>	
Target Port No.	<u>0</u> to 31	
Transmission Mode	<u>Transmission Mode 1</u> / Transmission Mode 2	Transmission Mode 1: BCD without signs Transmission Mode 2: BCD with signs

Transmission mode 2

When the transmission mode 2 (BCD with signs) is selected, data in the PLC device memory can be displayed on MONITOUCH as data with signs.

When higher 4 bits in the device memory indicates [F] or [A], it is treated as negative.

[F]: Regards higher 4 bits as [-0].

[A]: Regards higher 4 bits as [-1].

- Displayable range 1 word: -1999 to +9999
2 words: -19999999 to +99999999

Example:

PLC Device Memory	Indication on the V Series
0000 to 9999	0 to 9999
F001 to F999	-1 to -999
A000 to A999	-1000 to -1999
00000000 to 99999999	0 to 99999999
F0000001 to F9999999	-1 to -9999999
A0000000 to A9999999	-10000000 to -19999999

- Setting procedure: Num. Display [Input Type: BCD]
[Display Type: DEC] (w/ sign -, w/ sign +-)

PLC

CPU Unit

Communication selector switch

Communication Selector Switch	Setting
	Upper: RS-232C Lower: RS-422

Basic setting DIP switch

DIP Switch	Setting	Remarks
	No. 3	OFF: Host link communication
	No. 4	OFF: The host communication port is operated according to the communication condition set on the PLC system setting. ON: Fixed to 9600 bps for baud rate, 0 for station number, 7 bits for data length, 2 bits for stop bit and even parity
	No. 6	ON: With terminating resistance Invalid during RS-232C communication

PLC system setting (host link port)

Item	Setting	Remarks
Port Setting	Default Setting	Unchecked
	Baud Rate	4800 / 9600 / 19200
	Parameter	7, 2, E
Unit No.	00	The system setting can be made by specifying a value for the address using a programming console. For more information, refer to the PLC manual issued by the manufacturer.

Host Link Unit

Communication selector switch

Communication Selector Switch	Setting
	Communication port 2 Upper: RS-232C Lower: RS-422

Unit No. selector switch

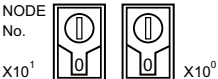
Unit No. Selector Switch	Setting
	Communication port 2 Unit No.: 00 to 31 (DEC)

Basic setting DIP switch

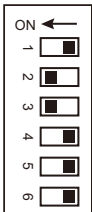
DIP Switch	Setting	Remarks
	No. 1	OFF: The link unit is operated according to the communication condition set on the CPU advanced unit system setting. ON: Fixed to 9600 bps for baud rate, 0 for station number, 7 bits for data length, 2 bits for stop bit and even parity CPU fixed
	No. 2	ON: Switching CTS for communication port 1
	No. 3	ON: Switching CTS for communication port 2 Invalid during RS-422 communication
	No. 4	OFF: Not used
	No. 5	OFF: Normal operation

CPU advanced unit system setting

Set parameters for communication port 1 or 2.

Available Device Memory

The available setting range of device memory varies depending on the PLC model. Be sure to set within the range available for the PLC to be used. Use [TYPE] when assigning indirect device memory for macro programs.

Device Memory	TYPE	Remarks
DM (data memory)	00H	
CH (input/output/internal auxiliary relay)	01H	
AR (auxiliary memory relay)	04H	
T (timer/current value)	05H	
C (counter/current value)	06H	
EMn (extended data memory)	07H	*1
TU (timer/contact)	09H	Read only
CU (counter/contact)	0AH	Read only

*1 When using EMn (extended data memory), specify the bank number 0 to 7. The assigned device memory is expressed as shown on the right when editing the screen.

Example: EM0 : 30000

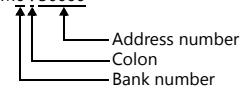

Indirect Device Memory Designation

- EMn (extended data memory)
Specify the bank number 0 to 7 in the expansion code.

13.1.3 SYSMAC CS1/CJ1

Communication Setting

Editor

Communication setting

(Underlined setting: default)

Item	Setting	Remarks
Connection Mode	1 : 1 / <u>1 : n</u> / Multi-link2 / Multi-link2 (Ethernet) / 1 : n Multi-link2 (Ethernet)	
Signal Level	<u>RS-232C</u> / RS-422/485	
Baud Rate	4800 / 9600 / <u>19200</u> / 38400 / 57600 / 115k bps	
Data Length	<u>7</u> / 8 bits	
Stop Bit	1 / <u>2</u> bits	
Parity	None / Odd / <u>Even</u>	
Target Port No.	<u>0</u> to 31	
Transmission Mode	<u>Transmission Mode 1</u> / Transmission Mode 2	Transmission Mode 1: BCD without signs Transmission Mode 2: BCD with signs

Transmission mode 2

When the transmission mode 2 (BCD with signs) is selected, data in the PLC device memory can be displayed on MONITOUCH as data with signs.

When higher 4 bits in the device memory indicates [F] or [A], it is treated as negative.

[F]: Regards higher 4 bits as [-0].

[A]: Regards higher 4 bits as [-1].

- Displayable range 1 word: -1999 to +9999
2 words: -19999999 to +99999999

Example:

PLC Device Memory	Indication on the V Series
0000 to 9999	0 to 9999
F001 to F999	-1 to -999
A000 to A999	-1000 to -1999
00000000 to 99999999	0 to 99999999
F0000001 to F9999999	-1 to -9999999
A0000000 to A9999999	-10000000 to -19999999

- Setting procedure: Num. Display [Input Type: BCD]
[Display Type: DEC] (w/ sign -, w/ sign +-)

PLC

CJ1/CS1/CJ2 (Built-in RS-232C Port / CP1W-CIFxx)

DIP switch

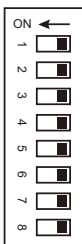
Switch	Contents	Setting
	SW1	User memory writing
	SW2	Automatic user program transfer at power-up
	SW3	CJ1/CJ2: Blank CS1: message of the programming console (Japanese/English)
	SW4	CJ2: Blank CS1/CJ1: peripheral port communication condition
	SW5	RS-232C communication setting
	SW6	User-specified switch
	SW7	Simple-backup type specification
	SW8	Fixed to OFF
		OFF: enabled OFF: not executed OFF OFF: CX-Programmer connection OFF: According to the setting made on the PLC system setting OFF OFF OFF

PC system setting

Item	Setting	Remarks
User Setting	Checked	The system setting can be made by specifying a value for the address using a programming console. For more information, refer to the PLC manual issued by the manufacturer.
Baud Rate	4800 / 9600 / 19200 / 38400 / 57600 / 115200	
Parameter	7, 2, E	
Mode	Host link	
Unit No.	00	

CP1W-CIF11/12 DIP switch

Make the operation setting for the RS-422/485 optional board (CP1W-CIF11/12) by using the DIP switch provided on the backside.

Switch	Contents	Setting
 SW1	Terminating resistance	ON: Provided
SW2	2-wire / 4-wire selection	ON: 2-wire system OFF: 4-wire system
SW3	2-wire / 4-wire selection	ON: 2-wire system OFF: 4-wire system
SW4	Not used	OFF
SW5	RS control for RD	OFF: Without control
SW6	RS control for SD	ON: With control (when 2-wire system is selected) OFF: Without control (when 4-wire system is selected)

CJ1/CS1/CJ2 (Serial Communication Board/Unit)

Advanced unit setting

Item	Setting	Remarks
Random Setting	Provided	
Serial Communication Mode	Default (host link) / Host link	When "Default (host link)" is selected, the unit operates as the unit No. 0.
Data Length	7 bits / 8 bits	
Stop Bit	2 bits / 1 bit	
Parity	Even, odd, none	
Baud Rate	4800 / 9600 / 19200 / 38400 / 57600 / 115200	
Send Delay Time	Default: 0 ms	
Send Delay Time Random Setting	0	
CTS control	None	
Host link unit No.	00	

DM area setting

m = D30000 + 100 x unit No. (CH)

DM Area				Bit	Contents	Setting
Board		Unit				
Port 1	Port 2	Port 1	Port 2			
D32000	D32010	m	m + 10	15	Port setting	1: Random setting
				14 to 12	Reserved	-
				11 to 08	Host link	0 or 5
				07 to 05	Reserved	-
				04	Start bit	0: 1 bit
				03	Data length	0: 7 bits 1: 8 bits
				02	Stop bit	0: 2 bits 1: 1 bit
				01	Parity	0: Provided 1: None
00	Parity	0: Even 1: Odd				

DM Area				Bit	Contents	Setting
Board		Unit				
Port 1	Port 2	Port 1	Port 2			
D32001	D32011	m + 1	m + 11	15 to 04	Reserved	-
				03 to 00	Baud rate	0: 9600 5: 4800 6: 9600 7: 19200 8: 38400 9: 57600 A: 115200
D32002	D32012	m + 2	m + 12	15	Send delay time	0: 0 ms 1: Random setting
				14 to 00	Send delay time random setting	0 to 7530H Unit: 10 ms
D32003	D32013	m + 3	m + 13	15	CTS control	0: None 1: Provided
				14	1 : n/1 : 1 protocol setting	1 : 1 : 1 protocol 0 : 1 : n protocol
				13 to 11	Reserved	-
				10 to 08	Host link-compatible model mode	
				07 to 00	Unit No.	00 to 1FH

CP1 (Built-in RS-232C Port / CP1W-CIFxx)

CPU DIP switch

Set the communication conditions for the CP1H/CP1L optional board slot by using the CPU DIP switch.

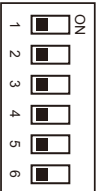
Switch	Contents	Setting
	SW4	Optional slot 1 communication condition
	SW5	Optional slot 2 communication condition
		OFF: According to the setting made on the PLC system setting
		OFF: According to the setting made on the PLC system setting

PLC system setting

Item	Setting	Remarks
User Setting	Checked	The system setting can be made by specifying a value for the address using a programming console. For more information, refer to the PLC manual issued by the manufacturer.
Baud Rate	4800 / 9600 / 19200 / 38400 / 57600 / 115200	
Parameter	7, 2, E	
Mode	Host link	
Unit No.	00 to 31	

CP1W-CIF11/12 DIP switch

Make the operation setting for the RS-422/485 optional board (CP1W-CIF11/12) by using the DIP switch provided on the backside.

Switch	Contents	Setting
	SW1	Terminating resistance
	SW2	2-wire / 4-wire selection
	SW3	2-wire / 4-wire selection
	SW4	Not used
	SW5	RS control for RD
	SW6	RS control for SD
		ON: Provided
		ON: 2-wire system OFF: 4-wire system
		ON: 2-wire system OFF: 4-wire system
		OFF
		OFF: Without control
		ON: With control (when 2-wire system is selected) OFF: Without control (when 4-wire system is selected)

Available Device Memory

The available setting range of device memory varies depending on the PLC model. Be sure to set within the range available for the PLC to be used. Use [TYPE] when assigning indirect device memory for macro programs.

Device Memory	TYPE	Remarks
DM (data memory)	00H	
CH (input/output/internal auxiliary relay)	01H	
H (holding relay)	02H	
A (auxiliary memory relay)	04H	
T (timer/current value)	05H	
C (counter/current value)	06H	
EMn (extended data memory)	07H	*1, not available on the CP1 series
W (internal relay)	08H	
TU (timer/contact)	09H	Read only
CU (counter/contact)	0AH	Read only

*1 When using EMn (extended data memory), specify the bank number 0 to 18 (HEX).
The assigned device memory is expressed as shown on the right when editing the screen.

example: EM0 : 30000

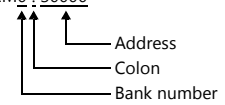

Indirect Device Memory Designation

- EMn (extended data memory)
Specify the bank number 0 to 18 (HEX) in the expansion code.

13.1.4 SYSMAC CS1/CJ1 (DNA)

The V9 series can communicate with CS1/CJ1 on the network (Controller Link) via the serial unit.

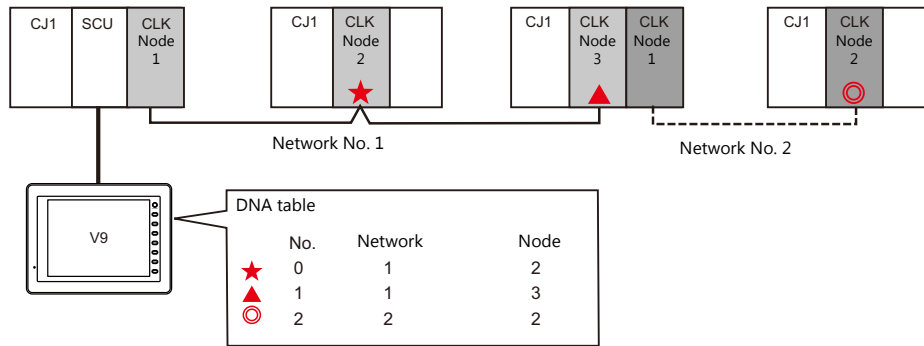

Communication Setting

Editor

Communication settings

The communication setting is the same as the one described in "13.1.3 SYSMAC CS1/CJ1".

DNA

[System Setting] → [Hardware Setting] → [PLC Properties] → [DNA]

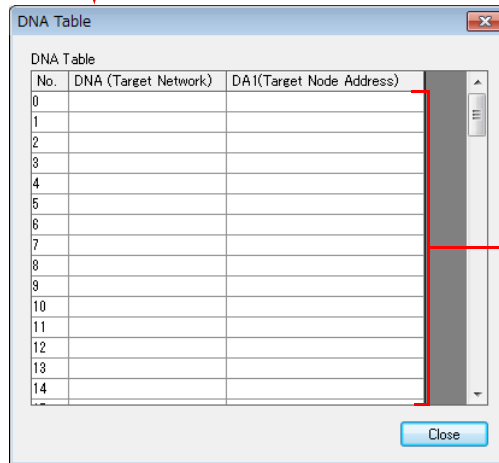
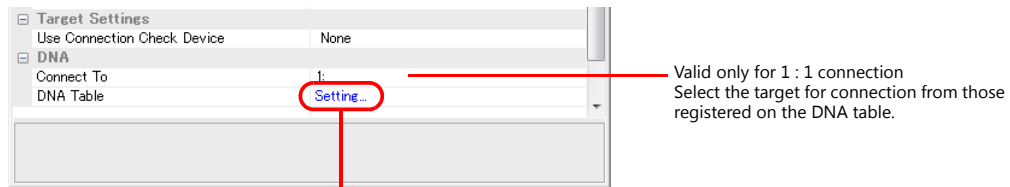

Item	Setting
DNA	Set the network number of the communication target.
DA1	Set the node address of the communication target.

PLC

Communication setting

The communication setting is the same as the one described in "13.1.3 SYSMAC CS1/CJ1".

CX-Integrator

Set the PLC routing table on "CX-Integrator". Two types of routing tables are available: local network table and relay network table.

An error will occur unless these settings are made correctly. For more information, refer to the PLC manual issued by the manufacturer.

- Local network table
Set the unit number and network number of the communication unit.
- Relay network table
Set the network number of the access target (final network No.) and the first relay point (relay network No., relay node No.).

Rotary switch

Switch	Setting
NODE No.	Set the node number of the Controller Link unit.

Available Device Memory

The available device memory is the same as the one described in "13.1.3 SYSMAC CS1/CJ1".

13.1.5 SYSMAC CS1/CJ1 (Ethernet)

Communication Setting

Editor

Make the following settings on the editor. For more information, see "1.3.2 Ethernet Communication".

- IP address for the V9 unit
 - When specified on the screen program:
[System Setting] → [Hardware Setting] → [Local Port IP Address]
 - When specified on the V9 unit:
Local mode → [LAN Setting]
- Port number for the V9 unit (for communication with PLC) and node address
[System Setting] → [Hardware Setting] → [PLC Properties] → [Communication Setting]

Communication Setting	
Connection Mode	1:1
Retrials	3
Time-out Time(*10msec)	500
Send Delay Time(*msec)	0
Start Time(*sec)	0
Transmission Mode	Transmission Mode 1
Node Address	2
Port No.	9600
Code	DEC
Text Process	LSB->MSB
Comm. Error Handling	Stop
Detail	
Priority	1
System memory(\$\$) V7 Compatible	None
Target Settings	
Connect To	1:192.168.1.100(PLC)
PLC Table	Setting...
Use Connection Check Device	None

Set the node number of the V9.

Set the same number as the V9 node number specified for [IP Address Table] on the PLC.

Set the same number as the one specified for [FINS/UDP Port] on the PLC.

- IP address and port number of the PLC
Register on the [PLC Table] in [System Setting] → [Hardware Setting] → [PLC Properties] → [Target Settings].

Target Settings	
Connect To	1:192.168.1.100(PLC)
PLC Table	Setting...
Use Connection Check Device	None

Valid only for 1 : 1 connection
Select the PLC for connection from those registered on the PLC table.

No.	Port Name	IP Address	Port No.
0			
1	PLC	192.168.1.100	9600
2			
3			
4			
5			
6			
7			
8			
9			
10			
11			
12			
13			

PLC table No. = PLC node address

Set the IP address, port number and whether or not to use the KeepAlive function to the same number as the PLC node address.

PLC

Make the following settings on CX Programmer. For more information, refer to the PLC manual issued by the manufacturer.

Parameter setting

Item	Setting
IP Address	IP address of the PLC
Subnet Mask	Subnet mask of the PLC
IP Address Conversion	IP address table
IP Address Table	IP address and node number of the PLC IP address and node number of the V9
FINS/UDP Port	Default (9600)

Rotary switch

Switch	Setting
NODE No.	Set the FINS node number of the Ethernet unit. Match the node number to the one registered in the IP address table.

Available Device Memory

The available setting range of device memory varies depending on the PLC model. Be sure to set within the range available for the PLC to be used. Use [TYPE] when assigning indirect device memory for macro programs.

Device Memory	TYPE	Remarks
DM (data memory)	00H	
CH (input/output/internal auxiliary relay)	01H	
H (holding relay)	02H	
A (auxiliary memory relay)	04H	
T (timer/current value)	05H	
C (counter/current value)	06H	
EMn (extended data memory)	07H	*1
W (internal relay)	08H	
TU (timer/contact)	09H	Read only
CU (counter/contact)	0AH	Read only

*1 When using EMn (extended data memory), specify the bank number 0 to C (HEX).
The assigned device memory is expressed as shown on the right when editing the screen.

Example: EM0 : 30000

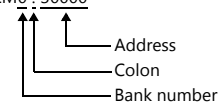

Indirect Device Memory Designation

- EMn (extended data memory)
Specify the bank number 0 to C (HEX) in the expansion code.

13.1.6 SYSMAC CS1/CJ1 (Ethernet Auto)

Communication Setting

Editor

Make the following settings on the editor. For more information, see "1.3.2 Ethernet Communication".

- IP address for the V9 unit
 - When specified on the screen program:
[System Setting] → [Hardware Setting] → [Local Port IP Address]
 - When specified on the V9 unit:
Local mode → [LAN Setting]
- Port number for the V9 unit (for communication with PLC)
[System Setting] → [Hardware Setting] → [PLC Properties] → [Communication Setting]

PLC1 Properties OMRON SYSMAC CS1/CJ1(Ethernet Auto)

Communication Setting	
Connection Mode	1:1
Retrials	3
Time-out Time(*10msec)	500
Send Delay Time(*msec)	0
Start Time(*sec)	0
Transmission Mode	Transmission Mode 1
Port No.	9600
Code	DEC
Text Process	LSB->MSB
Comm. Error Handling	Stop
Detail	
Priority	1
System memory(\$s) V7 Compatible	None
Target Settings	
Connect To	1:192.168.1.100(PLC)
PLC Table	Setting...
Use Connection Check Device	None

Set the same number as the one specified for [FINS/UDP Port] on the PLC.

- IP address and port number of the PLC
Register on the [PLC Table] in [System Setting] → [Hardware Setting] → [PLC Properties] → [Target Settings].

System memory(\$s) V7 Compatible		None
Target Settings		
Connect To	1:192.168.1.100(PLC)	
PLC Table	Setting...	
Use Connection Check Device	None	

Valid only for 1 : 1 connection
Select the PLC for connection from those registered on the PLC table.

No.	Port Name	IP Address	Port No.
0			
1	PLC	192.168.1.100	9600
2			
3			
4			
5			
6			
7			
8			
9			
10			
11			
12			
13			

Close

Set the IP address, port number and whether or not to use the KeepAlive function of the PLC.

PLC

Make the following settings on CX Programmer. For more information, refer to the PLC manual issued by the manufacturer.

Parameter setting

Item	Setting
IP Address (FINS node address)	IP address of the PLC Set the same number as the node number of the rotary switch for the lowest byte which is to be the FINS node address.
Subnet Mask	Subnet mask of the PLC
IP Address Conversion	Automatic generation (dynamic)
FINS/UDP Port	Default (9600)

Rotary switch

Switch	Setting
NODE No.	Set the FINS node number of the Ethernet unit. Match the node number to the lower byte of the IP address.

Available Device Memory

The available setting range of device memory varies depending on the PLC model. Be sure to set within the range available for the PLC to be used. Use [TYPE] when assigning indirect device memory for macro programs.

Device Memory	TYPE	Remarks
DM (data memory)	00H	
CH (input/output/internal auxiliary relay)	01H	
H (holding relay)	02H	
A (auxiliary memory relay)	04H	
T (timer/current value)	05H	
C (counter/current value)	06H	
EMn (extended data memory)	07H	*1
W (internal relay)	08H	
TU (timer/contact)	09H	Read only
CU (counter/contact)	0AH	Read only

*1 When using EMn (extended data memory), specify the bank number 0 to C (HEX). The assigned device memory is expressed as shown on the right when editing the screen.

Example: EM0 : 30000

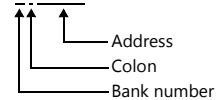

Indirect Device Memory Designation

- EMn (extended data memory)
Specify the bank number 0 to C (HEX) in the expansion code.

13.1.7 SYSMAC CS1/CJ1 DNA (Ethernet)

The V9 series can communicate with CS1/CJ1 on the network (Controller Link) via the Ethernet unit.

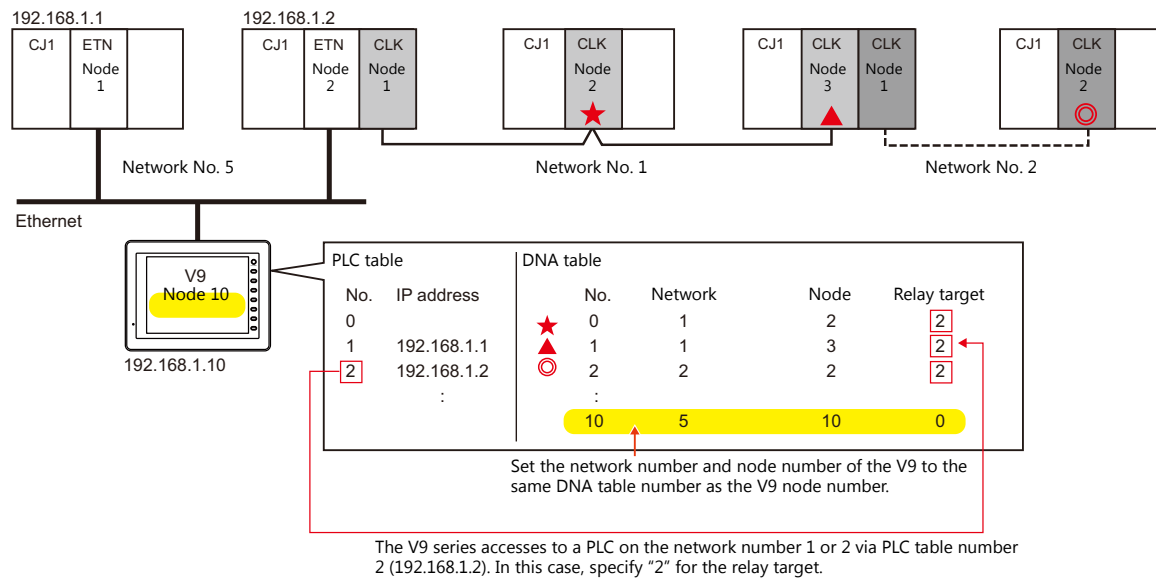

Communication Setting

Editor

Make the following settings on the editor. For more information, see "1.3.2 Ethernet Communication".

- IP address for the V9 unit
 - When specified on the screen program:
[System Setting] → [Hardware Setting] → [Local Port IP Address]
 - When specified on the V9 unit:
Local mode → [LAN Setting]
- Port number (for communication with PLC) and local port number (V9 DNA table number) of the V9 unit
[System Setting] → [Hardware Setting] → [PLC Properties] → [Communication Setting]

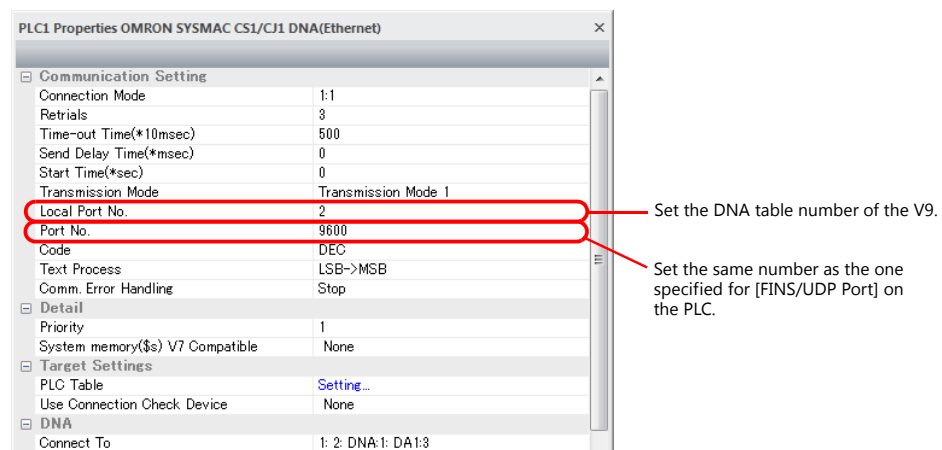

- IP address and port number of the PLC
Register on the [PLC Table] in [System Setting] → [Hardware Setting] → [PLC Properties] → [Target Settings].

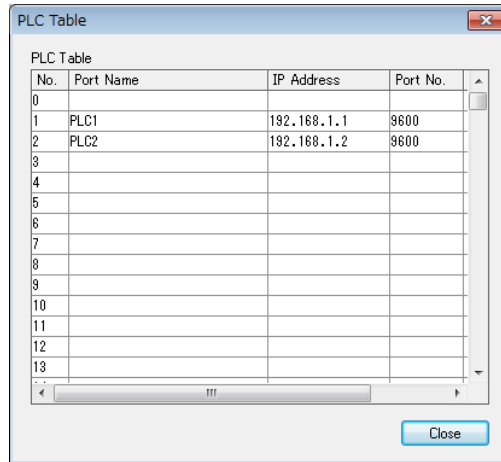

PLC table No. = PLC node address

Set the IP address, port number and whether or not to use the KeepAlive function to the same number as the PLC node address.

- Network number and node number of the PLC, PLC table number of the relay PLC
Network number and node number of the V9
[System Setting] → [Hardware Setting] → [PLC Properties] → [DNA]

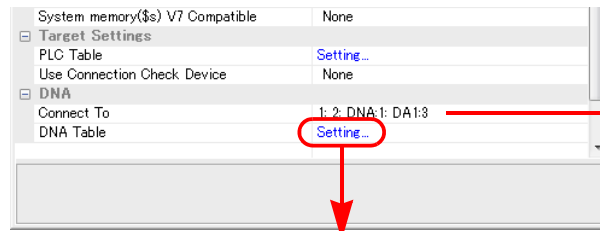

Valid only for 1 : 1 connection

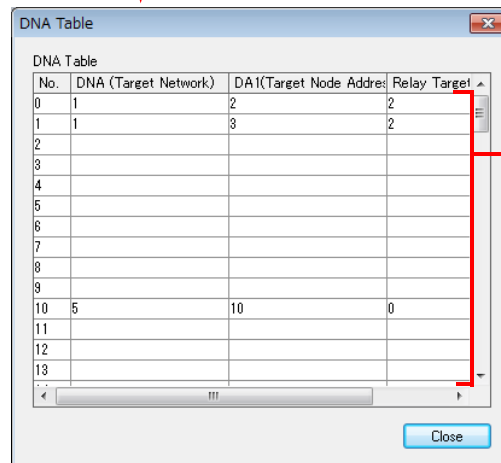

Set the network number and node number of the PLC, and the PLC table number of the relay PLC.

Set the network number and node number of the V9 to the same number as the one specified for [Local Port No.] on the V9. [Relay Target Network Table No.] is disabled.

PLC

Communication setting

Make the following settings on CX Programmer. For more information, refer to the PLC manual issued by the manufacturer.

Parameter setting

Item	Setting
IP Address	IP address of the PLC
Subnet Mask	Subnet mask of the PLC
IP Address Conversion	IP address table
IP Address Table	IP address and node number of the PLC IP address and node number of the V9
FINS/UDP Port	Default (9600)

Rotary switch

Switch	Setting
NODE No.	Set the node number of the Ethernet unit or Controller Link unit.

CX-Integrator

Set the PLC routing table on "CX-Integrator". Two types of routing tables are available: local network table and relay network table.

An error will occur unless these settings are made correctly. For more information, refer to the PLC manual issued by the manufacturer.

- Local network table
Set the unit number and network number of the communication unit.
- Relay network table
Set the network number of the access target (final network No.) and the first relay point (relay network No., relay node No.).

Available Device Memory

The available device memory is the same as the one described in "13.1.5 SYSMAC CS1/CJ1 (Ethernet)".

13.1.8 Wiring Diagrams

When Connected at CN1:

RS-232C

Wiring diagram 1 - C2

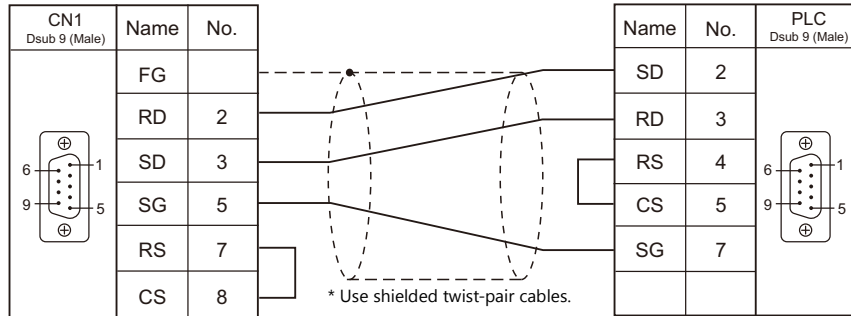

Wiring diagram 2 - C2

Hakko Electronics' cable "D9-OM2-09-□M" (□ = 2, 3, 5, 10, 15)

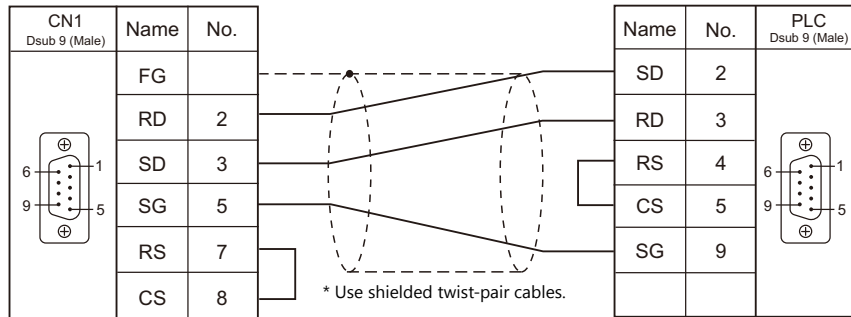

Wiring diagram 3 - C2

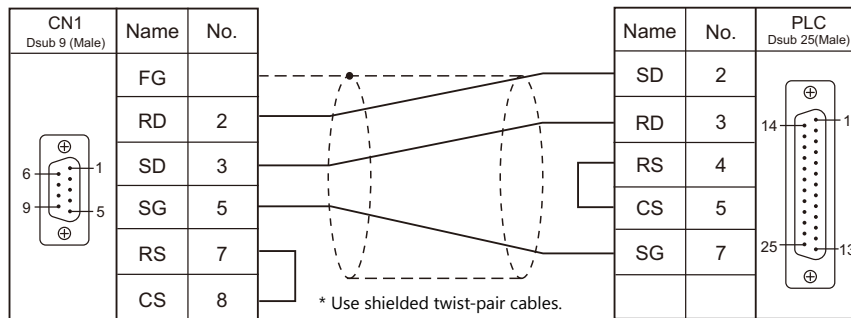

RS-422/RS-485

Wiring diagram 1 - C4

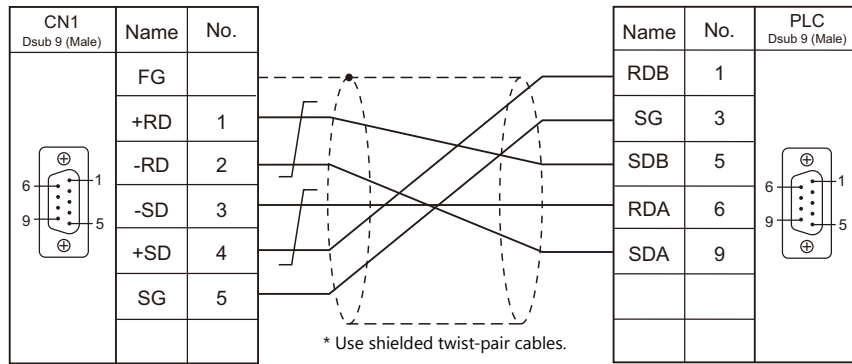

Wiring diagram 2 - C4

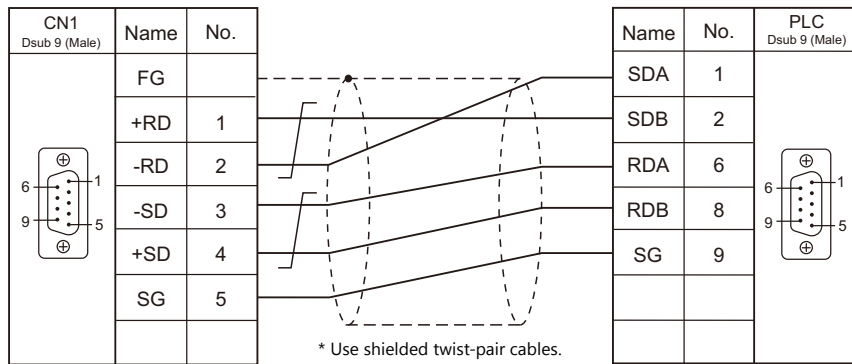

Wiring diagram 3 - C4

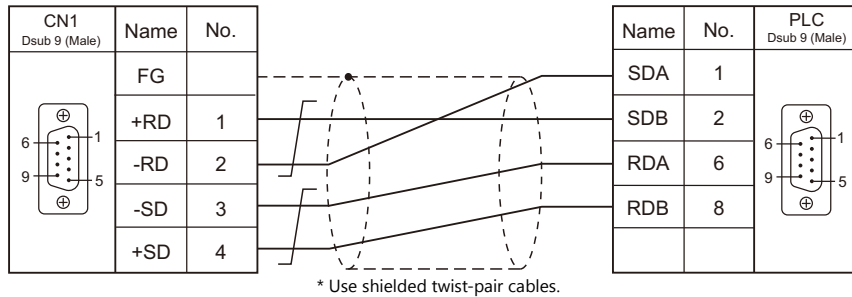

Wiring diagram 4 - C4

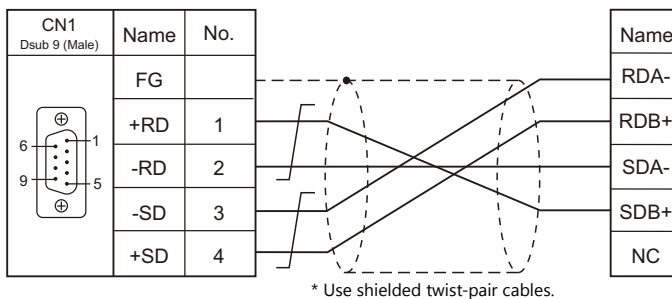

Wiring diagram 5 - C4

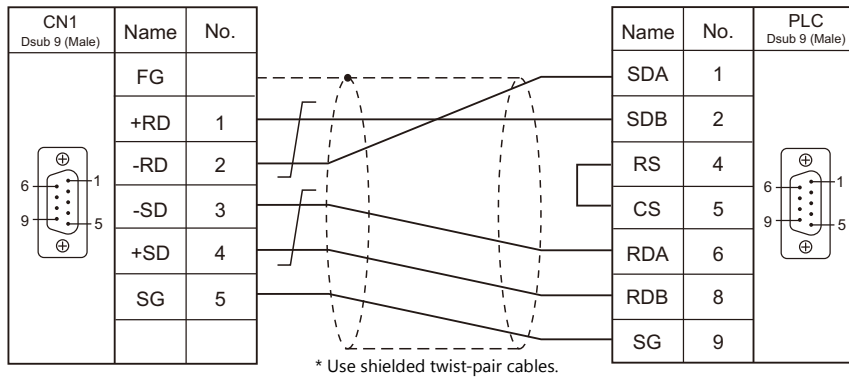

When Connected at MJ1/MJ2:

RS-232C

Wiring diagram 1 - M2

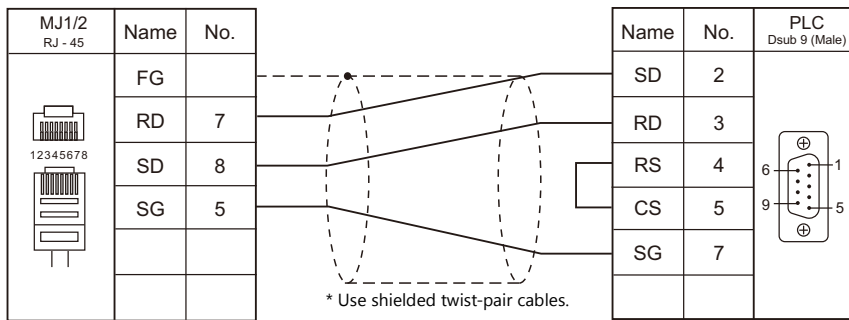

Wiring diagram 2 - M2

Hakko Electronics' cable "MJ-OM209-□ M" (□ = 2, 3, 5, 10, 15)

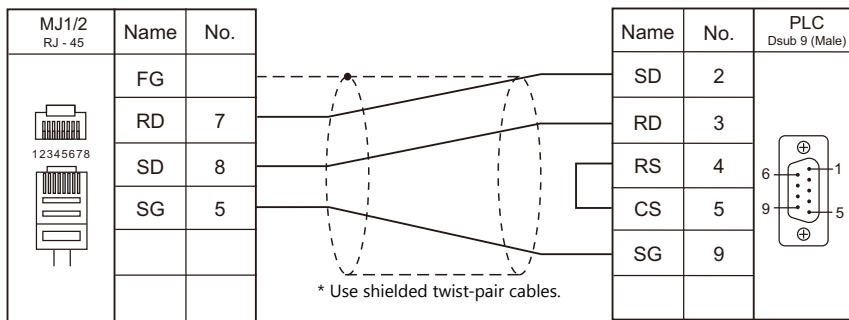

Wiring diagram 3 - M2

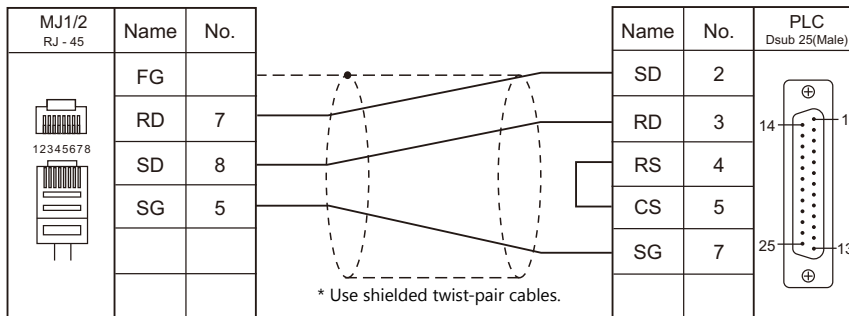

Wiring diagram 4 - M2

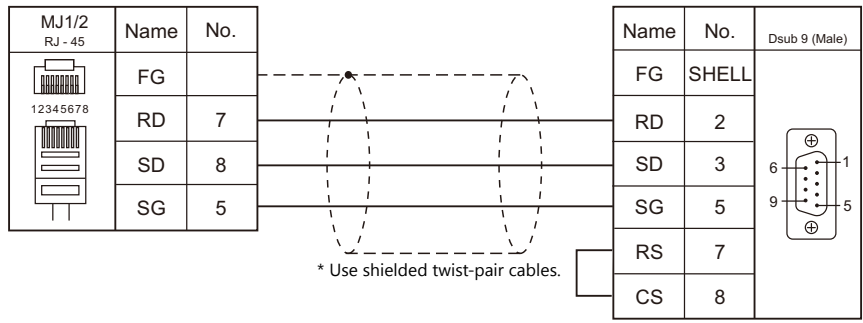

RS-422/RS-485

Wiring diagram 1 - M4

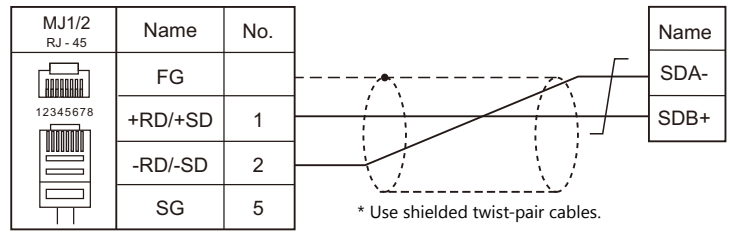

13.2 Temperature Controller/Servo/Inverter Connection

Temperature Controller

PLC Selection on the Editor	Model	Port	Signal Level	Connection		Lst File		
				CN1	MJ1/MJ2			
E5AK	E5AK-xxx01xx	Terminal	RS-232C	Wiring diagram 1 - C2	Wiring diagram 1 - M2	E5AK.Lst		
	E5AK-xxx02xx	Terminal	RS-422	Wiring diagram 2 - C4	×			
	E5AK-xxx03xx	Terminal	RS-485	Wiring diagram 3 - C4	Wiring diagram 2 - M4			
E5AK-T	E5AK-Txx01xx	Terminal	RS-232C	Wiring diagram 1 - C2	Wiring diagram 1 - M2	E5AKT.Lst		
	E5AK-Txx02xx	Terminal	RS-422	Wiring diagram 2 - C4	×			
	E5AK-Txx03xx	Terminal	RS-485	Wiring diagram 3 - C4	Wiring diagram 2 - M4			
E5AN/E5EN/E5CN/ E5GN	E5AN-xxxx01xxxxFLK E5EN-xxxx01xxxxFLK	Terminal	RS-232C	Wiring diagram 1 - C2	Wiring diagram 1 - M2	E5AN.Lst		
	E5CN-xxxx03xxxxFLK E5AN-xxxx03xxxxFLK E5EN-xxxx03xxxxFLK E5GN-xx03x-FLK	Terminal	RS-485	Wiring diagram 1 - C4	Wiring diagram 1 - M4			
	E5AR/E5ER	E5AR-xxxxxxxx-FLK E5ER-xxxxxxxx-FLK	Terminal	RS-485	Wiring diagram 1 - C4		Wiring diagram 1 - M4	E5AR.Lst
	E5CK	E5CK-xxx01	Terminal	RS-232C	Wiring diagram 1 - C2		Wiring diagram 1 - M2	E5CK.Lst
E5CK-xxx03		Terminal	RS-485	Wiring diagram 1 - C4	Wiring diagram 1 - M4			
E5CK-T	E5CK-Txx01	Terminal	RS-232C	Wiring diagram 1 - C2	Wiring diagram 1 - M2	E5CKT.Lst		
	E5CK-Txx03	Terminal	RS-485	Wiring diagram 1 - C4	Wiring diagram 1 - M4			
E5CN-HT	E5CN-HTxxx01xx-x-FLK E5AN-HTxxxx01Bxx-x-FLK E5EN-HTxxxx01Bxx-x-FLK	Terminal	RS-232C	Wiring diagram 1 - C2	Wiring diagram 1 - M2	E5CN-HT.Lst		
	E5AN-HTxxxx02Bxx-x-FLK E5EN-HTxxxx02Bxx-x-FLK	Terminal	RS-422	Wiring diagram 2 - C4	×			
	E5CN-HTxxx03xx-x-FLK E5AN-HTxxxx03Bxx-x-FLK E5EN-HTxxxx03Bxx-x-FLK	Terminal	RS-485	Wiring diagram 1 - C4	Wiring diagram 1 - M4			
	E5EK	E5EK-xxx01xx	Terminal	RS-232C	Wiring diagram 1 - C2		Wiring diagram 1 - M2	E5EK.Lst
E5EK-xxx02xx		Terminal	RS-422	Wiring diagram 2 - C4	×			
E5EK-xxx03xx		Terminal	RS-485	Wiring diagram 3 - C4	Wiring diagram 2 - M4			
E5ZD	E5ZD-4xx01xx E5ZD-6xx01xx	CN4	RS-232C	Wiring diagram 2 - C2	Wiring diagram 2 - M2	E5ZD.Lst		
	E5ZD-8xx01xx	CN501						
	E5ZD-4xx02xx E5ZD-6xx02xx	CN6	RS-422	Wiring diagram 4 - C4	×			
	E5ZD-8xx02xx	CN502						
		TB302						
	E5ZD-4xx03xx E5ZD-6xx03xx	CN6	RS-485	Wiring diagram 5 - C4	Wiring diagram 3 - M4			
	E5ZD-8xx03xx	CN502						
	TB302							
E5ZE	E5ZE-8xxx01xx	-	RS-232C	Wiring diagram 2 - C2	Wiring diagram 2 - M2	E5ZE.Lst		
	E5ZE-8xxx04xx	Terminal	RS-422/485	Wiring diagram 2 - C4	Wiring diagram 4 - M4			
E5ZN	E5ZN	Terminal	RS-485	Wiring diagram 1 - C4	Wiring diagram 1 - M4	E5ZN.Lst		

ID Controller

PLC Selection on the Editor	Model	Port	Signal Level	Connection		Lst File
				CN1	MJ1/MJ2	
V600/620/680	V600-CA1A-V	Dsub25	RS-232C	Wiring diagram 2 - C2	Wiring diagram 2 - M2	OM_V600.Lst
	V600-CA2A-V	Dsub9	RS-422	Wiring diagram 4 - C4	Wiring diagram 5 - M4	
	V600-CD1D	Dsub9	RS-232C	Wiring diagram 3 - C2	Wiring diagram 3 - M2	
	V680-CA5D01-V2 V680-CA5D02-V2	Dsub9	RS-232C			
		Terminal	RS-485	Wiring diagram 2 - C4	Wiring diagram 2 - M4	

Power Meter

PLC Selection on the Editor	Model	Port	Signal Level	Connection		Lst File
				CN1	MJ1/MJ2	
KM20	KM20-B40-FLK	Terminal	RS-485	Wiring diagram 1 - C4	Wiring diagram 1 - M4	OM_KM20.Lst
		K3SC terminal	RS-232C	Wiring diagram 4 - C2	Wiring diagram 4 - M2	
KM100	KM100-Tx-FLK	Terminal	RS-485	Wiring diagram 1 - C4	Wiring diagram 1 - M4	OM_KM100.Lst
		K3SC terminal	RS-232C	Wiring diagram 4 - C2	Wiring diagram 4 - M2	

13.2.1 E5AK

Communication Setting

Editor

Communication setting

(Underlined setting: default)

Item	Setting	Remarks
Connection Mode	1 : 1 / <u>1 : n</u> / Multi-link2 / Multi-link2 (Ethernet) / 1 : n Multi-link2 (Ethernet)	
Signal Level	RS-232C / <u>RS-422/485</u>	
Baud Rate	4800 / <u>9600</u> / 19200 bps	
Data Length	<u>7</u> / 8 bits	
Stop Bit	1 / <u>2</u> bits	
Parity	None / Odd / <u>Even</u>	
Target Port No.	<u>0</u> to 31	

Temperature Controller

(Underlined setting: default)

Mode	Displayed Character	Setting Data	Setting
Option mode	Sbit	Stop bit	1 / <u>2</u> bits
	LEn	Data length	<u>7</u> / 8 bits
	Prty	Parity	None / Odd / <u>Even</u>
	bPS	Baud rate	4800 / <u>9600</u> / 19200 bps
	U-no	Communication unit No.	<u>0</u> to 31

Available Device Memory

The available setting range of device memory varies depending on the model. Be sure to set within the range available for the model to be used. Use [TYPE] when assigning indirect device memory for macro programs.

Device Memory	TYPE	Remarks
D (parameter)	00H	
S (special command)	01H	S00 to 11 Write only, expansion code: fixed to 0
		S14 Read only, expansion code 0: group A / 1: group B

Indirect Device Memory Designation

	15	8 7	0
n + 0	Model (91 to 98)		Device type
n + 1	Address No.		
n + 2	Expansion code		Bit designation
n + 3	00		Station number

When monitoring special command S14 (status), specify the group number in the expansion code.

00H: Group A

01H: Group B

13.2.2 E5AK-T

Communication Setting

Editor

Communication setting

(Underlined setting: default)

Item	Setting	Remarks
Connection Mode	1 : 1 / <u>1:n</u> / Multi-link2 / Multi-link2 (Ethernet) / 1 : n Multi-link2 (Ethernet)	
Signal Level	RS-232C / <u>RS-422/485</u>	
Baud Rate	4800 / <u>9600</u> / 19200 bps	
Data Length	<u>Z</u> / 8 bits	
Stop Bit	1 / <u>2</u> bits	
Parity	None / Odd / <u>Even</u>	
Target Port No.	<u>Q</u> to 99	

Temperature Controller

(Underlined setting: default)

Mode	Displayed Character	Setting Data	Setting
Option mode	Sbit	Stop bit	1 / <u>2</u> bits
	LEn	Data length	<u>Z</u> / 8 bits
	Prty	Parity	None / Odd / <u>Even</u>
	bPS	Baud rate	4800 / <u>9600</u> / 19200 bps
	U-no	Communication unit No.	<u>Q</u> to 99

Available Device Memory

The available setting range of device memory varies depending on the model. Be sure to set within the range available for the model to be used. Use [TYPE] when assigning indirect device memory for macro programs.

Device Memory	TYPE	Remarks
D (parameter)	00H	
S (special command)	01H	S00 to 11 Write only, expansion code: fixed to 0
		S14 Read only, expansion code 0: group A / 1: group B
P (program parameter)	02H	

Indirect Device Memory Designation

	15	8 7	0
n+0	Model (91 to 98)		Device type
n+1	Address No.		
n+2	Expansion code		Bit designation
n+3	00		Station number

When monitoring special command S14 (status), specify the group number in the expansion code.

00H: Group A

01H: Group B

13.2.3 E5AN/E5EN/E5CN/E5GN

Communication Setting

Editor

Communication setting

(Underlined setting: default)

Item	Setting	Remarks
Connection Mode	1 : 1 / <u>1 : n</u> / Multi-link2 / Multi-link2 (Ethernet) / 1 : n Multi-link2 (Ethernet)	
Signal Level	RS-232C / <u>RS-422/485</u>	
Baud Rate	4800 / <u>9600</u> / 19200 / 38400 / 57600 bps	
Data Length	<u>7</u> / 8 bits	
Stop Bit	1 / <u>2</u> bits	
Parity	None / Odd / <u>Even</u>	
Target Port No.	0 to 31	

Temperature Controller

E5CN/E5SAN/E5EN

Communication level setting

(Underlined setting: default)

Level	Displayed Character	Setting Data	Setting
Communication level	PSEL	Protocol selection	CompoWay/F
	U-no	Communication unit No.	0 to 31
	bps	Baud rate	4800 / <u>9600</u> / 19200 / 38400 / 57600 bps
	LEn	Data length	<u>7</u> / 8 bits
	Sbit	Communication stop bit	1 / <u>2</u> bits
	Prty	Parity	None / Odd / <u>Even</u>
Adjustment level	CMWT	Communication writing ^{*1}	OFF / ON

*1 When writing setting data from the V9, set "ON" for the "communication writing" setting.

E5GN

Communication level setting

(Underlined setting: default)

Level	Displayed Character	Setting Data	Setting
Communication level	U-no	Communication unit No.	0 to 31
	bps	Baud rate	4800 / 9600 / 19200 bps
	LEn	Data length	<u>7</u> / 8 bits
	Sbit	Communication stop bit	1 / <u>2</u> bits
	Prty	Parity	None / Odd / <u>Even</u>
Adjustment level	CMWT	Communication writing ^{*1}	OFF / ON

*1 When writing setting data from the V9, set "ON" for the "communication writing" setting.

Available Device Memory

The available setting range of device memory varies depending on the model. Be sure to set within the range available for the model to be used. Use [TYPE] when assigning indirect device memory for macro programs.

Device Memory	TYPE	Remarks
C0 (setting area 0)	00H	Double-word, read only
C1 (setting area 0)	01H	Double-word
C3 (setting area 1)	03H	Double-word

Indirect Device Memory Designation

	15	8 7	0
n + 0	Model (91 to 98)	Device type	
n + 1	Address No.		
n + 2	Expansion code	Bit designation	
n + 3	00	Station number	

For bit designation, an expansion code setting is required.

- 00H: when designating bit 0 to 15
- 01H: when designating bit 16 to 31

PLC_CTL

Macro command "PLC_CTL F0 F1 F2"

Contents	F0	F1 (= \$u n)	F2										
Read controller status	1 - 8 (PLC1 - 8)	n	Station number										
		n + 1	Command: 0006H										
		n + 2	Operation status (higher byte) 00: Control in execution (Operation in progress while the setting area is "0" with no error occurring) 01: Control not in execution (Other than above) Related information (lower byte) <div style="display: flex; align-items: center;"> <div style="margin-right: 10px;">Bit</div> <table border="1" style="border-collapse: collapse; text-align: center;"> <tr> <td style="width: 15px;">-</td> <td style="width: 15px;">7</td> <td style="width: 15px;">6</td> <td style="width: 15px;">5</td> <td style="width: 15px;">4</td> <td style="width: 15px;">3</td> <td style="width: 15px;">2</td> <td style="width: 15px;">1</td> <td style="width: 15px;">0</td> </tr> </table> </div> <div style="margin-left: 100px; margin-top: 5px;"> Input error ———— Beyond the display range ———— ———— Heater overcurrent (CT1) ———— Heater current hold (CT1) ———— A/D converter error ———— Heater overcurrent (CT2) ———— Heater current hold (CT2) </div>	-	7	6	5	4	3	2	1	0	2
-	7	6	5	4	3	2	1	0					
Operation instructions	1 - 8 (PLC1 - 8)	n	Station number*1										
		n + 1	Command: 0030H										
		n + 2	Communication writing 0000H: Communication writing OFF (disabled) 0001H: Communication writing ON (enabled)										
			Control start/stop 0100H: Channel 1 Run 0101H: Channel 1 Stop										
			Multi-SP 0200H: Target value 1 0201H: Target value 2 0202H: Target value 3 0203H: Target value 4										
			AT execution/cancel 0300H: Cancel 0301H: Execute										
			Write mode 0400H: Backup mode 0401H: RAM write mode										
			0500H: Save RAM data										
			0600H: Software reset										
			0700H: Move to set area 1										
0800H: Move to protect level													

*1 8000 (HEX): broadcasting

Return data: Data stored from temperature controller to V series

13.2.4 E5AR/E5ER

Communication Setting

Editor

Communication setting

(Underlined setting: default)

Item	Setting	Remarks
Connection Mode	1 : 1 / <u>1 : n</u> / Multi-link2 / Multi-link2 (Ethernet) / 1 : n Multi-link2 (Ethernet)	
Signal Level	RS-422/485	
Baud Rate	<u>9600</u> / 19200 / 38400 bps	
Data Length	<u>7</u> / 8 bits	
Stop Bit	1 / <u>2</u> bits	
Parity	None / Odd / <u>Even</u>	
Target Port No.	<u>0</u> to 31	

Temperature Controller

Communication level setting (LS)

(Underlined setting: default)

Level	Displayed Character	Setting Data	Setting
Communication level (L.S)	PSEL	Protocol selection	CompoWay/F
	U-no	Communication unit No.	0 to 31
	bps	Baud rate	<u>9600</u> / 19200 / 38400 bps
	LEn	Communication data length	<u>7</u> / 8 bits
	Sbit	Communication stop bit	1 / <u>2</u> bits
	Prty	Communication parity	None / Odd / <u>Even</u>
Adjustment level (L.Adj)	CMWT	Communication writing ^{*1}	OFF / ON

*1 When writing setting data from the V9, set "ON" for the "communication writing" setting.

Available Device Memory

The available setting range of device memory varies depending on the model. Be sure to set within the range available for the model to be used. Use [TYPE] when assigning indirect device memory for macro programs.

Device Memory	TYPE	Remarks
C0 (communication monitor)	00H	Double-word
C1 (communication monitor)	01H	Double-word
C4 (communication monitor)	03H	Double-word
C5 (protection level)	04H	Double-word
C6 (run level)	05H	Double-word
C7 (adjustment level)	06H	Double-word
C8 (adjustment 2 level)	07H	Double-word
C9 (bank setting level)	08H	Double-word
CA (PID setting level)	09H	Double-word
CB (approximation setting level)	0AH	Double-word
CC (default setting level for input)	0BH	Double-word
CD (default setting level for control)	0CH	Double-word
CE (default setting level 2 for control)	0DH	Double-word
CF (warning setting level)	0EH	Double-word
D0 (display adjustment level)	0FH	Double-word
D1 (communication level)	10H	Double-word
D2 (high-performance setting level)	11H	Double-word
D3 (extended control setting level)	12H	Double-word

Indirect Device Memory Designation

	15	8 7	0
n + 0	Model (91 to 98)	Device type	
n + 1	Address No.		
n + 2	Expansion code	Bit designation	
n + 3	00	Station number	

For bit designation, an expansion code setting is required.
 00H: when designating bit 0 to 15
 01H: when designating bit 16 to 31

PLC_CTL

Macro command "PLC_CTL F0 F1 F2"

Contents	F0	F1 (= \$u n)	F2								
Read controller status	1 - 8 (PLC1 - 8)	n	Station number								
		n + 1	Command: 0006H								
		n + 2	Status <table border="1" style="margin-top: 10px;"> <thead> <tr> <th>Bit</th> <th>Operation status</th> </tr> </thead> <tbody> <tr> <td>00</td> <td>Control in progress</td> </tr> <tr> <td>01</td> <td>Error occurring (outputting manipulated variables at an occurrence of error)</td> </tr> <tr> <td>10</td> <td>Resetting (including setting area 1)</td> </tr> <tr> <td>11</td> <td>Manual mode</td> </tr> </tbody> </table>	Bit	Operation status	00	Control in progress	01	Error occurring (outputting manipulated variables at an occurrence of error)	10	Resetting (including setting area 1)
Bit	Operation status										
00	Control in progress										
01	Error occurring (outputting manipulated variables at an occurrence of error)										
10	Resetting (including setting area 1)										
11	Manual mode										
n + 3	Relevant information 										
Operation instructions	1 - 8 (PLC1 - 8)	n	Station number *1								
		n + 1	Command: 0030H								
		n + 2	Communication writing 0000H: Communication writing OFF (disabled) 0001H: Communication writing ON (enabled) Control start/stop 0100H: Channel 1 RUN 0101H: Channel 1 STOP 0110H: Channel 2 RUN 0111H: Channel 2 STOP 0120H: Channel 3 RUN 0121H: Channel 3 STOP 0130H: Channel 4 RUN 0131H: Channel 4 STOP 01F0H: All channels Run 01F1H: All channels Stop Bank selection 0200 to 0207H: Channel 1 Bank Nos. 0 to 7 0210 to 0217H: Channel 2 Bank Nos. 0 to 7 0220 to 0227H: Channel 3 Bank Nos. 0 to 7 0230 to 0237H: Channel 4 Bank Nos. 0 to 7 02F0 to 02F7H: All channels Bank Nos. 0 to 7 AT execution 0300H: Channel 1 PID group number currently selected 0301 to 0308H: Channel 1 PID group Nos. 1 to 8 designation 0310H: Channel 2 PID group number currently selected 0311 to 0318H: Channel 2 PID group Nos. 1 to 8 designation 0320H: Channel 3 PID group number currently selected 0321 to 0328H: Channel 3 PID group Nos. 1 to 8 designation 0330H: Channel 4 PID group number currently selected 0331 to 0338H: Channel 4 PID group Nos. 1 to 8 designation 03F0H: All channels PID group number currently selected 03F1 to 03F8H: All channels PID group Nos. 1 to 8 designation								

Contents	F0	F1 (= \$u n)		F2
Operation instructions	1 - 8 (PLC1 - 8)	n + 2	AT cancellation 0A00H: Channel 1 0A10H: Channel 2 0A20H: Channel 3 0A30H: Channel 4 09F0H: All channels Write mode 0400H: Backup mode 0401H: RAM write mode 0500H: Save RAM data 0600H: Software reset 0700H: Move to set area 1 0800H: Move to protect level Auto/manual 0900H: Channel 1 Auto mode 0901H: Channel 1 Manual mode 0910H: Channel 2 Auto mode 0911H: Channel 2 Manual mode 0920H: Channel 3 Auto mode 0921H: Channel 3 Manual mode 0930H: Channel 4 Auto mode 0931H: Channel 4 Manual mode 09F0H: All channels Auto mode 09F1H: All channels Manual mode 0B00H: Initialize Unlatch 0C00H: Channel 1 Warning unlatch 0C10H: Channel 2 Warning unlatch 0C20H: Channel 3 Warning unlatch 0C30H: Channel 4 Warning unlatch 0CF0H: All channels Warning unlatch SP mode 0D00H: Channel 1 Local SP 0D01H: Channel 1 Remote SP 0D10H: Channel 2 Local SP (Cascade open) 0D11H: Channel 2 Remote SP (Cascade close)	3

*1 8000 (HEX): broadcasting

Return data: Data stored from temperature controller to V series

13.2.5 E5CK

Communication Setting

Editor

Communication setting

(Underlined setting: default)

Item	Setting	Remarks
Connection Mode	1 : 1 / <u>1:n</u> / Multi-link2 / Multi-link2 (Ethernet) / 1 : n Multi-link2 (Ethernet)	
Signal Level	RS-232C / <u>RS-422/485</u>	
Baud Rate	4800 / <u>9600</u> / 19200 bps	
Data Length	<u>7</u> / 8 bits	
Stop Bit	1 / <u>2</u> bits	
Parity	None / Odd / <u>Even</u>	
Target Port No.	<u>0</u> to 31	

Temperature Controller

(Underlined setting: default)

Mode	Displayed Character	Setting Data	Setting
Option mode	Sbit	Stop bit	1 / <u>2</u> bits
	LEn	Data length	<u>7</u> / 8 bits
	Prty	Parity	None / Odd / <u>Even</u>
	bPS	Baud rate	4800 / <u>9600</u> / 19200 bps
	U-no	Communication unit No.	<u>0</u> to 31

Available Device Memory

The available setting range of device memory varies depending on the model. Be sure to set within the range available for the model to be used. Use [TYPE] when assigning indirect device memory for macro programs.

Device Memory	TYPE	Remarks
D (parameter)	00H	
S (special command)	01H	Write only, expansion code: fixed to 0

13.2.6 E5CK-T

Communication Setting

Editor

Communication setting

(Underlined setting: default)

Item	Setting	Remarks
Connection Mode	1 : 1 / <u>1:n</u> / Multi-link2 / Multi-link2 (Ethernet) / 1 : n Multi-link2 (Ethernet)	
Signal Level	RS-232C / <u>RS-422/485</u>	
Baud Rate	4800 / <u>9600</u> / 19200 bps	
Data Length	<u>7</u> / 8 bits	
Stop Bit	1 / <u>2</u> bits	
Parity	None / Odd / <u>Even</u>	
Station number	<u>0</u> to 99	

Temperature Controller

(Underlined setting: default)

Mode	Displayed Character	Setting Data	Setting
Option mode	Sbit	Stop bit	1 / <u>2</u> bits
	LEn	Data length	<u>7</u> / 8 bits
	Prty	Parity	None / Odd / <u>Even</u>
	bPS	Baud Rate	4800 / <u>9600</u> / 19200 bps
	U-no	Communication unit No.	<u>0</u> to 99

Available Device Memory

The available setting range of device memory varies depending on the model. Be sure to set within the range available for the model to be used. Use [TYPE] when assigning indirect device memory for macro programs.

Device Memory	TYPE	Remarks
D (parameter)	00H	
S (special command)	01H	S00 to 11 Write only, expansion code: fixed to 0 S14 Read only, expansion code 0: group A / 1: group B
P (program parameter)	02H	

Indirect Device Memory Designation

	15	8 7	0
n+0	Model (91 to 98)		Device type
n+1	Address No.		
n+2	Expansion code		Bit designation
n+3	00		Station number

When monitoring special command S14 (status), specify the group number in the expansion code.

00H: Group A

01H: Group B

13.2.7 E5CN-HT

Communication Setting

Editor

Communication setting

(Underlined setting: default)

Item	Setting	Remarks
Connection Mode	1 : 1 / <u>1 : n</u> / Multi-link2 / Multi-link2 (Ethernet) 1 : n Multi-link2 (Ethernet)	
Signal Level	RS-232C / <u>RS-422/485</u>	
Baud Rate	4800 / <u>9600</u> / 19200 / 38400 / 57600 bps	
Data Length	<u>7</u> / 8 bits	
Stop Bit	1 / <u>2</u> bits	
Parity	None / Odd / <u>Even</u>	
Target Port No.	0 to 31	

Temperature Controller

E5CN-HT/E5AN-HT/E5EN-HT

Communication level setting

(Underlined setting: default)

Level	Displayed Character	Setting Data	Setting
Communication level	PSEL	Communication protocol	CompoWay/F
	U-no	Communication unit No.	0 to 31
	bps	Baud rate	4800 / <u>9600</u> / 19200 / 38400 / 57600 bps
	LEn	Data length	<u>7</u> / 8 bits
	Sbit	Stop bit	1 / <u>2</u> bits
	Prty	Parity	None / Odd / <u>Even</u>
Adjustment level	CMWT	Communication writing ^{*1}	OFF / ON

*1 When writing the setting data from the V9, set "ON" for the "communication writing" setting.

Available Device Memory

The available setting range of device memory varies depending on the model. Be sure to set within the range available for the model to be used. Use [TYPE] when assigning indirect device memory for macro programs.

Device Memory	TYPE	Remarks
C0 (setting area 0)	00H	Double-word, read only
C1 (setting area 0)	01H	Double-word
C3 (setting area 1)	02H	Double-word
C4 (setting area 0)	03H	Double-word
C5 (setting area 0)	04H	Double-word
DA (setting area 0)	05H	Double-word

Indirect Device Memory Designation

	15	8 7	0
n + 0	Model (91 to 98)	Device type	
n + 1	Address No.		
n + 2	Expansion code	Bit designation	
n + 3	00	Station number	

For bit designation, an expansion code setting is required.

00H: when designating bit 0 to 15

01H: when designating bit 16 to 31

PLC_CTL

Macro command "PLC_CTL F0 F1 F2"

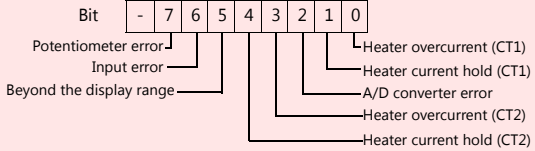
Contents	F0	F1 (= \$u n)		F2
Read controller status	1 - 8 (PLC1 - 8)	n	Station number	2
		n + 1	Command: 0006H	
		n + 2	Operation status (higher byte) 00: Control not in execution (Setting area 1, outputting manipulated variables for manual operation, resetting operation or alarm occurrence) 01: Control in execution (Other than above) Related information (lower byte) 	
Operation instructions	1 - 8 (PLC1 - 8)	n	Station number *1	3
		n + 1	Command: 0030H	
		n + 2	Communication writing 0000H: Communication writing OFF (disabled) 0001H: Communication writing ON (enabled)	
			Control start/stop 0100H: Channel 1 RUN 0101H: Channel 1 STOP	
			AT execution/cancel 0300H: AT cancel 0301H: AT execution at 100% 0302H: AT execution at 40%	
			Write mode 0400H: Backup mode 0401H: RAM write mode	
			0500H: Save RAM data	
			0600H: Software reset	
			0700H: Shift to set area 1	
			0800H: Protection level shift	
			Auto/manual 0900H: Auto mode 0901H: Manual mode	
			0B00H: Initialize	
			Alarm latch cancel 0C00H: Alarm latch 1 cancel 0C01H: Alarm latch 2 cancel 0C02H: Alarm latch 3 cancel 0C03H: Heater disconnection latch cancel 0C04H: SSR failure latch cancel 0C05H: Heater overcurrent latch cancel 0C0FH: All latch cancel	
			SP mode 0D00H: Program SP mode 0D01H: Remote SP mode 0D02H: Constant value control SP mode	
			Invert direct/reverse operation 0E00H: Not invert 0E01H: Invert	
			Infrared communication 1200H: OFF 1201H: ON	
Hold 1300H: Hold cancel 1301H: Hold				
1400H: Advance				
Readout of main unit's attribute	1 - 8 (PLC1 - 8)	n	Station number	2
		n + 1	Command: 0005H	
		n + 2 - n + 6	Type (CHAR) * Data following 11th byte or later is discarded.	
		n + 8	Buffer size (HEX)	

*1 8000 (HEX): broadcasting

Response code: Data stored from temperature controller to V series

13.2.8 E5EK

Communication Setting

Editor

Communication setting

(Underlined setting: default)

Item	Setting	Remarks
Connection Mode	1 : 1 / <u>1:n</u> / Multi-link2 / Multi-link2 (Ethernet) / 1 : n Multi-link2 (Ethernet)	
Signal Level	RS-232C / <u>RS-422/485</u>	
Baud Rate	4800 / <u>9600</u> / 19200 bps	
Data Length	<u>7</u> / 8 bits	
Stop Bit	1 / <u>2</u> bits	
Parity	None / Odd / <u>Even</u>	
Target Port No.	<u>0</u> to 31	

Temperature Controller

(Underlined setting: default)

Mode	Displayed Character	Setting Data	Setting
Option mode	Sbit	Stop bit	1 / <u>2</u> bits
	LEn	Data length	<u>7</u> / 8 bits
	Prty	Parity	None / Odd / <u>Even</u>
	bPS	Baud rate	4800 / <u>9600</u> / 19200 bps
	U-no	Communication unit No.	<u>0</u> to 31

Available Device Memory

The available setting range of device memory varies depending on the model. Be sure to set within the range available for the model to be used. Use [TYPE] when assigning indirect device memory for macro programs.

Device Memory	TYPE	Remarks
D (parameter)	00H	
S (special command)	01H	S00 to 11 Write only, expansion code: fixed to 0
		S14 Read only, expansion code 0: group A / 1: group B

Indirect Device Memory Designation

	15	8 7	0
n + 0	Model (91 to 98)		Device type
n + 1	Address No.		
n + 2	Expansion code		Bit designation
n + 3	00		Station number

When monitoring special command S14 (status), specify the group number in the expansion code.

00H: Group A

01H: Group B

13.2.9 E5ZD

Communication Setting

Editor

Communication setting

(Underlined setting: default)

Item	Setting	Remarks
Connection Mode	1 : 1 / <u>1 : n</u> / Multi-link2 / Multi-link2 (Ethernet) / 1 : n Multi-link2 (Ethernet)	
Signal Level	RS-232C / <u>RS-422/485</u>	
Baud Rate	4800 / <u>9600</u> bps	
Data Length	<u>7</u> bits	
Stop Bit	<u>2</u> bits	
Parity	<u>Even</u>	
Target Port No.	<u>0</u> to 15	

Temperature Controller

(Underlined setting: default)

Switch	Setting Data	Setting
SW2	Unit No.	<u>0</u> to F (= 0 to 15)
SW3	Baud rate	5: 4800 bps 6: 9600 bps

The following settings are fixed; data length: 7, stop bit: 2, and parity: even.

Available Device Memory

The available setting range of device memory varies depending on the model. Be sure to set within the range available for the model to be used. Use [TYPE] when assigning indirect device memory for macro programs.

Device Memory	TYPE	Remarks
0000 Control temperature	00H	
0001 Measurement temperature		Bank No. 0
0002 Operation status		Bank No. 0
0003 Output value		Bank No. 0
0004 Output value on the cooling side		Bank No. 0
0005 Proportional band		
0006 Integral time		
0007 Derivative time		
0008 Control cycle		
0009 Control cycle on the cooling side		
000A Output operation		Bank No. 0
000B Heater disconnection effective channel		Bank No. 0
000C Alarm status		Bank No. 0
000D Warning mode: warning 1		Bank No. 0
000E Warning mode: warning 2		Bank No. 0
000F Temperature at which an alarm occurs: warning 1		
0010 Temperature at which an alarm occurs: warning 2		
0011 Execution memory bank No.		Bank No. 0
0012 Adjustment sensitivity		
0013 Adjustment sensitivity on the cooling side		
0015 Input offset value		
001D Heater disconnection detection level		
001F Heater current value	Bank No. 0	
0021 Deadband / overlap band	Bank No. 0	
0022 Cooling coefficient		

Device Memory		TYPE	Remarks
-	0023 Fuzzy strength	00H	
	0024 Fuzzy scale 1		
	0025 Fuzzy scale 2		

Address denotations: Example: xx : yyyzzz

Channel number 0 to 7
 Address number
 Colon
 Bank number 0 to 7

Indirect Device Memory Designation

	15	8 7	0
n + 0	Model (91 to 98)	Device type	
n + 1	Address No. (lower)	CH No.	
n + 2	00	Address No. (higher)	
n + 3	Bank No.	Bit designation	
n + 4	00	Station number	

PLC_CTL

Macro command "PLC_CTL F0 F1 F2"

Contents	F0	F1 (= \$u n)		F2
Auto tuning	1 - 8 (PLC1 - 8)	n	Station number	3
		n + 1	Command: 0	
		n + 2	0 - 7: AT start channel No. 12: Cancel	
Setting data	1 - 8 (PLC1 - 8)	n	Station number	3
		n + 1	Command: 3	
		n + 2	0: Save 1: Initialize	
Operation control	1 - 8 (PLC1 - 8)	n	Station number	4
		n + 1	Command: 4	
		n + 2	0: Control start 1: Control stop	
		n + 3	Channel No.	

Return data: Data stored from temperature controller to V series

13.2.10 E5ZE

Communication Setting

Editor

Communication setting

(Underlined setting: default)

Item	Setting	Remarks
Connection Mode	1 : 1 / <u>1 : n</u> / Multi-link2 / Multi-link2 (Ethernet) / 1 : n Multi-link2 (Ethernet)	
Signal Level	RS-232C / <u>RS-422/485</u>	
Baud Rate	4800 / <u>9600</u> / 19200 bps	
Data Length	<u>7</u> bits	
Stop Bit	<u>2</u> bits	
Parity	<u>Even</u>	
Target Port No.	<u>Q</u> to 15	

Temperature Controller

Unit No.

(Underlined setting: default)

UNIT	Setting Items	Setting
	Unit No.	<u>Q</u> to F (= 0 to 15)

Function

(Underlined setting: default)

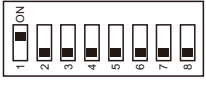
FUNCTION	Setting Items	Setting												
 SW1 SW2	Baud rate	<table border="1"> <thead> <tr> <th></th> <th>4800</th> <th><u>9600</u></th> <th>19200</th> </tr> </thead> <tbody> <tr> <td>SW1</td> <td>OFF</td> <td>ON</td> <td>OFF</td> </tr> <tr> <td>SW2</td> <td>ON</td> <td>OFF</td> <td>OFF</td> </tr> </tbody> </table>		4800	<u>9600</u>	19200	SW1	OFF	ON	OFF	SW2	ON	OFF	OFF
	4800	<u>9600</u>	19200											
SW1	OFF	ON	OFF											
SW2	ON	OFF	OFF											

Specification setting (RS-422/485)

FUNCTION	Setting Items	Setting											
 SW1 SW2 SW3 SW4	Interface	<table border="1"> <thead> <tr> <th></th> <th>RS-422</th> <th>RS-485</th> </tr> </thead> <tbody> <tr> <td>SW1</td> <td>OFF</td> <td>ON</td> </tr> <tr> <td>SW2</td> <td>OFF</td> <td>ON</td> </tr> </tbody> </table>		RS-422	RS-485	SW1	OFF	ON	SW2	OFF	ON		
		RS-422	RS-485										
SW1	OFF	ON											
SW2	OFF	ON											
Terminating resistance	<table border="1"> <thead> <tr> <th></th> <th>Provided (RS-422)</th> <th>Provided (RS-485)</th> <th>None</th> </tr> </thead> <tbody> <tr> <td>SW3</td> <td>ON</td> <td>ON</td> <td>OFF</td> </tr> <tr> <td>SW4</td> <td>ON</td> <td>OFF</td> <td>OFF</td> </tr> </tbody> </table>		Provided (RS-422)	Provided (RS-485)	None	SW3	ON	ON	OFF	SW4	ON	OFF	OFF
	Provided (RS-422)	Provided (RS-485)	None										
SW3	ON	ON	OFF										
SW4	ON	OFF	OFF										

The following settings are fixed; data length: 7, stop bit: 2, and parity: even.

Available Device Memory

The available setting range of device memory varies depending on the model. Be sure to set within the range available for the model to be used. Use [TYPE] when assigning indirect device memory for macro programs.

Device Memory	TYPE	Remarks
0000 Control temperature	00H	
0001 Measurement temperature		Bank No. 0
0002 Operation status		Bank No. 0
0003 Output value		Bank No. 0
0004 Output value on the cooling side		Bank No. 0
0005 Proportional band		
0006 Integral time		
0007 Derivative time		
0008 Control cycle		
0009 Control cycle on the cooling side		
000A Output operation		Bank No. 0
000B HB warning/HS warning effective channel		Bank No. 0
000C Alarm status		Bank No. 0
000D Warning mode: warning 1		Bank No. 0
000E Warning mode: warning 2		Bank No. 0
000F Temperature at which an alarm occurs: warning 1		
0010 Temperature at which an alarm occurs: warning 2		
0011 Execution memory bank No.		Bank No. 0
0012 Adjustment sensitivity		
0013 Adjustment sensitivity on the cooling side		
0014 Setting unit		Bank No. 0
0015 Input offset value		
0016 Manual reset value		
0017 Current control temperature		
0018 Output lower limit value		Bank No. 0
0019 Output upper limit value		
001A Output lower limit value on the cooling side		
001B Output upper limit value on the cooling side		
001C Limit of output change rate		
001D Heater disconnection detection (HB warning)		
001E SSR failure detection (HS warning)	Bank No. 0	
001F Heater current value	Bank No. 0	
0020 SSR leakage current value	Bank No. 0	
0021 Deadband / overlap band	Bank No. 0	
0022 Cooling coefficient		
0023 Fuzzy strength		
0024 Fuzzy scale 1		
0025 Fuzzy scale 2		

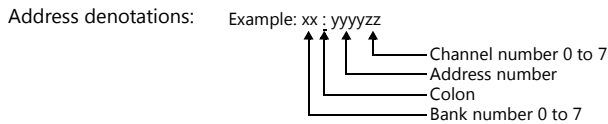

Indirect Device Memory Designation

	15	8 7	0
n + 0	Model (91 to 98)	Device type	
n + 1	Address No. (lower)	CH No.	
n + 2	00	Address No. (higher)	
n + 3	Bank No.	Bit designation	
n + 4	00	Station number	

PLC_CTL

Macro command "PLC_CTL F0 F1 F2"

Contents	F0	F1 (= \$u n)		F2
Auto tuning	1 - 8 (PLC1 - 8)	n	Station number	3
		n + 1	Command: 0	
		n + 2	0 - 7: AT start channel No. 10: Collective start at all channels 11: Sequential start at all channels 12: Cancel	
Lamp value setting	1 - 8 (PLC1 - 8)	n	Station number	5
		n + 1	Command: 1	
		n + 2	Bank No. / channel No.	
		n + 3	Lamp value	
		n + 4	Unit of time 0: Second 1: Minute 2: Hour	
Lamp value read out	1 - 8 (PLC1 - 8)	n	Station number	3
		n + 1	Command: 2	
		n + 2	Bank No. / channel No.	
		n + 3	Lamp value	
		n + 4	Unit of time 0: Second 1: Minute 2: Hour	
Setting data	1 - 8 (PLC1 - 8)	n	Station number	3
		n + 1	Command: 3	
		n + 2	0: Save 1: Initialize	
Operation control	1 - 8 (PLC1 - 8)	n	Station number	4
		n + 1	Command: 4	
		n + 2	0: Control start 1: Control stop	
		n + 3	Channel No.	
Manual operation	1 - 8 (PLC1 - 8)	n	Station number	3
		n + 1	Command: 5	
		n + 2	Channel No.	

Return data: Data stored from temperature controller to V series

13.2.11 E5ZN

Communication Setting

Editor



Communication setting

(Underlined setting: default)

Item	Setting	Remarks
Connection Mode	1 : 1 / <u>1:n</u> / Multi-link2 / Multi-link2 (Ethernet) / 1 : n Multi-link2 (Ethernet)	
Signal Level	RS-232C / <u>RS-422/485</u>	
Baud Rate	4800 / <u>9600</u> / 19200 bps	
Data Length	<u>Z</u> / 8 bits	
Stop Bit	1 / <u>2</u> bits	
Parity	None / Odd / <u>Even</u>	
Target Port No.	<u>Q</u> to 15	

Temperature Controller

(Underlined setting: default)

Item	Setting Data	Setting	
UNIT		Unit No. 0 to F (= 0 to 15)	
BPS		Baud rate 0: 4800 <u>1: 9600</u> 2: 19200 3: 38400	
Communication level	LEn	Data length	<u>Z</u> / 8 bits
	Sbit	Stop bit	1 / <u>2</u> bits
	Prty	Parity	None / <u>Even</u> / Odd
Adjustment level	CMWT	Communication writing ^{*1}	OFF / ON

*1 When writing the setting data from the V9, set "ON" for the "communication writing" setting.

Available Device Memory

The available setting range of device memory varies depending on the model. Be sure to set within the range available for the model to be used. Use [TYPE] when assigning indirect device memory for macro programs.

Device Memory	TYPE	Remarks
C0 Setting area 0	00H	Double-word, read only
C1 Setting area 0	01H	Double-word
C3 Setting area 1	02H	Double-word

Indirect Device Memory Designation

	15	8 7	0
n + 0	Model (91 to 98)	Device type	
n + 1	Address No.		
n + 2	Expansion code	Bit designation	
n + 3	00	Station number	

For bit designation, an expansion code setting is required.

00H: when designating bit 0 to 15

01H: when designating bit 16 to 31

PLC_CTL

Macro command "PLC_CTL F0 F1 F2"

Contents	F0	F1 (= \$u n)		F2
Controller status read out	1 - 8 (PLC1 - 8)	n	Station number	2
		n + 1	Command: 06H	
		n + 2	Operation status (higher byte) 00: Control in execution for all channels (Operation in progress while the setting area is "0" with no error occurring.) 01: Control stopping at any of the channels (Other than above) Related information (lower byte) 	
Operation instructions	1 - 8 (PLC1 - 8)	n	Station number *1	3
		n + 1	Command: 0030H	
		n + 2	Communication writing 0000H: Communication writing OFF (disabled) 0001H: Communication writing ON (enabled)	
			Control start/stop 0100H: Channel 1 run 0101H: Channel 1 stop 0110H: Channel 2 run 0111H: Channel 2 stop 01F0H: All-channel run *2 01F1H: All-channel stop *2	
			Multi-SP 0200H: Channel 1 target value 0 0201H: Channel 1 target value 1 0210H: Channel 2 target value 0 0211H: Channel 2 target value 1 02F0H: All-channel target value 0 *2 02F1H: All-channel target value 1 *2	
			AT execution 0300H: Channel 1 AT execute 0301H: Channel 1 AT cancel 0310H: Channel 2 AT execute 0311H: Channel 2 AT cancel 03F0H: All-channel AT execute *2 03F1H: All-channel AT cancel *2	
			Write mode 0400H: Backup mode 0401H: RAM write mode	
			0500H: Save RAM data	
			0600H: Software reset	
			0700H: Move to set area 1	
			0800H: Move to protection level	
			Auto/manual 0900H: PV hold	
			0B00H: Initialize	
Unlatch 0C00H: Channel 1 warning 1 unlatch *2 0C01H: Channel 1 warning 2 unlatch *2 0C031H: Channel 1 warning 3 unlatch *2 0C0FH: Channel 1 all warnings unlatch *2 0C10H: Channel 2 warning 1 unlatch *2 0C11H: Channel 2 warning 2 unlatch *2 0C13H: Channel 2 warning 3 unlatch *2 0C1FH: Channel 2 all warnings unlatch *2 0CF0H: All channels warning 1 unlatch *2 0CF1H: All channels warning 2 unlatch *2 0CF2H: All channels warning 3 unlatch *2 0CFH: All channels all warnings unlatch *2				

Return data: Data stored from temperature controller to V series

*1 8000 (HEX): broadcasting

*2 Valid only for the product of pulse output type or analog output type

13.2.12 V600/620/680

Communication Setting

Editor

Communication setting

(Underlined setting: default)

Item	Setting	Remarks
Connection Mode	1 : 1 / <u>1 : n</u> / Multi-link2 / Multi-link2 (Ethernet) / 1 : n Multi-link2 (Ethernet)	
Signal Level	<u>RS-232C</u> / RS-422/485	
Baud Rate	4800 / 9600 / <u>19200</u> / 38400 / 115K bps	
Data Length	<u>7</u> / 8 bits	
Stop Bit	1 / <u>2</u> bits	
Parity	None / Odd / <u>Even</u>	
Target Port No.	<u>0</u> to 31	
Transmission Mode	1 : 1 procedure / <u>1 : N procedure</u>	The transmission mode is set according to the connection mode. 1 : 1 → 1 : 1 procedure 1 : n → 1 : N procedure Multi-link2 → 1 : 1 procedure / 1 : N procedure

Device memory map setting

Reading or writing to/from the tag can be performed by using the [Synchronized Reading/Synchronized Writing] function of the device memory map.

- Synchronized reading

Reading starts when the control device memory (command bit) is set (ON). Reading is performed at specified cycles until the control device memory (acknowledge bit) is set (ON).

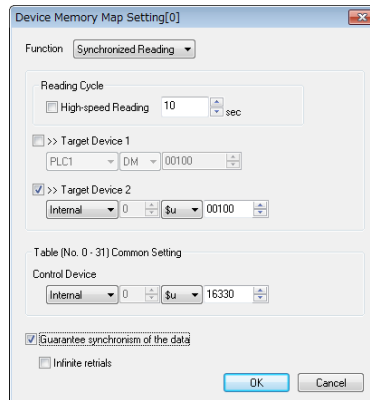

Item	Contents
Reading Cycle	The data at the device memory addresses registered in the device memory map is read when the control device memory (command bit) is set (ON). Reading of data is repeated at specified cycles until the data is read correctly. When the data has correctly been read, the control device memory (acknowledge bit) is set (ON) and reading operation finishes. ^{*1}
Control Device	Enter a device memory address as the trigger for synchronized reading. The specified address is used for the device memory map Nos. 0 to 31. Four words are occupied. For more information, see the V9 Series Reference Manual.
Guarantee synchronism of the data	When the box is checked, retry is made until the first data in the device memory map is read correctly. ^{*2 *3} Check the status/error codes at \$Pn 356 to 451 to confirm whether or not reading of subsequent data has been completed successfully.
Infinite retrials	When the box is checked, retry is made until all data in the device memory map is read correctly. ^{*3} Status/error codes are stored in \$Pn 356 to 451.

^{*1} When both [Guarantee synchronism of the data] and [Infinite retrials] are not checked, the acknowledge bit is set (ON) when reading of any data at the device memory address registered in the device memory map has been completed successfully.

^{*2} Set the device memory address of the same station number and channel in the device memory map.

^{*3} This setting is invalid when the macro command "TBL_READ" is executed.

- Synchronized writing
Writing starts when the control device memory (command bit) is set (ON). When writing has been finished, the control device memory (acknowledge bit) is set (ON).

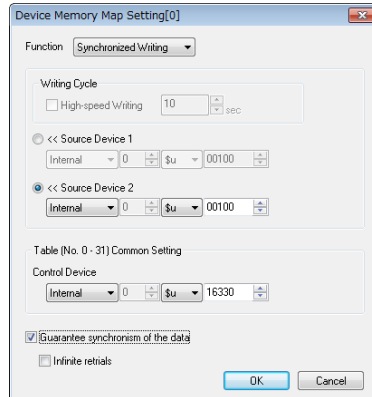

Item	Contents
Writing Cycle	The data is written into the device memory addresses registered in the device memory map when the control device memory (command bit) is set (ON). When writing of data finishes, the control device memory (acknowledge bit) is set (ON) regardless of the result of the writing status.
Control Device	Enter a device memory address as the trigger for synchronized writing. The specified address is used for the device memory map Nos. 0 to 31. Four words are occupied. For more information, see the V9 Series Reference Manual.
Guarantee synchronism of the data	When the box is checked, retry is made until the first data is correctly written into the address registered in the device memory map.*1 Check the status/error codes at \$Pn 356 to 451 to confirm whether or not writing of subsequent data has been completed successfully.
Infinite retrials	When the box is checked, retry is made until all data is correctly written into the addresses registered in the device memory map.*1 Status/error codes are stored in \$Pn 356 to 451.

*1 Set the device memory address of the same station number and channel in the device memory map.
*2 This setting is invalid when the macro command "TBL_WRITE" is executed.

ID Controller

V600-CA1A/V600-CA2A

(Default: OFF (all))

DIP Switch		Setting																																							
	SW1 SW2 SW3	Baud rate setting <table border="1"> <thead> <tr> <th>SW1</th> <th>SW2</th> <th>SW3</th> <th>Baud Rate</th> </tr> </thead> <tbody> <tr> <td>ON</td> <td>OFF</td> <td>ON</td> <td>4800</td> </tr> <tr> <td>ON</td> <td>ON</td> <td>OFF</td> <td>9600</td> </tr> <tr> <td>ON</td> <td>ON</td> <td>ON</td> <td>19200</td> </tr> </tbody> </table>	SW1	SW2	SW3	Baud Rate	ON	OFF	ON	4800	ON	ON	OFF	9600	ON	ON	ON	19200																							
	SW1	SW2	SW3	Baud Rate																																					
	ON	OFF	ON	4800																																					
ON	ON	OFF	9600																																						
ON	ON	ON	19200																																						
SW4 SW5 SW6	Communication format <table border="1"> <thead> <tr> <th>SW4</th> <th>SW5</th> <th>SW6</th> <th>Data Length</th> <th>Stop Bit</th> <th>Parity</th> </tr> </thead> <tbody> <tr> <td>OFF</td> <td>OFF</td> <td>OFF</td> <td rowspan="3">7</td> <td rowspan="2">2</td> <td>Even</td> </tr> <tr> <td>OFF</td> <td>OFF</td> <td>ON</td> <td>Odd</td> </tr> <tr> <td>OFF</td> <td>ON</td> <td>OFF</td> <td rowspan="4">8</td> <td rowspan="2">1</td> <td>Even</td> </tr> <tr> <td>OFF</td> <td>ON</td> <td>ON</td> <td>Odd</td> </tr> <tr> <td>ON</td> <td>OFF</td> <td>OFF</td> <td rowspan="3">2</td> <td rowspan="3">1</td> <td>None</td> </tr> <tr> <td>ON</td> <td>OFF</td> <td>ON</td> <td>Even</td> </tr> <tr> <td>ON</td> <td>ON</td> <td>OFF</td> <td>Odd</td> </tr> </tbody> </table>	SW4	SW5	SW6	Data Length	Stop Bit	Parity	OFF	OFF	OFF	7	2	Even	OFF	OFF	ON	Odd	OFF	ON	OFF	8	1	Even	OFF	ON	ON	Odd	ON	OFF	OFF	2	1	None	ON	OFF	ON	Even	ON	ON	OFF	Odd
SW4	SW5	SW6	Data Length	Stop Bit	Parity																																				
OFF	OFF	OFF	7	2	Even																																				
OFF	OFF	ON			Odd																																				
OFF	ON	OFF		8	1	Even																																			
OFF	ON	ON	Odd																																						
ON	OFF	OFF	2		1	None																																			
ON	OFF	ON				Even																																			
ON	ON	OFF		Odd																																					
SW7 SW8	Always OFF																																								

DIP Switch		Setting																																																																																																			
<p>DIP switch 2</p> 	<p>SW2 SW3 SW4 SW5</p>	Unit No. (Valid only when "1 : N" is selected by SW6. When "1 : 1" is selected, set all switches to the OFF positions.)																																																																																																			
		<table border="1"> <thead> <tr> <th>SW2</th> <th>SW3</th> <th>SW4</th> <th>SW5</th> <th>No.</th> </tr> </thead> <tbody> <tr><td>OFF</td><td>OFF</td><td>OFF</td><td>OFF</td><td>0</td></tr> <tr><td>OFF</td><td>OFF</td><td>OFF</td><td>ON</td><td>1</td></tr> <tr><td>OFF</td><td>OFF</td><td>ON</td><td>OFF</td><td>2</td></tr> <tr><td>OFF</td><td>OFF</td><td>ON</td><td>ON</td><td>3</td></tr> <tr><td>OFF</td><td>ON</td><td>OFF</td><td>OFF</td><td>4</td></tr> <tr><td>OFF</td><td>ON</td><td>OFF</td><td>ON</td><td>5</td></tr> <tr><td>OFF</td><td>ON</td><td>ON</td><td>OFF</td><td>6</td></tr> <tr><td>OFF</td><td>ON</td><td>ON</td><td>ON</td><td>7</td></tr> </tbody> </table>					SW2	SW3	SW4	SW5	No.	OFF	OFF	OFF	OFF	0	OFF	OFF	OFF	ON	1	OFF	OFF	ON	OFF	2	OFF	OFF	ON	ON	3	OFF	ON	OFF	OFF	4	OFF	ON	OFF	ON	5	OFF	ON	ON	OFF	6	OFF	ON	ON	ON	7	<table border="1"> <thead> <tr> <th>SW2</th> <th>SW3</th> <th>SW4</th> <th>SW5</th> <th>No.</th> </tr> </thead> <tbody> <tr><td>ON</td><td>OFF</td><td>OFF</td><td>OFF</td><td>8</td></tr> <tr><td>ON</td><td>OFF</td><td>OFF</td><td>ON</td><td>9</td></tr> <tr><td>ON</td><td>OFF</td><td>ON</td><td>OFF</td><td>10</td></tr> <tr><td>ON</td><td>OFF</td><td>ON</td><td>ON</td><td>11</td></tr> <tr><td>ON</td><td>ON</td><td>OFF</td><td>OFF</td><td>12</td></tr> <tr><td>ON</td><td>ON</td><td>OFF</td><td>ON</td><td>13</td></tr> <tr><td>ON</td><td>ON</td><td>ON</td><td>OFF</td><td>14</td></tr> <tr><td>ON</td><td>ON</td><td>ON</td><td>ON</td><td>15</td></tr> </tbody> </table>					SW2	SW3	SW4	SW5	No.	ON	OFF	OFF	OFF	8	ON	OFF	OFF	ON	9	ON	OFF	ON	OFF	10	ON	OFF	ON	ON	11	ON	ON	OFF	OFF	12	ON	ON	OFF	ON	13	ON	ON	ON	OFF	14	ON	ON	ON	ON	15
		SW2	SW3	SW4	SW5	No.																																																																																															
		OFF	OFF	OFF	OFF	0																																																																																															
OFF	OFF	OFF	ON	1																																																																																																	
OFF	OFF	ON	OFF	2																																																																																																	
OFF	OFF	ON	ON	3																																																																																																	
OFF	ON	OFF	OFF	4																																																																																																	
OFF	ON	OFF	ON	5																																																																																																	
OFF	ON	ON	OFF	6																																																																																																	
OFF	ON	ON	ON	7																																																																																																	
SW2	SW3	SW4	SW5	No.																																																																																																	
ON	OFF	OFF	OFF	8																																																																																																	
ON	OFF	OFF	ON	9																																																																																																	
ON	OFF	ON	OFF	10																																																																																																	
ON	OFF	ON	ON	11																																																																																																	
ON	ON	OFF	OFF	12																																																																																																	
ON	ON	OFF	ON	13																																																																																																	
ON	ON	ON	OFF	14																																																																																																	
ON	ON	ON	ON	15																																																																																																	
SW6	Communication protocol OFF: 1 : 1 ON: 1 : N																																																																																																				
SW7	Terminating resistance at sending side (valid only for RS-422) OFF: Not provided ON: Provided																																																																																																				
SW8	Terminating resistance at receiving side (valid only for RS-422) OFF: Not provided ON: Provided																																																																																																				

V600-CD1D

(Default: OFF (all))

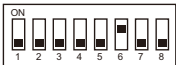
DIP Switch		Setting																																																				
<p>DIP switch 1</p> 	<p>SW2 SW3</p>	Baud rate setting																																																				
		<table border="1"> <thead> <tr> <th>SW2</th> <th>SW3</th> <th>Baud Rate</th> </tr> </thead> <tbody> <tr><td>OFF</td><td>ON</td><td>4800</td></tr> <tr><td>ON</td><td>OFF</td><td>9600</td></tr> <tr><td>ON</td><td>ON</td><td>19200</td></tr> </tbody> </table>										SW2	SW3	Baud Rate	OFF	ON	4800	ON	OFF	9600	ON	ON	19200																															
	SW2	SW3	Baud Rate																																																			
OFF	ON	4800																																																				
ON	OFF	9600																																																				
ON	ON	19200																																																				
<p>SW4 SW5 SW6</p>	Communication format																																																					
	<table border="1"> <thead> <tr> <th>SW4</th> <th>SW5</th> <th>SW6</th> <th>Data Length</th> <th>Stop Bit</th> <th>Parity</th> </tr> </thead> <tbody> <tr> <td>OFF</td> <td>OFF</td> <td>OFF</td> <td rowspan="3">7</td> <td rowspan="3">2</td> <td>Even</td> </tr> <tr> <td>OFF</td> <td>OFF</td> <td>ON</td> <td>Odd</td> </tr> <tr> <td>OFF</td> <td>ON</td> <td>OFF</td> <td rowspan="3">1</td> <td>Even</td> </tr> <tr> <td>OFF</td> <td>ON</td> <td>ON</td> <td>Odd</td> </tr> <tr> <td>ON</td> <td>OFF</td> <td>OFF</td> <td rowspan="4">8</td> <td rowspan="4">2</td> <td>None</td> </tr> <tr> <td>ON</td> <td>OFF</td> <td>ON</td> <td rowspan="3">1</td> <td>Even</td> </tr> <tr> <td>ON</td> <td>ON</td> <td>OFF</td> <td>Odd</td> </tr> <tr> <td>ON</td> <td>ON</td> <td>ON</td> <td>Odd</td> </tr> </tbody> </table>										SW4	SW5	SW6	Data Length	Stop Bit	Parity	OFF	OFF	OFF	7	2	Even	OFF	OFF	ON	Odd	OFF	ON	OFF	1	Even	OFF	ON	ON	Odd	ON	OFF	OFF	8	2	None	ON	OFF	ON	1	Even	ON	ON	OFF	Odd	ON	ON	ON	Odd
	SW4	SW5	SW6	Data Length	Stop Bit	Parity																																																
	OFF	OFF	OFF	7	2	Even																																																
	OFF	OFF	ON			Odd																																																
	OFF	ON	OFF			1	Even																																															
	OFF	ON	ON	Odd																																																		
ON	OFF	OFF	8	2	None																																																	
ON	OFF	ON			1	Even																																																
ON	ON	OFF				Odd																																																
ON	ON	ON				Odd																																																
SW8	Always OFF																																																					
<p>DIP switch 2</p> 	<p>SW3 SW4 SW5</p>	Unit No. (Valid only when "1 : N" is selected by SW6. When "1 : 1" is selected, set all switches to the OFF positions.)																																																				
		<table border="1"> <thead> <tr> <th>SW3</th> <th>SW4</th> <th>SW5</th> <th>Unit No.</th> </tr> </thead> <tbody> <tr><td>OFF</td><td>OFF</td><td>OFF</td><td>0</td></tr> <tr><td>OFF</td><td>OFF</td><td>ON</td><td>1</td></tr> <tr><td>OFF</td><td>ON</td><td>OFF</td><td>2</td></tr> <tr><td>OFF</td><td>ON</td><td>ON</td><td>3</td></tr> <tr><td>ON</td><td>OFF</td><td>OFF</td><td>4</td></tr> <tr><td>ON</td><td>OFF</td><td>ON</td><td>5</td></tr> <tr><td>ON</td><td>ON</td><td>OFF</td><td>6</td></tr> <tr><td>ON</td><td>ON</td><td>ON</td><td>7</td></tr> </tbody> </table>										SW3	SW4	SW5	Unit No.	OFF	OFF	OFF	0	OFF	OFF	ON	1	OFF	ON	OFF	2	OFF	ON	ON	3	ON	OFF	OFF	4	ON	OFF	ON	5	ON	ON	OFF	6	ON	ON	ON	7							
		SW3	SW4	SW5	Unit No.																																																	
		OFF	OFF	OFF	0																																																	
		OFF	OFF	ON	1																																																	
		OFF	ON	OFF	2																																																	
		OFF	ON	ON	3																																																	
	ON	OFF	OFF	4																																																		
ON	OFF	ON	5																																																			
ON	ON	OFF	6																																																			
ON	ON	ON	7																																																			
SW6	Communication protocol OFF: 1 : 1 ON: 1 : N																																																					
SW7 SW8	Always OFF																																																					

V680

(Default: OFF (all))

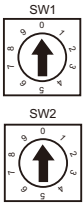
Switch Setting		Setting															
SW1 SW2	Controller No. setting	0 to 31 (32 to 99: not available) 															
SW3-1	Switch selection	OFF: DIP switch enabled															
SW3-3 SW3-4	Baud rate setting	<table border="1"> <thead> <tr> <th>SW3-3</th> <th>SW3-4</th> <th>Baud Rate</th> </tr> </thead> <tbody> <tr> <td>OFF</td> <td>OFF</td> <td>9600</td> </tr> <tr> <td>OFF</td> <td>ON</td> <td>19200</td> </tr> <tr> <td>ON</td> <td>OFF</td> <td>38400</td> </tr> <tr> <td>ON</td> <td>ON</td> <td>115200</td> </tr> </tbody> </table>	SW3-3	SW3-4	Baud Rate	OFF	OFF	9600	OFF	ON	19200	ON	OFF	38400	ON	ON	115200
SW3-3	SW3-4	Baud Rate															
OFF	OFF	9600															
OFF	ON	19200															
ON	OFF	38400															
ON	ON	115200															
SW3-5	Data length setting	OFF: 7 bits ON: 8 bits															
SW3-6 SW3-7	Parity	<table border="1"> <thead> <tr> <th>SW3-6</th> <th>SW3-7</th> <th>Parity</th> </tr> </thead> <tbody> <tr> <td>OFF</td> <td>OFF</td> <td>Even</td> </tr> <tr> <td>OFF</td> <td>ON</td> <td>None</td> </tr> <tr> <td>ON</td> <td>OFF</td> <td>Odd</td> </tr> <tr> <td>ON</td> <td>ON</td> <td>Even</td> </tr> </tbody> </table>	SW3-6	SW3-7	Parity	OFF	OFF	Even	OFF	ON	None	ON	OFF	Odd	ON	ON	Even
SW3-6	SW3-7	Parity															
OFF	OFF	Even															
OFF	ON	None															
ON	OFF	Odd															
ON	ON	Even															
SW3-8	Stop bit	OFF: 2 bits ON: 1 bit															
SW3-9	Communication protocol	OFF: 1 : 1 ON: 1 : N															
SW3-10	Command system	ON: V600 command format															

Available Device Memory

The available setting range of device memory varies depending on the model. Be sure to set within the range available for the model to be used. Use [TYPE] when assigning indirect device memory for macro programs.

Device Memory		TYPE	Remarks
--	Setting area 0	00H	

Indirect Device Memory Designation

	15	8 7	0
n + 0	Model (91 to 98)		Device type
n + 1	Address No.		
n + 2	Channel No.		Bit designation
n + 3	00		Station number

PLC_CTL

Macro command "PLC_CTL F0 F1 F2"

Contents	F0	F1 (= \$u n)		F2
Read (specified with ASCII code) Channel 1	1 - 8 (PLC1 - 8)	n	Station number	4
		n + 1	Command: 0	
		n + 2	Top address	
		n + 3	Word count: m	
		n + 4 to n + (3 + m)	Read data	
Write (specified with ASCII code) Channel 1	1 - 8 (PLC1 - 8)	n	Station number	4 + m
		n + 1	Command: 1	
		n + 2	Top address	
		n + 3	Word count: m	
		n + 4 to n + (3 + m)	Write data	
Command process abort	1 - 8 (PLC1 - 8)	n	Station number	2
		n + 1	Command: 2	
Data management Channel 1 Data check command: compare	1 - 8 (PLC1 - 8)	n	Station number	4
		n + 1	Command: 3	
		n + 2	Top address	
		n + 3	Bytes	
Data management Channel 1 Data check command: calculation	1 - 8 (PLC1 - 8)	n	Station number	4
		n + 1	Command: 4	
		n + 2	Top address	
		n + 3	Bytes	
Data management Channel 1 Writing count management command: subtraction	1 - 8 (PLC1 - 8)	n	Station number	4
		n + 1	Command: 5	
		n + 2	Top address	
		n + 3	Number of updates	
Data management Channel 1 Writing count management command: addition	1 - 8 (PLC1 - 8)	n	Station number	4
		n + 1	Command: 6	
		n + 2	Top address	
		n + 3	Number of updates	
Repeated writing	1 - 8 (PLC1 - 8)	n	Station number	2
		n + 1	Command: 7	
Controller control	1 - 8 (PLC1 - 8)	n	Station number	4
		n + 1	Command: 8	
		n + 2	OUT1 operation 0: No operation 1: ON 2: OFF	
		n + 3	OUT2 operation 0: No operation 1: ON 2: OFF	
		n + 4	Current input status (IN1) 0: OFF 1: ON	
		n + 5	Current input status (IN2) 0: OFF 1: ON	
		n + 6	Output status after execution of operation (OUT1) 0: OFF 1: ON	
		n + 7	Output status after execution of operation (OUT2) 0: OFF 1: ON	
Error information read out	1 - 8 (PLC1 - 8)	n	Station number	2
		n + 1	Command: 9	
		n + 2 to n + 4	Latest error log information (new)	
		n + 5 to n + 91	Latest error log information (old), max. 29 logs	
Abort (reset)	1 - 8 (PLC1 - 8)	n	Station number	2
		n + 1	Command: 10	
Exit code acquisition Channel 1	1 - 8 (PLC1 - 8)	n	Station number	2
		n + 1	Command: 12	
		n + 2	Exit code *1	

Contents	F0	F1 (= \$u n)		F2
Read (specified with ASCII code) Channel 2	1 - 8 (PLC1 - 8)	n	Station number	4
		n + 1	Command: 100	
		n + 2	Top address	
		n + 3	Word count: m	
		n + 4 to n + (3 + m)	Read data	
Write (specified with ASCII code) Channel 2	1 - 8 (PLC1 - 8)	n	Station number	4 + m
		n + 1	Command: 101	
		n + 2	Top address	
		n + 3	Word count: m	
		n + 4 to n + (3 + m)	Write data	
Data management Channel 2 Data check command: compare	1 - 8 (PLC1 - 8)	n	Station number	4
		n + 1	Command: 103	
		n + 2	Top address	
		n + 3	Bytes	
Data management Channel 2 Data check command: calculation	1 - 8 (PLC1 - 8)	n	Station number	4
		n + 1	Command: 104	
		n + 2	Top address	
		n + 3	Bytes	
Data management Channel 2 Writing count management command: subtraction	1 - 8 (PLC1 - 8)	n	Station number	4
		n + 1	Command: 105	
		n + 2	Top address	
		n + 3	Number of updates	
Data management Channel 2 Writing count management command: addition	1 - 8 (PLC1 - 8)	n	Station number	4
		n + 1	Command: 106	
		n + 2	Top address	
		n + 3	Number of updates	
Exit code acquisition Channel 2	1 - 8 (PLC1 - 8)	n	Station number	2
		n + 1	Command: 112	
		n + 2	Exit code ^{*1}	

Return data: Data stored from temperature controller to V series

*1 The exit code will not be stored if it cannot be acquired due to timeout or other reasons.

Operation

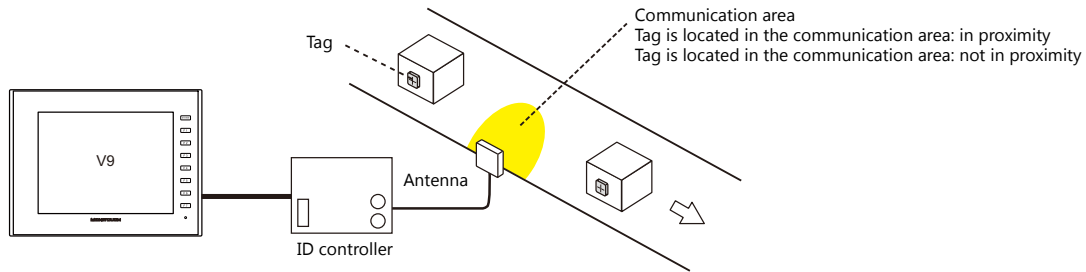

When a tag is located in proximity:

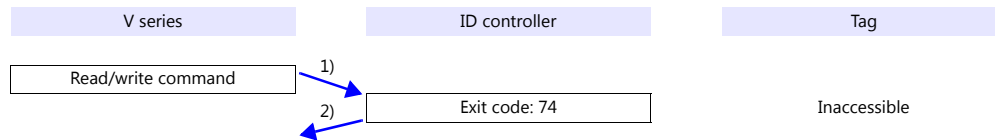

- 1) The V series sends the read/write command.
- 2) Since the tag is not located in an accessible position, the V series receives exit code 74 from the ID controller.
- 3) When [Synchronized Reading] is selected in the [Device Memory Map Setting] dialog and the control device memory (command bit) is set (ON):
 - 1) is executed at cycles specified for [Reading Cycle].

When a tag is not located in proximity (reading/writing possible):

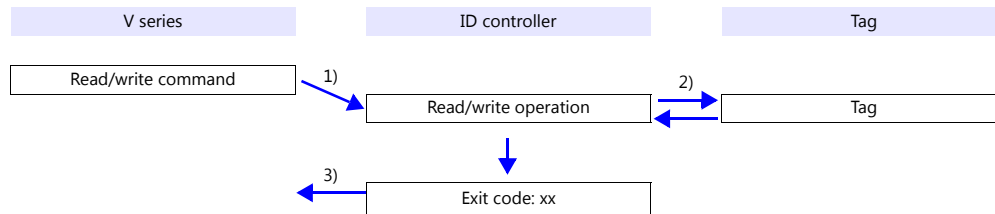

- 1) The V series sends the read/write command.
- 2) The ID controller executes reading/writing from/into the tag.
- 3) The V series receives the exit code from the ID controller.
 - Exit code (00, 74): Finish
 - Exit code (other than 00 or 74): Steps 1) to 3) are repeated the set number of retrial times.

System Device Memory

\$Pn: 356 to 451

When [Guarantee synchronism of the data] is checked in the [Device Memory Map Setting] dialog, a status/error code of each device memory map is stored here. For more information, see "1.5 System Device Memory for Communication Confirmation" (page 1-55).

13.2.13 KM20

Communication Setting

Editor

Communication setting

(Underlined setting: default)

Item	Setting	Remarks
Connection Mode	1 : 1 / <u>1 : n</u> / Multi-link2 / Multi-link2 (Ethernet) / 1 : n Multi-link2 (Ethernet)	
Signal Level	RS-232C / <u>RS-422/485</u>	
Baud Rate	4800 / <u>9600</u> / 19200 / 38400 bps	
Data Length	<u>7</u> / 8 bits	
Stop Bit	1 / <u>2</u> bits	
Parity	None / Odd / <u>Even</u>	
Target Port No.	<u>0</u> to 99	

Temperature Controller

Communication setting switch

COMMUNICATION SETTING SW		Setting Data	Remarks																				
SW1 SW2 SW3	Baud rate	<table border="1"> <thead> <tr> <th>SW1</th> <th>SW2</th> <th>SW3</th> <th>Baud Rate</th> </tr> </thead> <tbody> <tr> <td>ON</td> <td>ON</td> <td>OFF</td> <td>4800</td> </tr> <tr> <td>OFF</td> <td>OFF</td> <td>OFF</td> <td>9600</td> </tr> <tr> <td>ON</td> <td>OFF</td> <td>ON</td> <td>19200</td> </tr> <tr> <td>OFF</td> <td>ON</td> <td>ON</td> <td>38400</td> </tr> </tbody> </table>	SW1	SW2	SW3	Baud Rate	ON	ON	OFF	4800	OFF	OFF	OFF	9600	ON	OFF	ON	19200	OFF	ON	ON	38400	
SW1	SW2	SW3	Baud Rate																				
ON	ON	OFF	4800																				
OFF	OFF	OFF	9600																				
ON	OFF	ON	19200																				
OFF	ON	ON	38400																				
SW4	Data bits	OFF: 7 bits ON: 8 bits																					
SW5	Stop bit	OFF: 2 bits ON: 1 bit																					
SW6 SW7	Parity	<table border="1"> <thead> <tr> <th>SW6</th> <th>SW7</th> <th>Parity</th> </tr> </thead> <tbody> <tr> <td>OFF</td> <td>OFF</td> <td>Even</td> </tr> <tr> <td>ON</td> <td>OFF</td> <td>Odd</td> </tr> <tr> <td>OFF</td> <td>ON</td> <td>None</td> </tr> </tbody> </table>	SW6	SW7	Parity	OFF	OFF	Even	ON	OFF	Odd	OFF	ON	None									
SW6	SW7	Parity																					
OFF	OFF	Even																					
ON	OFF	Odd																					
OFF	ON	None																					
SW8	Priority setting	OFF: DIP switch setting ON: RS-485 communication setting	CT/SACT setting																				
SW9 SW10	Circuit setting	<table border="1"> <thead> <tr> <th>SW6</th> <th>SW7</th> <th>Circuit</th> </tr> </thead> <tbody> <tr> <td>OFF</td> <td>OFF</td> <td>Three-phase three-wire</td> </tr> <tr> <td>ON</td> <td>OFF</td> <td>Single-phase two-wire</td> </tr> <tr> <td>OFF</td> <td>ON</td> <td>Single-phase three-wire</td> </tr> </tbody> </table>	SW6	SW7	Circuit	OFF	OFF	Three-phase three-wire	ON	OFF	Single-phase two-wire	OFF	ON	Single-phase three-wire	Set this switch correctly according to the measurement environment. Otherwise, measurement cannot be performed correctly.								
SW6	SW7	Circuit																					
OFF	OFF	Three-phase three-wire																					
ON	OFF	Single-phase two-wire																					
OFF	ON	Single-phase three-wire																					

Unit No. setting switch

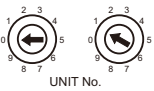
UNIT No.	Setting Data	Remarks
	00 to 99	

Available Device Memory

The available setting range of device memory varies depending on the model. Be sure to set within the range available for the model to be used. Use [TYPE] when assigning indirect device memory for macro programs.

Device Memory	TYPE	Remarks
C0 Variable area (instantaneous value)	00H	Double-word, read only
C2 Variable area (maximum value)	02H	Double-word, read only
C3 Variable area (minimum value)	03H	Double-word, read only
C000 Parameter area	04H	Double-word

Indirect Device Memory Designation

	15	8 7	0
n + 0	Model (91 to 98)	Device type	
n + 1	Address No.		
n + 2	Expansion code	Bit designation	
n + 3	00	Station number	

For bit designation, an expansion code setting is required.

00H: when designating bit 0 to 15

01H: when designating bit 16 to 31

PLC_CTL

Macro command "PLC_CTL F0 F1 F2"

Contents	F0	F1 (= \$u n)	F2
Status read out	1 - 8 (PLC1 - 8)	n	Station number
		n + 1	Command: 06H
		n + 2	Operation status
Operation instructions	1 - 8 (PLC1 - 8)	n	Station number ^{*1}
		n + 1	Command: 30H
		n + 2	0300H: Integral power consumption zero reset 1200H: Maximum of each measurement value reset 1300H: Minimum of each measurement value reset 9900H: Software reset

 Return data: Data stored from temperature controller to V series

*1 8000 (HEX): broadcasting

13.2.14 KM100

Communication Setting

Editor

Communication setting

(Underlined setting: default)

Item	Setting	Remarks
Connection Mode	1 : 1 / <u>1 : n</u> / Multi-link2 / Multi-link2 (Ethernet) / 1 : n Multi-link2 (Ethernet)	
Signal Level	RS-232C / <u>RS-422/485</u>	
Baud Rate	4800 / <u>9600</u> / 19200 / 38400 bps	
Data Length	<u>7</u> / 8 bits	
Stop Bit	1 / <u>2</u> bits	
Parity	None / Odd / <u>Even</u>	
Target Port No.	<u>0</u> to 99	

Temperature Controller

Communication level

Move to the communication setting level by using the key on the operation panel and make the required settings.

When the [LEVEL] key is held down for three seconds or longer in the run level, the setting level is selected.

When the [LEVEL] key is pressed in the setting level, the communication setting level is selected.

When the [LEVEL] key is held down for one second or longer, the run level is selected again.

(Underlined setting: default)

Item	Setting	Remarks
Communication unit No.	U-no 00 to 99	
Baud rate	bPS 4800 / <u>9600</u> / 19200 / 38400	
Data length	LEn <u>7</u> / 8	
Stop bit	Sbit 1 / <u>2</u>	
Parity	Prty None / <u>Even</u> / Odd	

Available Device Memory

The available setting range of device memory varies depending on the model. Be sure to set within the range available for the model to be used. Use [TYPE] when assigning indirect device memory for macro programs.

Device Memory	TYPE	Remarks
C0 Variable area (instantaneous value)	00H	Double-word, read only
C1 Variable area (average value)	01H	Double-word, read only
C2 Variable area (maximum value)	02H	Double-word, read only
C000 Parameter area	04H	Double-word

Indirect Device Memory Designation

	15	8 7	0
n + 0	Model (91 to 98)		Device type
n + 1	Address No.		
n + 2	Expansion code		Bit designation
n + 3	00		Station number

For bit designation, an expansion code setting is required.

00H: when designating bit 0 to 15

01H: when designating bit 16 to 31

PLC_CTL

Macro command "PLC_CTL F0 F1 F2"

Contents	F0	F1 (= \$u n)		F2
Status read out	1 - 8 (PLC1 - 8)	n	Station number	2
		n + 1	Command: 06H	
		n + 2	Operation status	
Operation instructions	1 - 8 (PLC1 - 8)	n	Station number *1	3
		n + 1	Command: 30H	
		n + 2	0000H: Start calculation of arbitrary integral power consumption	
			0100H: Stop calculation of arbitrary integral power consumption	
			0200H: Arbitrary integral power consumption zero reset	
			0300H: Integral power consumption zero reset	
			0700H: Move to setting level	
			Log data read out	
			1000H: Moving the read pointer to the top of the stored data	
		1001H: Reading the log data at the read pointer (The pointer advances.)		
		1002H: Reading the log data at the read pointer and delete the read data and earlier data from the memory (The pointer advances.)		
1100H: Delete all log data				
9900H: Software reset				

 Return data: Data stored from temperature controller to V series

*1 8000 (HEX): broadcasting

13.2.15 Wiring Diagrams

When Connected at CN1:

RS-232C

Wiring diagram 1 - C2

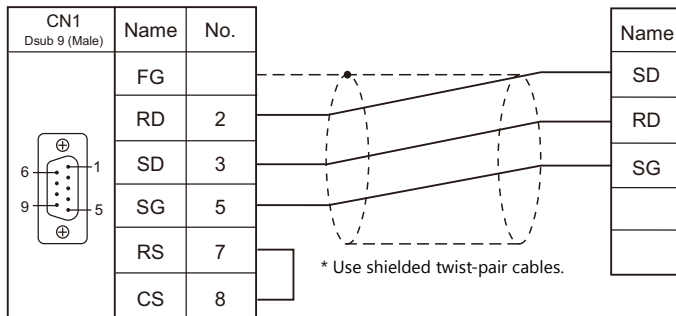

Wiring diagram 2 - C2

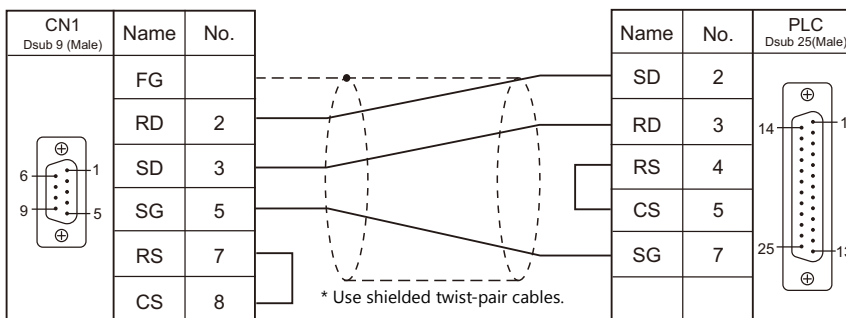

Wiring diagram 3 - C2

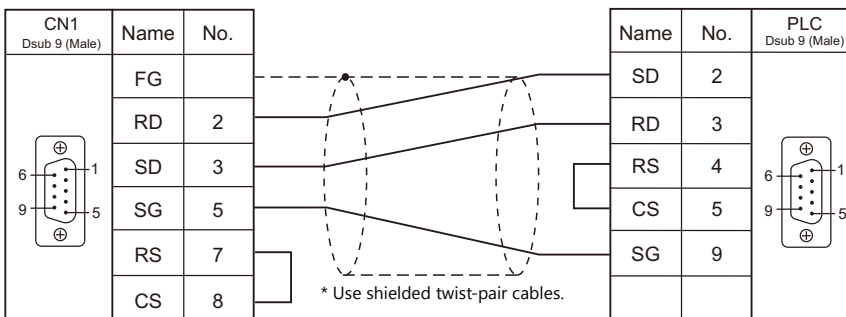

Wiring diagram 4 - C2

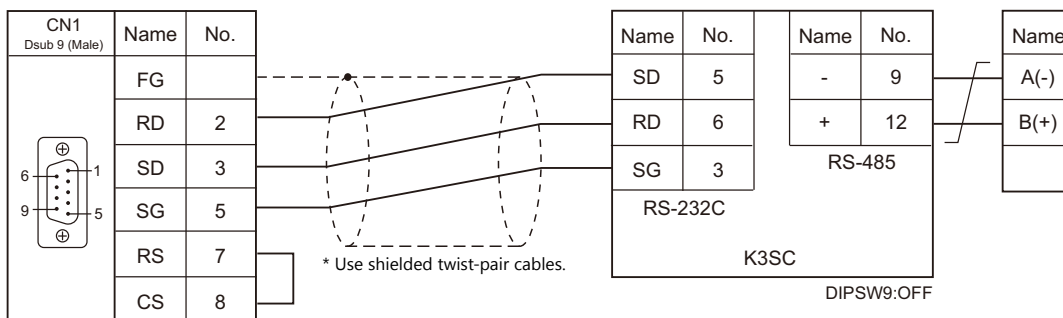

RS-422/RS-485

Wiring diagram 1 - C4

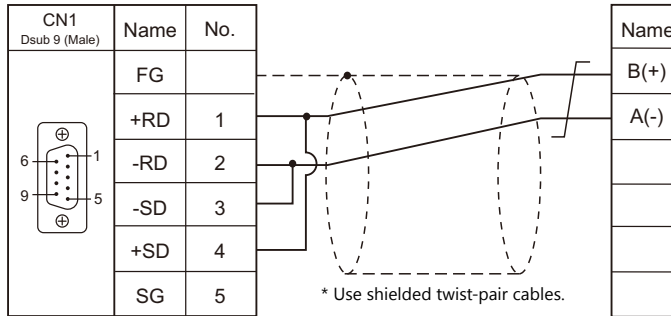

Wiring diagram 2 - C4

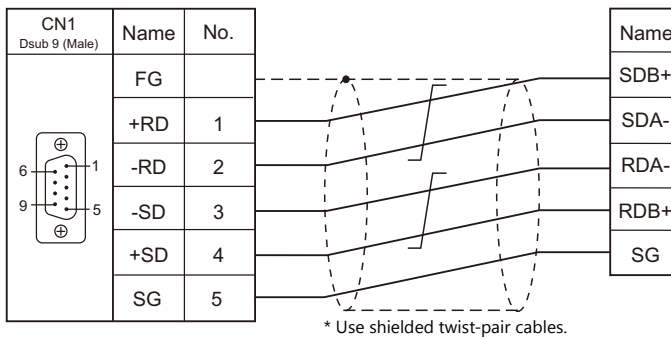

Wiring diagram 3 - C4

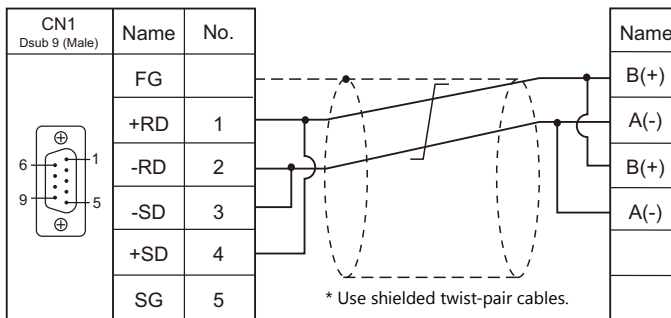

Wiring diagram 4 - C4

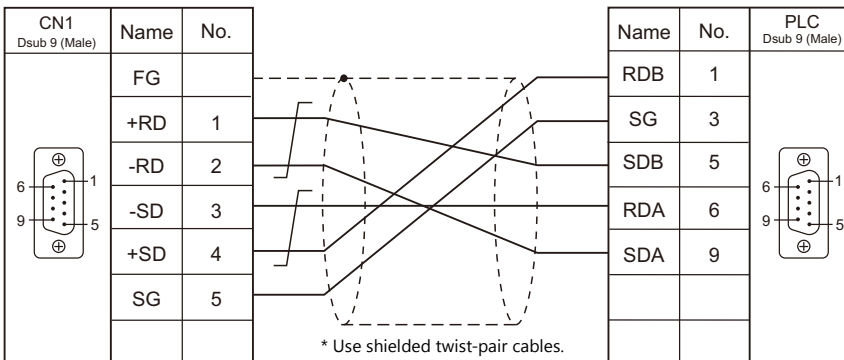

Wiring diagram 5 - C4

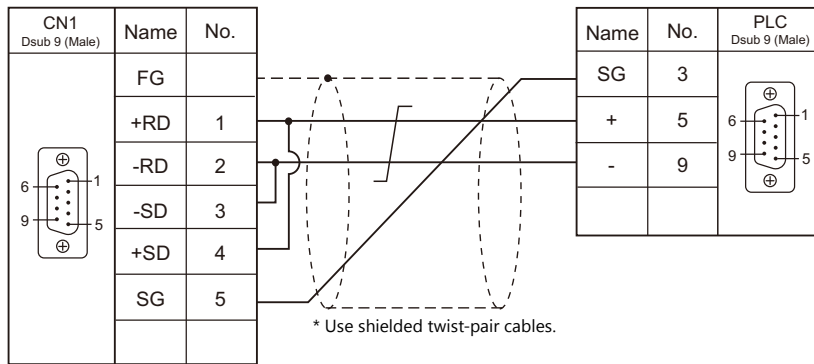

When Connected at MJ1/MJ2:

RS-232C

Wiring diagram 1 - M2

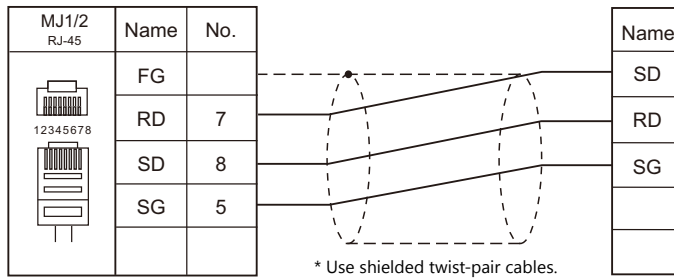

Wiring diagram 2 - M2

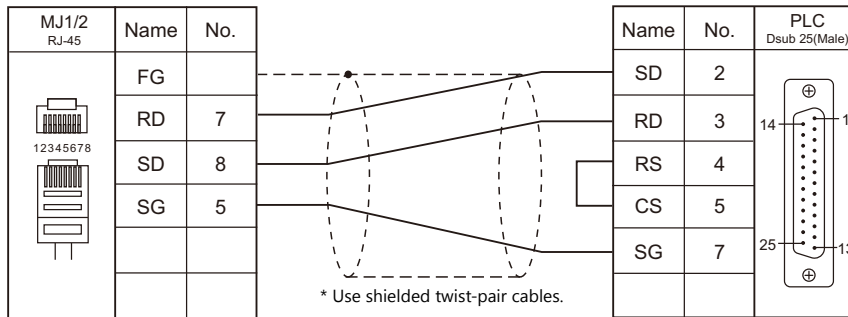

Wiring diagram 3 - M2

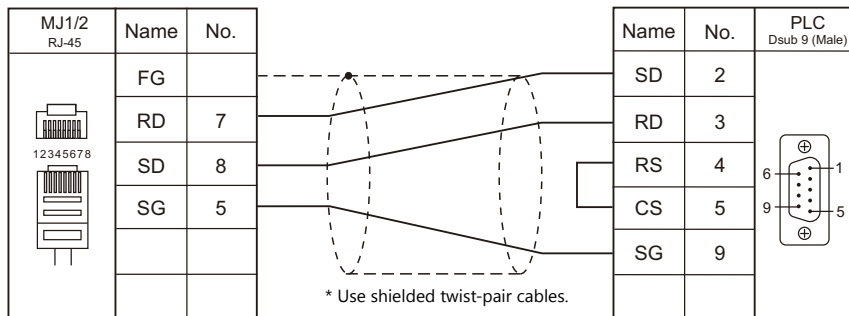

Wiring diagram 4 - M2

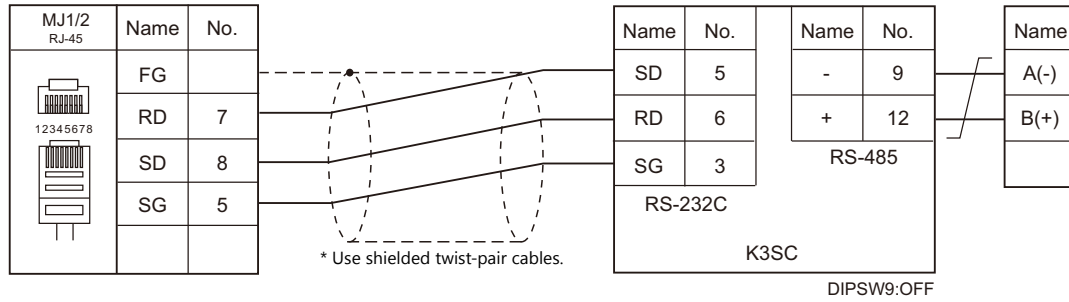

RS-422/RS-485

Wiring diagram 1 - M4

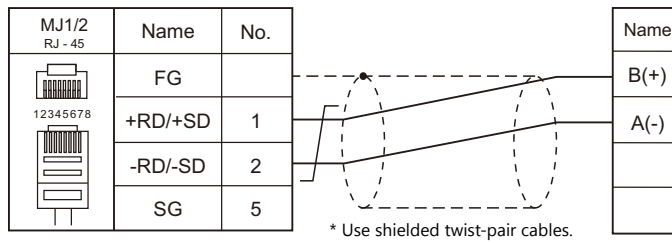

Wiring diagram 2 - M4

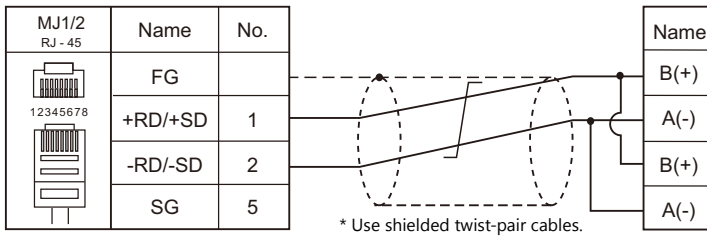

Wiring diagram 3 - M4

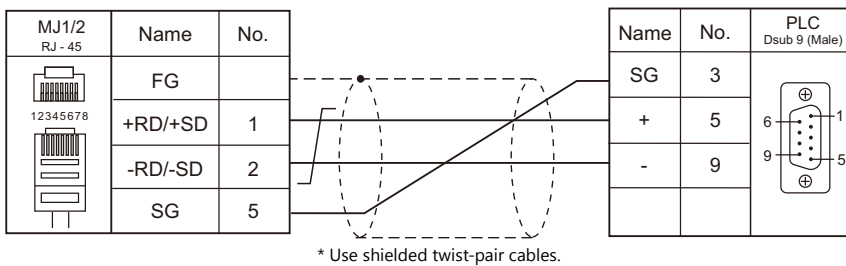

Wiring diagram 4 - M4

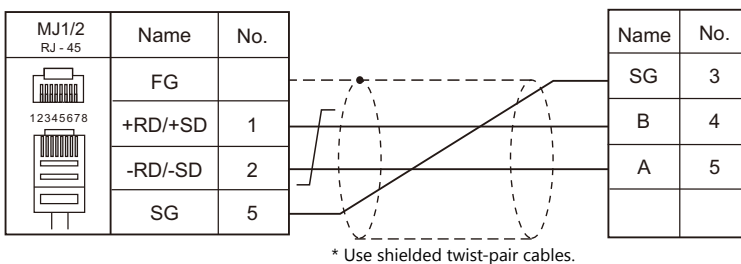

Wiring diagram 5 - M4

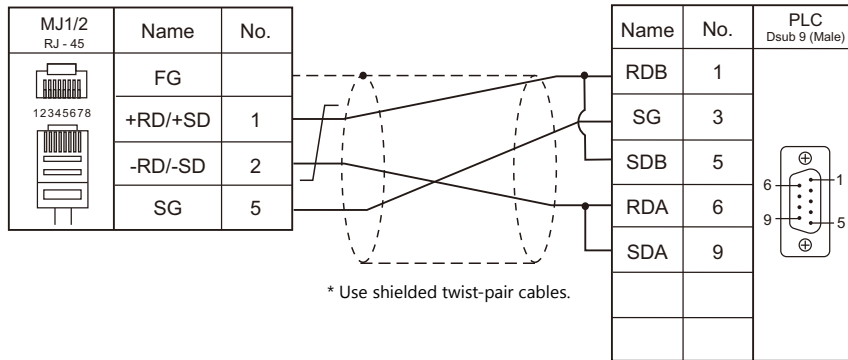

MEMO

Please use this page freely.

14. Oriental Motor

14.1 Temperature Controller / Servo / Inverter Connection

14.1 Temperature Controller / Servo / Inverter Connection

Stepping Motor

PLC Selection on the Editor	Model	Port	Signal Level	Connection		Lst File
				CN1	MJ1/MJ2	
High-efficiency AR series (MODBUS RTU)	ARD-KD ARD-AD ARD-CD	CN6 CN7	RS-485	Wiring diagram 1 - C4	Wiring diagram 1 - M4	OM_AR (MODBUS RTU).Lst
CRK series (MODBUS RTU)	CRD503-KD CRD507-KD CRD507H-KD CRD514-KD	CN6 CN7	RS-485	Wiring diagram 1 - C4	Wiring diagram 1 - M4	OM_CRK (MODBUS RTU).Lst

14.1.1 High-efficiency AR Series (MODBUS RTU)

Communication Setting

Editor

Communication setting

(Underlined setting: default)

Item	Setting	Remarks
Connection Mode	1 : 1 / <u>1 : n</u> / Multi-link2 / Multi-link2 (Ethernet) / 1 : n Multi-link2 (Ethernet)	
Signal Level	<u>RS-422/485</u>	
Baud Rate	9600 / 19200 / 38400 / 57600 / <u>115K</u> bps	
Data Length	<u>8</u> bits	
Stop Bit	<u>1</u> / 2 bits	
Parity	None / Odd / <u>Even</u>	
Target Port No.	0 to 31	0: Broadcast

Stepping Motor

ARD-AD/ARD-CD

MEXE02 (application software)

Setting changes will take effect after turning the power off and back on. If changes are made to any settings, turn the power off and on again.

(Underlined setting: default)

Item	Setting	Remarks
Communication timeout	<u>0</u> to 10000 ms	0: No check * If the V series performs no communication for a set timeout period (other than "0"), an alarm occurs at the stepping motor.
Parity	None / <u>Even</u> / Odd	
Stop bit	<u>1</u> / 2 bits	

Baud rate setting switch (SW2)

SW2	Setting Item	Setting	Remarks
	Baud rate	0: 9600 bps 1: 19200 bps 2: 38400 bps 3: 57600 bps 4: 115200 bps	5 to F disabled

Function setting switches (SW4)

SW4	No.	Setting Item	Setting	Remarks
	1	Device number setting	OFF: 1 to 15 ON: 16 to 31	Use this switch together with the device number setting switch (ID).
	2	Protocol setting	ON: MODBUS protocol	

Device number setting switch (ID)

ID	Setting Item	Setting			Remarks
	Device number	Device No.	Device Number Setting Switch (ID)	Function Setting Switch (SW4) No. 1	Use this switch together with function setting switch (SW4) No. 1. * Do not use device No. 0.
		1 to 15	1 to F	OFF	
		16 to 31	0 to F	ON	

Terminating resistance setting switches (TERM.)

TERM.	Setting Item	Setting	Remarks
	Terminating resistance	Both ON: With terminating resistance Both OFF: Without terminating resistance	Be sure to set both switches to the same position (ON or OFF). Turning ON either one only may result in communication error.

ARD-KD**MEXE02 (application software)**

Setting changes will take effect after turning the power off and back on. If changes are made to any settings, turn the power off and on again.

(Underlined setting: default)

Item	Setting	Remarks
Communication timeout*	<u>0</u> to 10000 ms	0: No check * If the V series performs no communication for a set timeout period (other than "0"), an alarm occurs at the stepping motor.
Parity	None / <u>Even</u> / Odd	
Stop bit	<u>1</u> / 2 bits	

Device number setting switch (SW1)

SW1	Setting Item	Setting	Remarks									
	Device number	<table border="1"> <thead> <tr> <th>Device No.</th> <th>Device Number Setting Switch (ID)</th> <th>Function Setting Switch (SW3) No. 1</th> </tr> </thead> <tbody> <tr> <td>1 to 15</td> <td>1 to F</td> <td>OFF</td> </tr> <tr> <td>16 to 31</td> <td>0 to F</td> <td>ON</td> </tr> </tbody> </table>	Device No.	Device Number Setting Switch (ID)	Function Setting Switch (SW3) No. 1	1 to 15	1 to F	OFF	16 to 31	0 to F	ON	Use this switch together with function setting switch (SW3) No. 1. * Do not use device No. 0.
Device No.	Device Number Setting Switch (ID)	Function Setting Switch (SW3) No. 1										
1 to 15	1 to F	OFF										
16 to 31	0 to F	ON										

Baud rate setting switch (SW2)

SW2	Setting Item	Setting	Remarks
	Baud rate	0: 9600 bps 1: 19200 bps 2: 38400 bps 3: 57600 bps 4: 115200 bps	5 to F disabled

Function setting switches (SW3)

SW3	No.	Setting Item	Setting	Remarks
	1	Device number setting	OFF: 1 to 15 ON: 16 to 31	Use this switch together with the device number setting switch (SW1).
	2	Protocol setting	ON: MODBUS protocol	
	3	Not used	OFF	
	4	Terminating resistance	ON: With terminating resistance OFF: Without terminating resistance	

Available Device Memory

The available setting range of device memory varies depending on the model. Be sure to set within the range available for the model to be used. Use [TYPE] when assigning indirect device memory for macro programs.

Device Memory	TYPE	Remarks
4 (holding register)	02H	

14.1.2 CRK Series (MODBUS RTU)

Communication Setting

Editor

Communication setting

(Underlined setting: default)

Item	Setting	Remarks
Connection Mode	1 : 1 / <u>1:n</u> / Multi-link2 / Multi-link2 (Ethernet) / 1 : n Multi-link2 (Ethernet)	
Signal Level	<u>RS-422/485</u>	
Baud Rate	9600 / 19200 / 38400 / 57600 / <u>115K</u> bps	
Data Length	<u>8 bits</u>	
Stop Bit	<u>1</u> / 2 bits	
Parity	None / Odd / <u>Even</u>	
Target Port No.	0 to 31	0: Broadcast

Stepping Motor

MEXE02 (application software)

Setting changes will take effect after turning the power off and back on. If changes are made to any settings, turn the power off and on again.

(Underlined setting: default)

Item	Setting	Remarks
Communication device number	1 to 31	This setting is valid, provided that the device number setting switch (SW1) is set to "F". * Do not use device No. 0.
Communication protocol	<u>Modbus RTU</u>	
Parity	None / <u>Even</u> / Odd	
Stop bit	<u>1</u> / 2 bits	
Communication timeout	<u>0</u> to 10000 ms	0: No check * If the V series performs no communication for a set timeout period (other than "0"), an alarm occurs at the stepping motor.

Device number setting switch (SW1)

SW1	Setting Item	Setting	Remarks
	Device number	1 to E: 1 to 14	Do not use device No. 0.
		F: Device number of the communication device number parameter in MEXE02	

Function setting switches (SW2)

SW2	No.	Setting Item	Setting	Remarks																								
	1	Baud rate	<table border="1"> <thead> <tr> <th></th> <th>No. 1</th> <th>No. 2</th> <th>No. 3</th> </tr> </thead> <tbody> <tr> <td>9600 bps</td> <td>OFF</td> <td>OFF</td> <td>OFF</td> </tr> <tr> <td>19200 bps</td> <td>ON</td> <td>OFF</td> <td>OFF</td> </tr> <tr> <td>38400 bps</td> <td>OFF</td> <td>ON</td> <td>OFF</td> </tr> <tr> <td>57600 bps</td> <td>ON</td> <td>ON</td> <td>OFF</td> </tr> <tr> <td>115200 bps</td> <td>OFF</td> <td>OFF</td> <td>ON</td> </tr> </tbody> </table>		No. 1	No. 2	No. 3	9600 bps	OFF	OFF	OFF	19200 bps	ON	OFF	OFF	38400 bps	OFF	ON	OFF	57600 bps	ON	ON	OFF	115200 bps	OFF	OFF	ON	
			No. 1	No. 2	No. 3																							
	9600 bps		OFF	OFF	OFF																							
	19200 bps		ON	OFF	OFF																							
38400 bps	OFF	ON	OFF																									
57600 bps	ON	ON	OFF																									
115200 bps	OFF	OFF	ON																									
2																												
3																												
4	Connected device	ON: Universal master device																										

Terminating resistance setting switch (SW3)

SW3	Setting Item	Setting	Remarks
	Terminating resistance	ON: With terminating resistance OFF: Without terminating resistance	

Available Device Memory

The available setting range of device memory varies depending on the model. Be sure to set within the range available for the model to be used. Use [TYPE] when assigning indirect device memory for macro programs.

Device Memory	TYPE	Remarks
4 (holding register)	02H	

14.1.3 Wiring diagram

When Connected at CN1:

RS-485

Wiring diagram 1 - C4

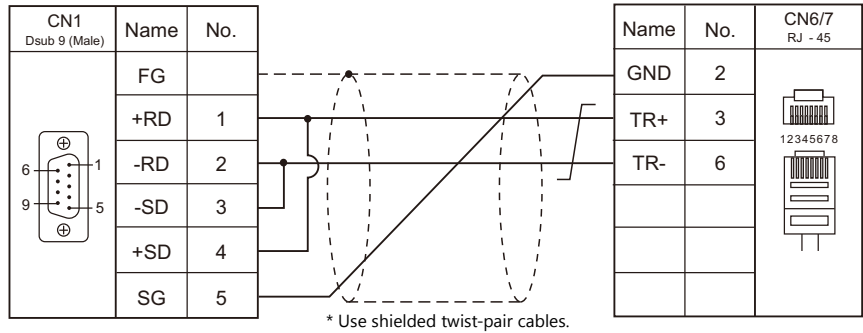

When Connected at MJ1/MJ2:

RS-485

Wiring diagram 1 - M4

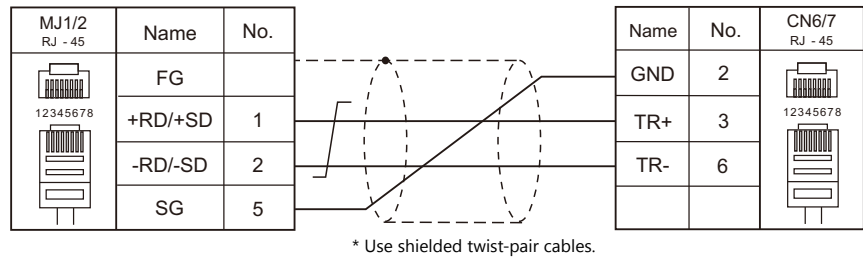

15. Panasonic

- 15.1 PLC Connection
- 15.2 Temperature Controller/Servo/Inverter Connection

15.1 PLC Connection

Serial Connection

PLC Selection on the Editor	CPU	Unit/Port	Signal Level	Connection		Ladder Transfer *1	
				CN1	MJ1/MJ2		
FP Series (RS232C/422)	FP1	COM port of the CPU	RS-232C	Wiring diagram 1 - C2	Wiring diagram 1 - M2	×	
	FP3	AFP3462 (CCU)	RS-232C				
		AFP3463 (C-NET)	RS-422	Wiring diagram 1 - C4	Wiring diagram 1 - M4		
	FP5	AFP5462 (CCU)	RS-232C	Wiring diagram 1 - C2	Wiring diagram 1 - M2		
	FP10	COM port of the CPU	RS-232C				
		AFP5462 (CCU)	RS-232C				
	FP10S FP10SH	COM port of the CPU	RS-232C	Wiring diagram 1 - C4	Wiring diagram 1 - M4		
		AFP3462 (CCU)	RS-232C				
		AFP3463 (C-NET)	RS-422				
	FP0	Tool port of the CPU	RS-232C	Panasonic's "AFC8503" + Gender changer *2	Panasonic's "AFC8503" + Wiring diagram 6 - M2		○
		COM port of the CPU	RS-232C	Wiring diagram 3 - C2	Wiring diagram 3 - M2	×	
	FP2 FP2SH	Tool port of the CPU	RS-232C	Panasonic's "AFC8503" + Gender changer *2	Panasonic's "AFC8503" + Wiring diagram 6 - M2	○	
		COM port of the CPU	RS-232C	Wiring diagram 2 - C2	Wiring diagram 2 - M2	×	
	FPΣ	Tool port of the CPU	RS-232C	Panasonic's "AFC8503" + Gender changer *2	Panasonic's "AFC8503" + Wiring diagram 6 - M2	○	
		AFP801	COM1	RS-232C	Wiring diagram 4 - C2	×	
		AFP802	COM1, C2	RS-232C	Wiring diagram 5 - C2		
		AFP803	COM1	RS-485	Wiring diagram 2 - C4		
		AFP806	COM1	RS-485	Wiring diagram 1 - C4		Wiring diagram 1 - M4
			COM2	RS-232C	Wiring diagram 3 - C2		Wiring diagram 3 - M2
	FP-e	Tool port of the CPU	RS-232C	Panasonic's "AFC8503" + Gender changer *2	Panasonic's "AFC8503" + Wiring diagram 6 - M2		○
COM port of the CPU		RS-232C	Wiring diagram 3 - C2	Wiring diagram 3 - M2	×		
	RS-485	Wiring diagram 2 - C4	Wiring diagram 2 - M4				
FP-X	Tool port of the CPU	RS-232C	Panasonic's "AFC8503" + Gender changer *2	Panasonic's "AFC8503" + Wiring diagram 6 - M2	○		
	AFPX-COM1	COM1	RS-232C	Wiring diagram 4 - C2	×		
	AFPX-COM2	COM1, C2	RS-232C	Wiring diagram 5 - C2			
	AFPX-COM3	COM1	RS-485	Wiring diagram 1 - C4		Wiring diagram 1 - M4	
	AFPX-COM4	COM1	RS-485				
		COM2	RS-232C	Wiring diagram 3 - C2		Wiring diagram 3 - M2	
FP7 Series (RS232C/422)	FP7	COM0 of the CPU	RS-232	Wiring diagram 3 - C2		Wiring diagram 3 - M2	
		AFP7CCS1			CH1		
		AFP7CCS2			CH1, CH2		
		AFP7CCM1	CH1	RS-485	Wiring diagram 1 - C4	Wiring diagram 1 - M4	
		AFP7CCM2	CH1, CH2				
		AFP7CCS1M1	CH1	RS-232	Wiring diagram 3 - C2	Wiring diagram 3 - M2	
			CH2				

*1 For the ladder transfer function, see the V9 Series Reference Manual.

*2 Use a D-sub gender changer (9-pin, female-to-male) commercially available.

Manufacturer	Model
Black Box	FA440-R2
Misumi	DGC-9PP

Ethernet Connection

FP/FP-X Series

PLC Selection on the Editor	CPU	Unit	TCP/IP	UDP/IP	Port No.	Keep Alive ^{*5}	Ladder Transfer ^{*6}
FP Series (TCP/IP) ^{*1}	FP2	FP2-ET1	○	×	As desired ^{*2}	○	×
FP Series (UDP/IP)			×	○			×
FP-X (TCP/IP)	FP-X	AFPX-COM5	○	×	As desired ^{*3}		×
FP7 Series (Ethernet)	FP7	Built-in Ethernet	○	○	8000 to 65535 ^{*4}		×

^{*1} To speed up communications, we recommend you to use UDP/IP communication.

^{*2} Eight connection settings are provided on the PLC; each for one V9 unit. Therefore, a maximum of eight V9 units can be connected to an Ethernet unit.

^{*3} A maximum of three units can be connected to one port by setting the "Source Port No." on the PLC communication tool. Therefore, a maximum of three V9 units can be connected to an Ethernet unit.

^{*4} A maximum of 16 V9 units can be connected.

^{*5} For KeepAlive functions, see "1.3.2 Ethernet Communication".

^{*6} For the ladder transfer function, see the V9 Series Reference Manual.

15.1.1 FP Series (RS232C/422)

Communication Setting

Editor

Communication setting

(Underlined setting: default)

Item	Setting	Remarks
Connection Mode	<u>1</u> : <u>1</u> / 1 : n / Multi-link / Multi-link2 / Multi-link2 (Ethernet) / 1 : n Multi-link2 (Ethernet)	
Signal Level	<u>RS-232C</u> / RS-422/485	
Baud Rate	4800 / 9600 / <u>19200</u> / 38400 / 57600 / 115k bps	
Data Length	7 / <u>8</u> bits	
Stop Bit	<u>1</u> / 2 bits	
Parity	None / <u>Odd</u> / Even	
Target Port No.	0 to 31	
Header	% (<u>Header</u>) / < (Extension Header)	Models on which "< (Extension header)" is available: FP2, FP2SH, FPΣ, FP-X, FP0R
Monitor Registration	Unchecked / <u>Checked</u>	One V9 unit can be registered as a monitor for one PLC. When multi-link connection (n : 1) is selected, do not check this box for multiple V9 units.

PLC

Be sure to match the settings to those made under [Communication Setting] of the editor.

FP-X

Tool port setting

(Underlined setting: default)

System Register *1	Contents	
410	Unit No.	<u>1</u> to 99
412	Communication Mode	Computer link
413	Data Length	7 / <u>8</u> bits
	Parity	None / <u>Odd</u> / Even
	Stop Bit	<u>1</u> / 2 bits
415	Baud Rate	4800 / <u>9600</u> / 19200 / 38400 / 57600 / 115k bps

*1 System register setting is enabled in the RUN mode.

COM port setting

(Underlined setting: default)

System Register *1		Contents	
COM1	COM2		
410	411	Unit No.	<u>1</u> to 99
412		Operation Mode	Computer link
413	414	Data Length	7 / <u>8</u> bits
		Parity	None / <u>Odd</u> / Even
		Stop Bit	<u>1</u> / 2 bits
415		Baud Rate	4800 / <u>9600</u> / 19200 / 38400 / 57600 / 115k bps *2

*1 System register setting is enabled in the RUN mode.

*2 For AFPX COM3, set the switch attached to the back of the cassette as well.
SW1 to 3: ON (RS-485), SW4: ON (terminator ON)

*3 Some restrictions may apply to the communication cassette when the USB port is used on the CPU. For more information, refer to the PLC manual issued by the manufacturer.

FP-Σ

Tool port setting

(Underlined setting: default)

System Register *1	Contents	
410	Unit No.	<u>1</u> to 99
413	Data Length	7 / <u>8</u> bits
	Parity	None / <u>Odd</u> / Even
	Stop Bit	<u>1</u> / 2 bits
415	Baud Rate	4800 / <u>9600</u> / 19200 / 38400 / 57600 / 115k bps

*1 System register setting is enabled in the RUN mode.

COM port setting

(Underlined setting: default)

System Register *1		Contents	
COM1	COM2		
410	411	Unit No.	<u>1</u> to 99*3
412		Communication Mode	Computer link
413	414	Data Length	7 / <u>8</u> bits
		Parity	None / <u>Odd</u> / Even
		Stop Bit	<u>1</u> / 2 bits
415		Baud Rate	4800 / <u>9600</u> / 19200 / 38400 / 57600 / 115k bps *2

*1 System register setting is enabled in the RUN mode.

*2 For AFP806COM1, set the switch attached to the back of the cassette as well.
SW1 to 2: OFF 19200 bps, ON 115 kbps

*3 In addition to system register setting, the station number setting is also possible with the station number setting switch. For more information, refer to the PLC manual issued by the manufacturer.

FP1 / FP0 / FP-e

Tool port setting

(Underlined setting: default)

System Register *1	Contents	
411	Data Length	7 / <u>8</u> bits
414	Baud Rate	<u>9600</u> / 19200
-	Parity	Odd (fixed)
-	Stop Bit	1 (fixed)

*1 System register setting is enabled in the RUN mode.

COM port setting

(Underlined setting: default)

System Register *1	Contents	
412	Communication Mode	Computer link
413	Data Length	7 / <u>8</u> bits
	Parity	None / <u>Odd</u> / Even
	Stop Bit	<u>1</u> / 2 bits
414	Baud Rate	4800 / <u>9600</u> / 19200
415	Unit No.	<u>1</u> to 99

*1 System register setting is enabled in the RUN mode.

FP2**Tool port setting**

(Underlined setting: default)

System Register * ¹	Contents	
411	Data Length	7 / <u>8</u> bits
414	Baud Rate * ²	4800 / 9600 / <u>19200</u> / 38400 / 57600 / 115200 bps
-	Parity	Odd (fixed)
-	Stop Bit	1 (fixed)

*1 System register setting is enabled in the RUN mode.

*2 Enabled when the DIP switch 1 on the back of the CPU unit is set to the OFF position.

COM port setting

(Underlined setting: default)

System Register * ¹	Contents	
412	Communication Mode	Computer link
413	Data Length	7 / <u>8</u> bits
	Parity	None / <u>Odd</u> / Even
	Stop Bit	<u>1</u> / 2 bits
414	Baud Rate	4800 / 9600 / <u>19200</u> / 38400 / 57600 / 115200 bps
415	Unit No.	<u>1</u> to 99

*1 System register setting is enabled in the RUN mode.

FP10/FP10s (COM Port)**Operation mode setting switch**

Switch	Setting	Contents
4	OFF	Baud rate: 19200 bps
5	ON	Data length: 8 bits
6	ON	With parity
7	OFF	Odd
8	OFF	Stop bit 1

Station number setting switch

(Underlined setting: default)

Switch		Setting
The tens place	The ones place	<u>01</u> to 32

FP10SH (COM Port)**Operation mode setting switch (upper)**

Switch	Setting	Contents
1	OFF	Not control with a modem
2	OFF	Beginning code STX invalid
3	OFF	Terminating code CR
4	ON	
5	ON	Stop bit 1
6	ON	Odd parity
7	ON	
8	ON	Data length: 8 bits

Operation mode setting switch (lower)

Switch	Setting	Contents
6	ON	Baud rate: 19200 bps
7	ON	
8	OFF	

Station number setting switch (lower)

(Underlined setting: default)

Switch		Setting
The tens place	The ones place	<u>0</u> 1 to 32

AFP3462 / AFP5462 (CCU)**DIP switch setting**

Switch	Setting	Contents
1	ON	Baud rate: 19200 bps
2	OFF	
3	OFF	
4	ON	Data length: 8 bits
5	ON	With parity
6	OFF	Odd
7	OFF	Stop bit 1
8	OFF	CS, CD invalid

AFP3463 (C-NET Link Unit)**DIP switch setting**

Switch	Setting	Contents
1	OFF	Baud rate: 19200 bps
2	ON	Data length: 8 bits
3	ON	With parity
4	OFF	Odd
5	OFF	Stop bit 1
6	OFF	-
7	OFF	-
8	OFF	-

Available Device Memory

The available setting range of device memory varies depending on the PLC model. Be sure to set within the range available for the PLC to be used. Use [TYPE] when assigning indirect device memory for macro programs.

Device Memory	TYPE	Remarks
DT (data register)	00H	
X (external input)	01H	WX as word device, read only
Y (external output)	02H	WY as word device
R (internal relay)	03H	WR as word device, including special relays
L (link relay)	04H	WL as word device
LD (link register)	05H	
FL (file register)	06H	FP2, 3, 5, 10 only
SV (timer, counter/set value)	07H	
EV (timer, counter/elapsed time)	08H	
T (timer/contact)	09H	Read only
C (counter/contact)	0AH	Read only

15.1.2 FP Series (TCP/IP)

Communication Setting

Editor

Make the following settings on the editor. For more information, see "1.3.2 Ethernet Communication".

- IP address for the V9 unit
 - When specified on the screen program:
[System Setting] → [Hardware Setting] → [Local Port IP Address]
 - When specified on the V9 unit:
Local mode → [LAN Setting]
- Port number for the V9 unit (for communication with PLC)
[System Setting] → [Hardware Setting] → [PLC Properties] → [Communication Setting]
- Others
[System Setting] → [Hardware Setting] → [PLC Properties] → [Communication Setting]

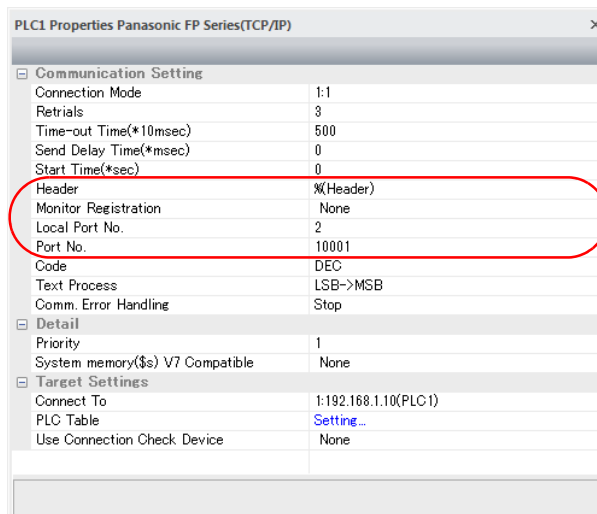

Item	Contents
Header	Select a format of communication with the PLC. % (Header) / < (Extension Header)
Monitor Registration	Select [Yes] in the case where a monitor registration command is used for communication with the PLC. * One V9 unit can be registered as a monitor for one PLC. Do not select [Yes] for multiple V9 units in n : 1 connection.
Local Port No.	Set the local port number of the V9 unit (1 to 31). Set the same number as the one set for "Target node MEWTOCOL station number" on the [Connection Setting] dialog of the PLC.

* For settings other than the above, see "1.4 Hardware Settings".

- IP address and port number of the PLC
 Register on the [PLC Table] in [System Setting] → [Hardware Setting] → [PLC Properties] → [Target Settings].
 Set the same PLC table number as the one set for "MEWTOCOL Station Number" ([Initial Information Setting] → [Local Node Setting]).

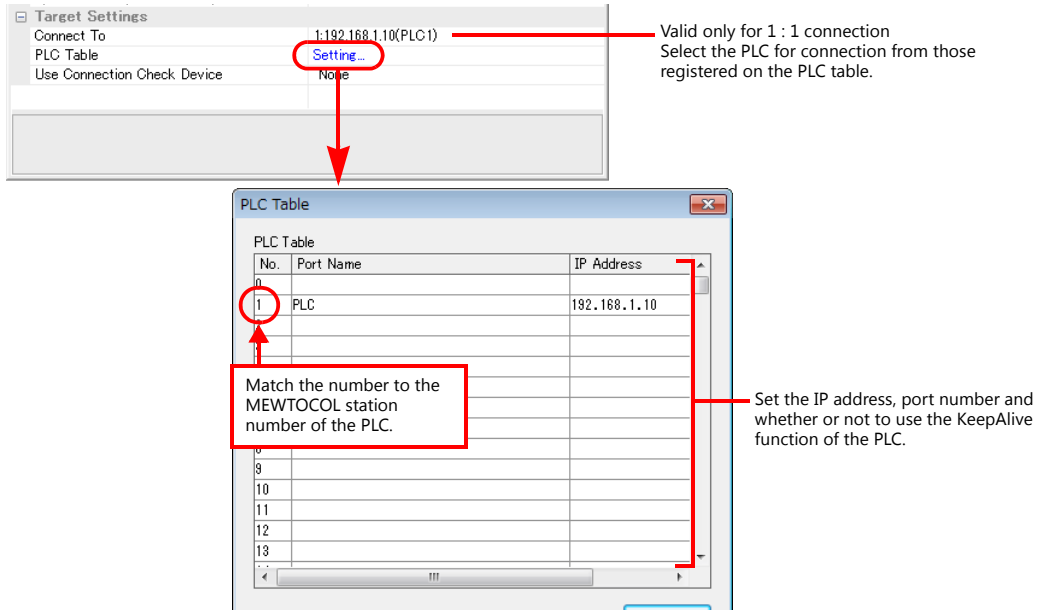

PLC

Make the mode setting using the Ethernet unit "FP2-ET1".

Mode setting switch

Switch	Setting	Contents	Remarks
2	ON	Auto connection function	

Make the PLC setting using the configuration tool "Configurator ET". For more information, refer to the PLC manual issued by the manufacturer.

Initial information setting

	Item	Setting
Local Node Setting	IP Address	IP address of the PLC
	MEWTOCOL Station Number	1 to 31 * The same number must be specified for the PLC table number of the V9.

Connection setting

	Item	Setting
Connection 1 to 8 * Select a port to which the V9 is connected.	Communication Mode	TCP/IP
	Open Type	Unpassive
	Usage	MEWTOCOL communication
	Local Node (PLC) Port Number	As desired
	Target Node IP Address	IP address of the V9
	Target Node Port Number	Port number of the V9
	Target Node MEWTOCOL Station Number	1 to 31 * Match the number to the one set for [Local Port No.] under [Communication Setting] on the V9.
	Connection Setting	Valid

Available Device Memory

The available setting range of device memory varies depending on the PLC model. Be sure to set within the range available for the PLC to be used. Use [TYPE] when assigning indirect device memory for macro programs.

Device Memory	TYPE	Remarks
DT (data register)	00H	
X (external input)	01H	WX as word device, read only
Y (external output)	02H	WY as word device
R (internal relay)	03H	WR as word device, including special relays
L (link relay)	04H	WL as word device
LD (link register)	05H	
FL (file register)	06H	FP2, 3, 5, 10 only
SV (timer, counter/set value)	07H	
EV (timer, counter/elapsed time)	08H	
T (timer/contact)	09H	Read only
C (counter/contact)	0AH	Read only

15.1.3 FP Series (UDP/IP)

Communication Setting

Editor

Make the following settings on the editor. For more information, see "1.3.2 Ethernet Communication".

- IP address for the V9 unit
 - When specified on the screen program:
[System Setting] → [Hardware Setting] → [Local Port IP Address]
 - When specified on the V9 unit:
Local mode → [LAN Setting]
- Port number for the V9 unit (for communication with PLC)
[System Setting] → [Hardware Setting] → [PLC Properties] → [Communication Setting]
- Others
[System Setting] → [Hardware Setting] → [PLC Properties] → [Communication Setting]

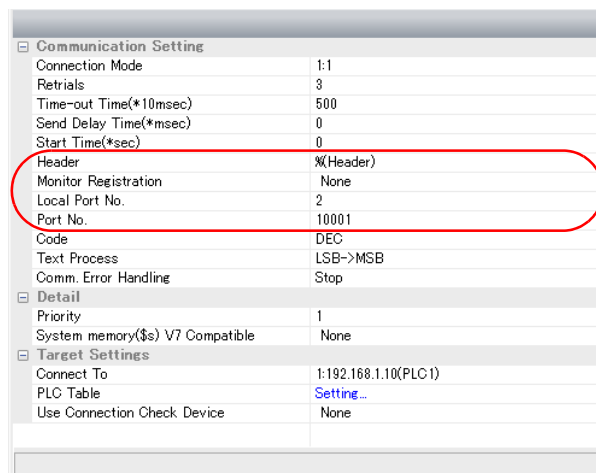

Item	Contents
Header	Select a format of communication with the PLC. % (Header) / < (Extension Header)
Monitor Registration	Select [Yes] in the case where a monitor registration command is used for communication with the PLC. * One V9 unit can be registered as a monitor for one PLC. Do not select [Yes] for multiple V9 units in n : 1 connection.
Local Port No.	Set the local port number of the V9 unit (1 to 31). Set the same number as the one set for "Target node MEWTOCOL station number" on the [Connection Setting] dialog of the PLC.

* For settings other than the above, see "1.4 Hardware Settings".

- IP address and port number of the PLC
 Register on the [PLC Table] in [System Setting] → [Hardware Setting] → [PLC Properties] → [Target Settings].
 Set the same PLC table number as the one set for "MEWTOCOL Station Number" ([Initial Information Setting] → [Local Node Setting]).

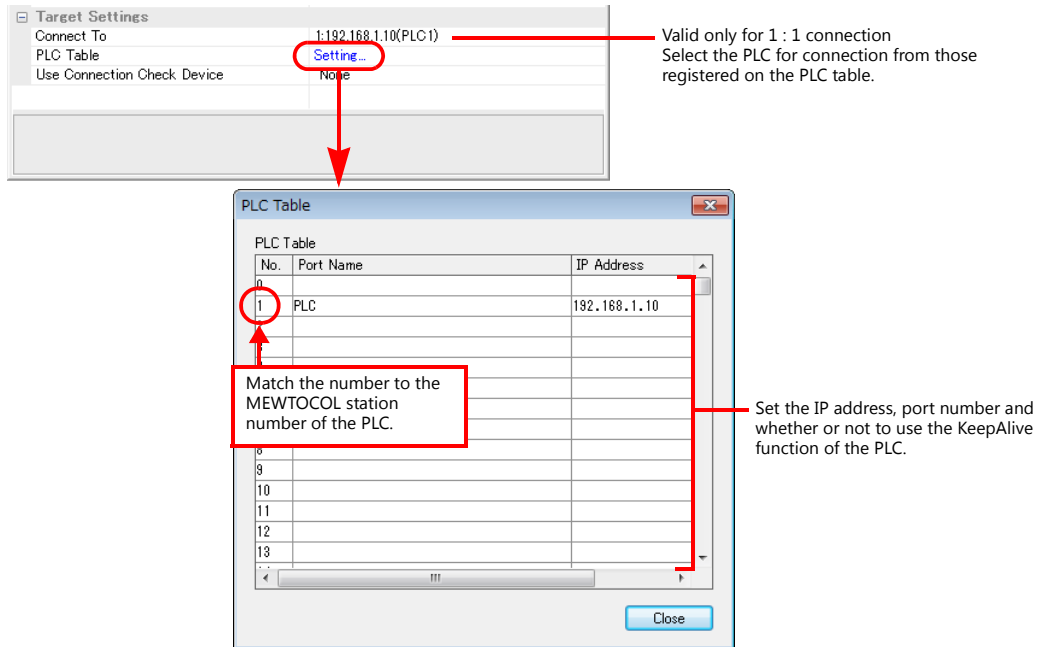

PLC

Make the mode setting using the Ethernet unit "FP2-ET1".

Mode setting switch

Switch	Setting	Contents	Remarks
2	ON	Auto connection function	

Make the PLC setting using the configuration tool "Configurator ET". For more information, refer to the PLC manual issued by the manufacturer.

Initial information setting

Item		Setting
Local Node Setting	IP Address	IP address of the PLC
	MEWTOCOL Station Number	1 to 31 * The same number must be specified for the PLC table number of the V9.

Connection setting

Item		Setting
Connection 1 to 8 * Select a port to which the V9 is connected.	Communication Mode	UDP/IP
	Open Type	Unpassive
	Usage	MEWTOCOL communication
	Local Node (PLC) Port Number	As desired
	Target Node IP Address	IP address of the V9
	Target Node Port Number	Port number of the V9
	Target Node MEWTOCOL Station Number	1 to 31 * Match the number to the one set for [Local Port No.] under [Communication Setting] on the V9.
	Connection Setting	Valid

Available Device Memory

The available setting range of device memory varies depending on the PLC model. Be sure to set within the range available for the PLC to be used. Use [TYPE] when assigning indirect device memory for macro programs.

Device Memory	TYPE	Remarks
DT (data register)	00H	
X (external input)	01H	WX as word device, read only
Y (external output)	02H	WY as word device
R (internal relay)	03H	WR as word device, including special relays
L (link relay)	04H	WL as word device
LD (link register)	05H	
FL (file register)	06H	FP2, 3, 5, 10 only
SV (timer, counter/set value)	07H	
EV (timer, counter/elapsed time)	08H	
T (timer/contact)	09H	Read only
C (counter/contact)	0AH	Read only

15.1.4 FP-X (TCP/IP)

Communication Setting

Editor

Make the following settings on the editor. For more information, see "1.3.2 Ethernet Communication".

- IP address for the V9 unit
 - When specified on the screen program:
[System Setting] → [Hardware Setting] → [Local Port IP Address]
 - When specified on the V9 unit:
Local mode → [LAN Setting]
- Port number for the V9 unit (for communication with PLC)
[System Setting] → [Hardware Setting] → [PLC Properties] → [Communication Setting]
- Others
[System Setting] → [Hardware Setting] → [PLC Properties] → [Communication Setting]

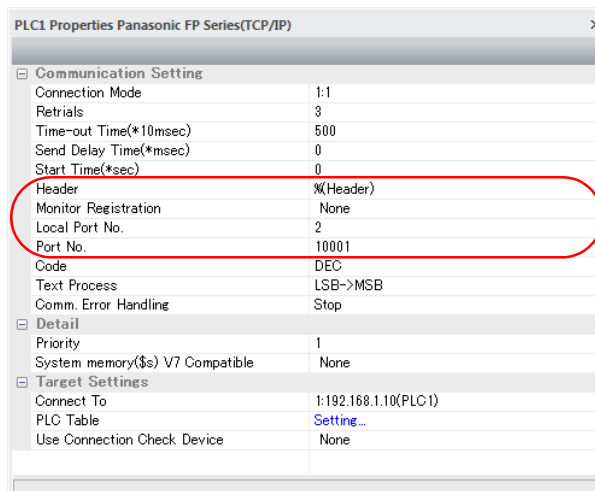

Item	Contents
Header	Select a format of communication with the PLC. % (Header) / < (Extension Header)
Monitor Registration	Select [Yes] in the case where a monitor registration command is used for communication with the PLC. * One V9 unit can be registered as a monitor for one PLC. Do not select [Yes] for multiple V9 units in n : 1 connection.

* For settings other than the above, see "1.4 Hardware Settings".

- IP address and port number of the PLC
 Register on the [PLC Table] in [System Setting] → [Hardware Setting] → [PLC Properties] → [Target Settings].
 Set the same PLC table number as the one set for "No. 410 Unit No." ([Option] → [PLC System Register Setting] → [COM1 Port Setting]).

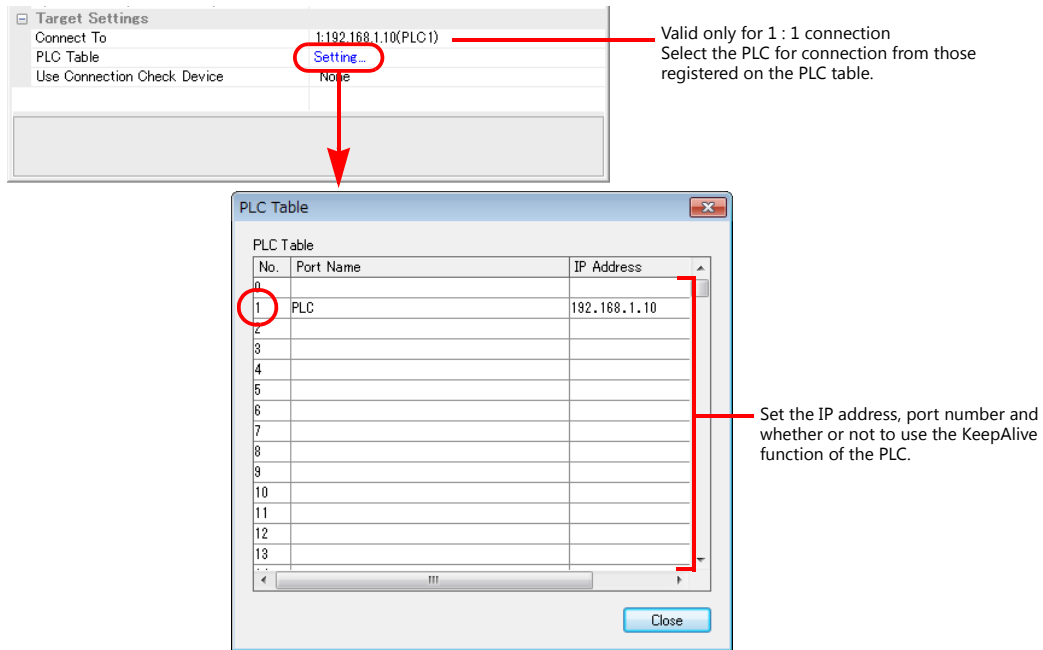

PLC

Make the PLC setting using the communication tool "Configurator WD" and the programming tool "FPWIN GR". For more information, refer to the PLC manual issued by the manufacturer.

IP address setting (Configurator WD)

Item		Setting
Basic Setting	Unit Name	Unit name of the communication cassette "AFPX-COM5"
	IP Address	IP address of the PLC
	Subnet mask	Subnet mask of the PLC
	Gateway	Gateway of the PLC

Communication setting (Configurator WD)

Item		Setting
Communication Mode		Computer link
Action Mode		Server mode
Control unit - Communication cassette Setting	Baud rate of COM1 Port	9600 / 115200 bps
Server Setting	Source Port No.	As desired

COM1 port setting (FPWIN GP)

Item		Setting
No. 410	Unit No.	1 to 99 * The same number must be specified for the PLC table number of the V9.
No. 412	Communication Mode	Computer link
No. 413	Communication Format	Data Length 8 bits
		Parity Odd
		Stop Bit 1 bit
No. 415	Baud rate	9600 / 115200 bps * Match the baud rate to the one set for "Baud rate of COM1 Port" in the [Control unit - Communication cassette Setting] of the [Communication Setting] dialog on the communication tool "Configurator WD".

Available Device Memory

The available setting range of device memory varies depending on the PLC model. Be sure to set within the range available for the PLC to be used. Use [TYPE] when assigning indirect device memory for macro programs.

Device Memory	TYPE	Remarks
DT (data register)	00H	
X (external input)	01H	WX as word device, read only
Y (external output)	02H	WY as word device
R (internal relay)	03H	WR as word device, including special relays
L (link relay)	04H	WL as word device
LD (link register)	05H	
FL (file register)	06H	
SV (timer, counter/set value)	07H	
EV (timer, counter/elapsed time)	08H	
T (timer/contact)	09H	Read only
C (counter/contact)	0AH	Read only

15.1.5 FP7 Series (RS232C/422)

Communication Setting

Editor

Communication setting

(Underlined setting: default)

Item	Setting	Remarks
Connection Mode	<u>1:1</u> / 1:n / Multi-link / Multi-link2 / Multi-link2 (Ethernet) / 1:n Multi-link2 (Ethernet)	
Signal Level	<u>RS-232C</u> / RS-422/485	
Baud Rate	4800 / <u>9600</u> / 19200 / 38400 / 57600 / 115K bps	
Data Length	7 / <u>8</u> bits	
Stop Bit	<u>1</u> / 2 bits	
Parity	None / <u>Odd</u> / Even	
Target Port No.	0 to 255	

PLC

FP7 configuration

Make PLC settings using the programming tool "FPWIN GR7".

For more information, refer to the PLC manual issued by the manufacturer.

(Underlined setting: default)

Setting Items		Descriptions
Built-in SCU	COM0 setting	Communication mode
	COM1 setting *1	Target port No.
	COM 2 setting *1	Baud rate
		Data length
		Parity
		Stop bit
		CS/RS
		Transmission latency setting
		Beginning code STX
		Terminating resistance
	Modem initialization	



*1 When using communication cassettes, configure CH1 and CH2 as COM1 and COM2 respectively.

CH1 = COM1
CH2 = COM2

AFP7CCS2

Setting Items	Contents	Remarks
	Signal line change 3W	Set all switches to 3W.

AFP7CCM1/AFP7CCM2

Setting Item	Contents	Remarks
	Signal level change RS-485	Turn on all three switches of the CH for connection.
	Terminating resistance setting ON at termination	

AFP7CCS1M1

Setting Item	Contents	Remarks
	RS-485 Terminating resistance setting	ON at termination

Calendar

This model is equipped with a calendar function; however, the calendar data cannot be written from the V series. Thus, time correction must be performed on the PLC side.

Available Device Memory

The available setting range of device memory varies depending on the PLC model. Be sure to set within the range available for the PLC to be used. Use [TYPE] when assigning indirect device memory for macro programs.

Device Memory	TYPE	Remarks
DT (data register)	00H	*1
X (external input)	01H	WX as word device; X0 to X1F and X70 to X9F: read only *1
Y (external output)	02H	WY as word device; Y0 to Y9, Y13, Y15 to Y1F, Y70 to Y9F: read only *1
R (internal relay)	03H	WR as word device, including special relays *1
L (link relay)	04H	WL as word device *1
LD (link register)	05H	*1
T (timer/contact)	09H	Read only *1
C (counter/contact)	0AH	Read only *1
P (pulse relay)	0BH	Read only *1
E (error report relay)	0CH	Read only
SD (system data)	0DH	Read only
SR (system relay)	0EH	WS as word device, read only
IN (direct input)	0FH	WI as word device, read only *2
OT (direct output)	10H	WO as word device *2
UM (unit memory)	11H	*2
TS (timer/set value)	12H	Double-word *1
TE (timer/elapsed value)	13H	Double-word *1
CS (counter/set value)	14H	Double-word *1
CE (counter/elapsed value)	15H	Double-word *1
I (index register)	16H	Double-word

*1 Specify the program block number. Indications on the screen configuration software are as follows.

PLC1 0:DT0000100

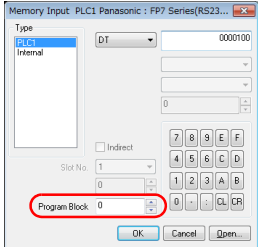

Example: 1: DT000100

- ↑ Address number
- ↑ Device type
- ↑ Program block number
- 0: Global device
- 1 to 999: Local device

*2 Specify the slot number. Indications on the screen configuration software are as follows.

PLC1 1:UM000100

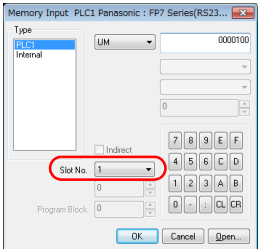

Example: 1: UM000100

- ↑ Address number
- ↑ Device type
- ↑ Slot number: 1 to 99

Indirect device memory designation

n + 0	15	8	7	5	4	0
	Model			Device type		
n + 1	Lower address No.					
n + 2	Program block number			Higher address No.		
n + 3	Expansion code *			Bit designation		
n + 4	00			Station number		

* Specify the expansion code as follows.

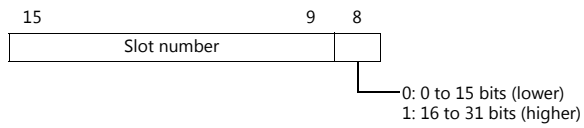

15.1.6 FP7 Series (Ethernet)

Communication Setting

Editor

Make the following settings on the editor. For more information, see "1.3.2 Ethernet Communication".

- IP address for the V9 unit
 - When specified on the screen program:
[System Setting] → [Hardware Setting] → [Local Port IP Address]
 - When specified on the V9 unit:
Local mode → [LAN Setting]
- Port number for the V9 unit (for communication with PLC)
[System Setting] → [Hardware Setting] → [PLC Properties] → [Communication Setting]

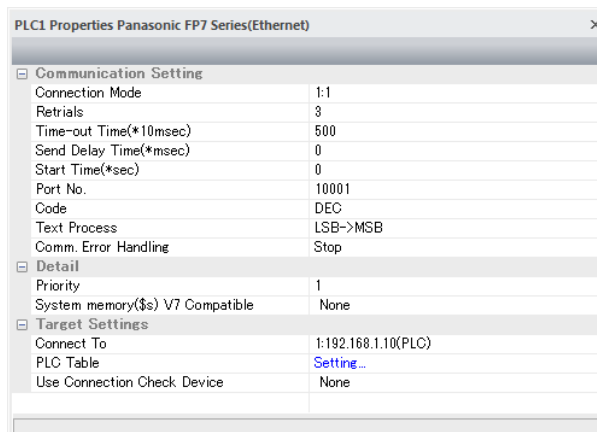

- IP address and port number (No. 8000 to 65535) of the PLC Register on the [PLC Table] in [System Setting] → [Hardware Setting] → [PLC Properties] → [Target Settings].

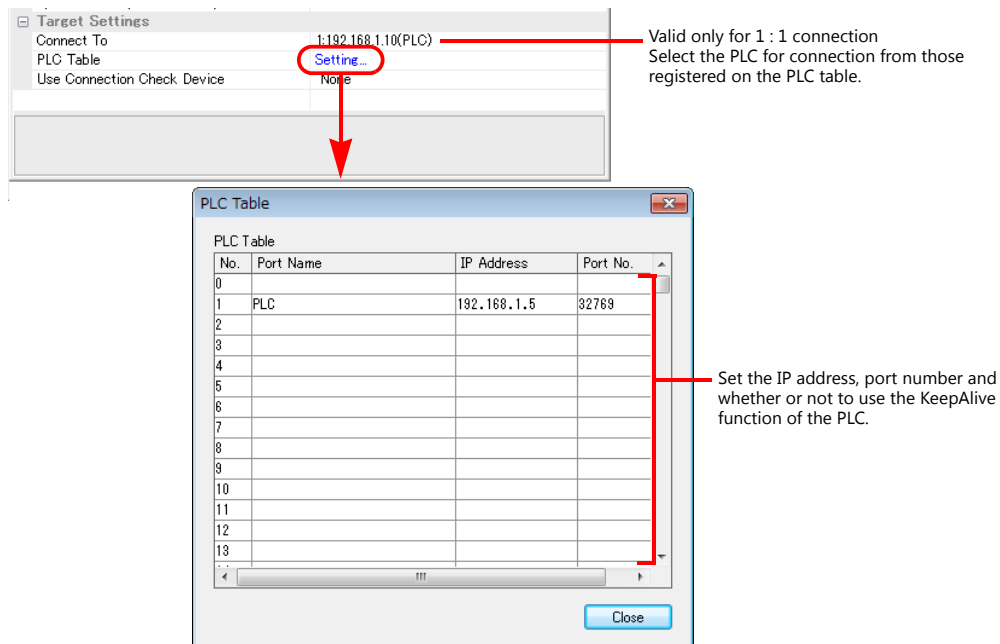

PLC

Make PLC settings using the programming tool "FPWIN GR7".
For more information, refer to the PLC manual issued by the manufacturer.

FP7 configuration

Setting Item		Setting	
Built-in ET-LAN	Basic information on communication	Local IP address	Set the IP address of the PLC.
		Subnet mask	Set the subnet mask of the PLC.
		Default gateway	Set the default gateway of the PLC.
	User connection information settings	Operation mode	MEWTOCOL-7
		Connection usage	Use
		Open system (server/client)	Server connection (target station as desired) / server connection (target station specified)
		Open system (automatic/manual)	Open automatically
		Communication mode	UDP/IP / TCP/IP
		Local port No.	Set the port number of the PLC (8000 to 65535).
		Target port No.	Port number of the V9 (communication mode: TCP/IP, open system (server/client): Not required for server connection (target station as desired))
		Unused connection time	0
		Target port setting method	Specify the IP address (IPv4).
		Target IP address	IP address of the V9 (communication mode: TCP/IP, open system (server/client): Not required for server connection (target station as desired))

Calendar

This model is equipped with a calendar function; however, the calendar data cannot be written from the V series. Thus, time correction must be performed on the PLC side.

Available Device Memory

The available setting range of device memory varies depending on the PLC model. Be sure to set within the range available for the PLC to be used. Use [TYPE] when assigning indirect device memory for macro programs.

Device Memory	TYPE	Remarks
DT (data register)	00H	*1
X (external input)	01H	WX as word device; X0 to X1F and X70 to X9F: read only *1
Y (external output)	02H	WY as word device; Y0 to Y9, Y13, Y15 to Y1F, Y70 to Y9F: read only *1
R (internal relay)	03H	WR as word device, including special relays *1
L (link relay)	04H	WL as word device *1
LD (link register)	05H	*1
T (timer/contact)	09H	Read only *1
C (counter/contact)	0AH	Read only *1
P (pulse relay)	0BH	Read only *1
E (error report relay)	0CH	Read only
SD (system data)	0DH	Read only
SR (system relay)	0EH	WS as word device, read only
IN (direct input)	0FH	WI as word device, read only *2
OT (direct output)	10H	WO as word device *2
UM (unit memory)	11H	*2
TS (timer/set value)	12H	Double-word *1
TE (timer/elapsed value)	13H	Double-word *1
CS (counter/set value)	14H	Double-word *1
CE (counter/elapsed value)	15H	Double-word *1
I (index register)	16H	Double-word

*1 Specify the program block number. Indications on the screen configuration software are as follows.

PLC1 0:DT0000100

Example: 1:DT000100

- └─ Address number
- └─ Device type
- └─ Program block number
- 0: Global device
- 1 to 999: Local device

*2 Specify the slot number. Indications on the screen configuration software are as follows.

PLC1 1:UM000100

Example: 1:UM000100

- └─ Address number
- └─ Device type
- └─ Slot number: 1 to 99

Indirect device memory designation

	15	8	7	5	4	0
n + 0	Model			Device type		
n + 1	Lower address No.					
n + 2	Program block number			Higher address No.		
n + 3	Expansion code *			Bit designation		
n + 4	00			Station number		

* Specify the expansion code as follows.

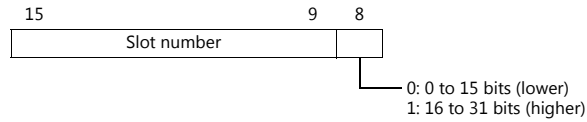

15.1.7 Wiring Diagrams

When Connected at CN1:

RS-232C

Wiring diagram 1 - C2

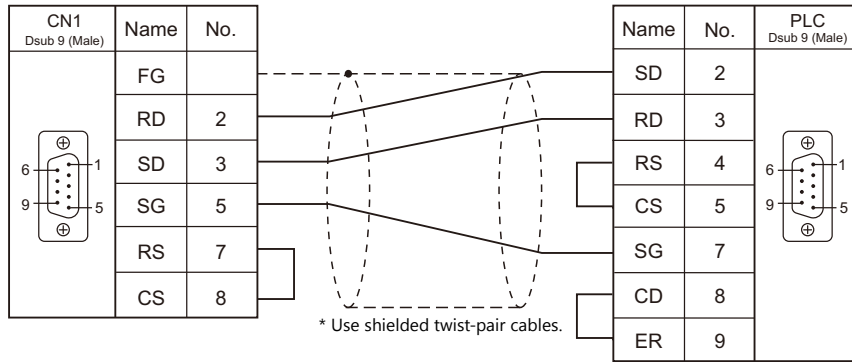

Wiring diagram 2 - C2

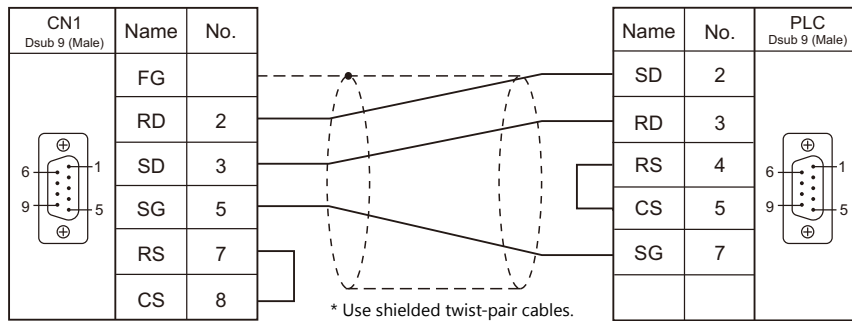

Wiring diagram 3 - C2

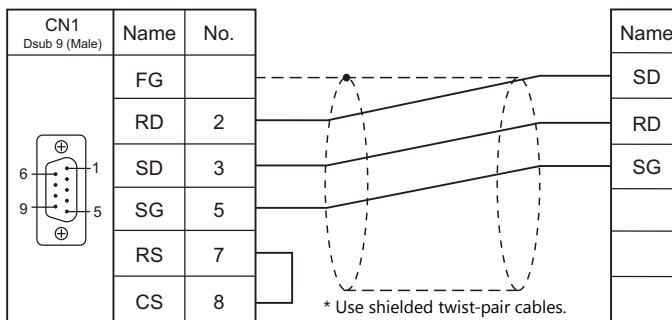

Wiring diagram 4 - C2

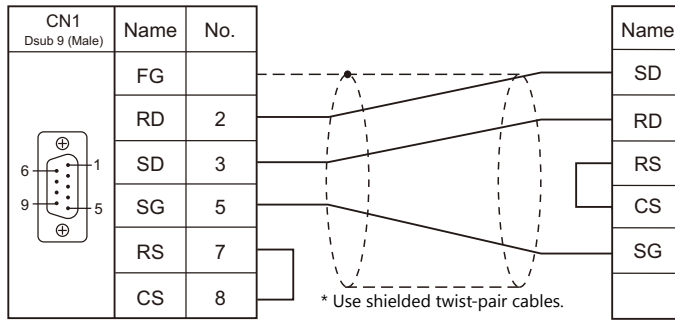

Wiring diagram 5 - C2

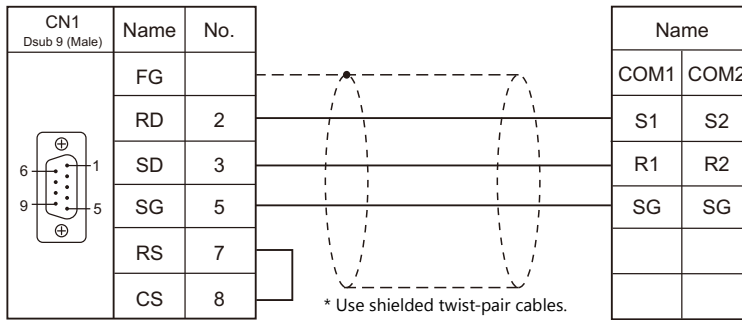

RS-422/RS-485

Wiring diagram 1 - C4

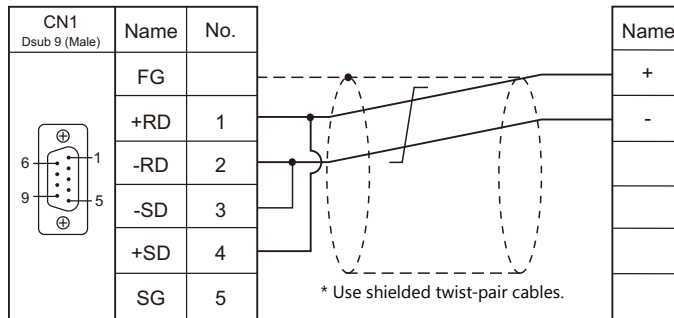

Wiring diagram 2 - C4

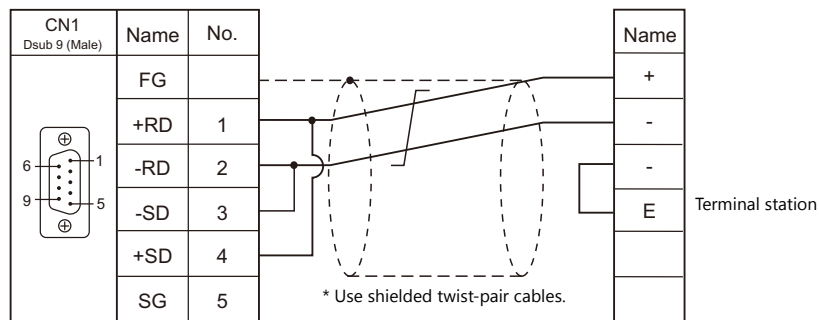

When Connected at MJ1/MJ2:

RS-232C

Wiring diagram 1 - M2

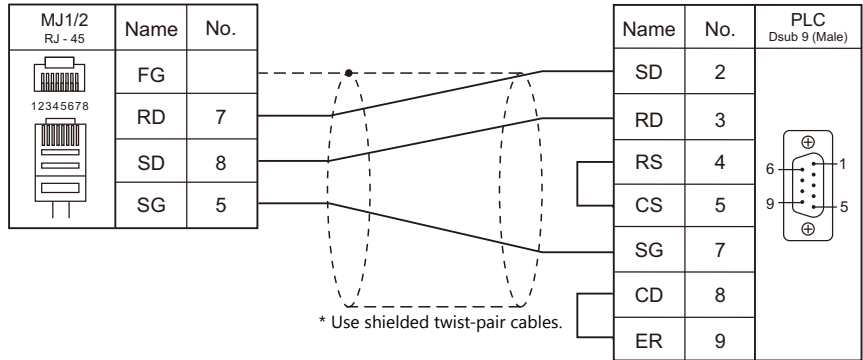

Wiring diagram 2 - M2

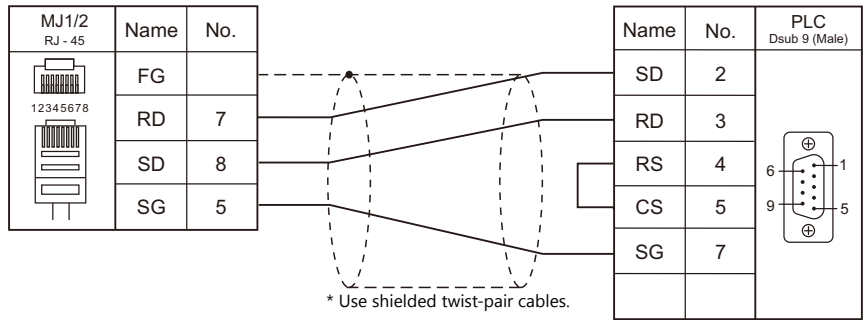

Wiring diagram 3 - M2

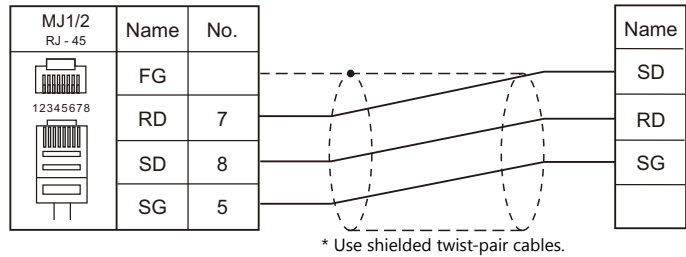

Wiring diagram 4 - M2

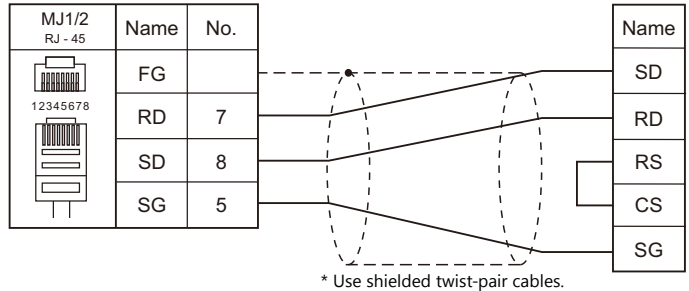

Wiring diagram 5 - M2

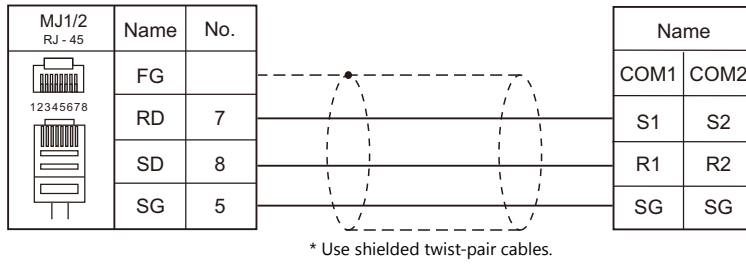

Wiring diagram 6 - M2

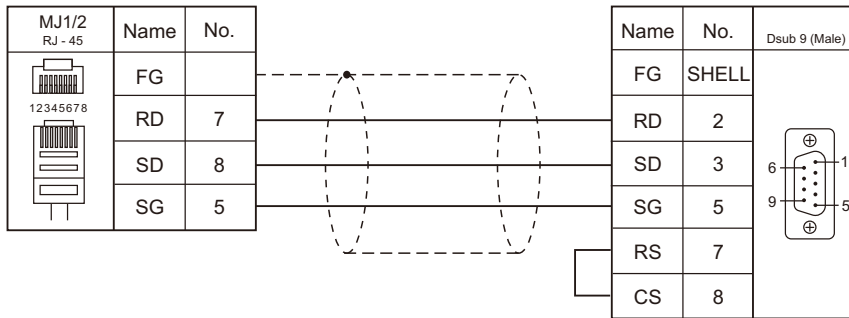

RS-422/RS-485

Wiring diagram 1 - M4

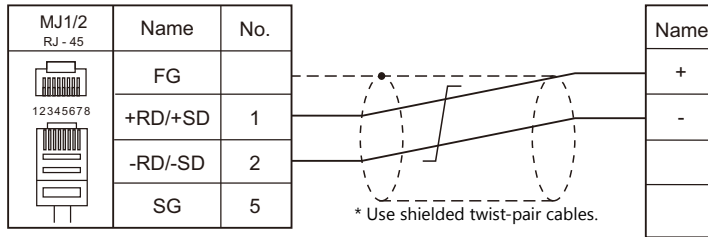

Wiring diagram 2 - M4

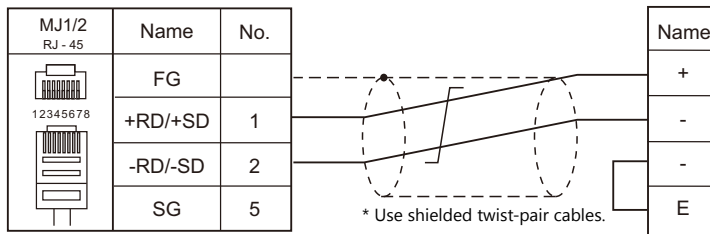

15.2 Temperature Controller/Servo/Inverter Connection

Serial Connection

Laser Marker

PLC Selection on the Editor	Model	Port	Signal Level	Connection		Lst File
				CN1	MJ1/MJ2	
LP-400	LP-410U, LP-410TU, LP-411U, LP-411TU, LP-420S9U, LP-420S9TU, LP-421S9U, LP-421S9TU, LP-425S9U, LP-425S9TU, LP-430U, LP-430TU, LP-431U, LP-431TU, LP-435U, LP-435TU	COM2	RS-232C	Wiring diagram 1 - C2	Wiring diagram 1 - M2	LP-400.Lst

Eco-POWER METER

PLC Selection on the Editor	Model		Port	Signal Level	Connection		Lst File
					CN1	MJ1/MJ2	
KW Series	KW1M	AKW1110 AKW1111	Terminal	RS-485	Wiring diagram 1 - C4	Wiring diagram 1 - M4	Pana_KW1M. Lst
	KW1M-H	AKW1121	Terminal	RS-485	Wiring diagram 1 - C4	Wiring diagram 1 - M4	
	KW1M-R	AKW1000 AKW1000K	Terminal	RS-232C	Wiring diagram 2 - C2	Wiring diagram 2 - M2	
		AKW1131 AKW1131K	Terminal	RS-485	Wiring diagram 1 - C4	Wiring diagram 1 - M4	
	KW2G	AKW2010G	Terminal	RS-485	Wiring diagram 1 - C4	Wiring diagram 1 - M4	Pana_KW2G. Lst
	KW2G-H	AKW2020G	Terminal	RS-485	Wiring diagram 1 - C4	Wiring diagram 1 - M4	
	KW4M	AKW5111 AKW5211	Terminal	RS-485	Wiring diagram 1 - C4	Wiring diagram 1 - M4	Pana_KW4M. Lst
	KW7M	AKW7111	Terminal	RS-485	Wiring diagram 1 - C4	Wiring diagram 1 - M4	Pana_KW7M. Lst
KW8M	AKW8111 AKW8111H AKW8115	Terminal	RS-485	Wiring diagram 1 - C4	Wiring diagram 1 - M4	Pana_KW8M. Lst	

Servo Amplifier

PLC Selection on the Editor	Model	Port	Signal Level	Connection		Lst File
				CN1	MJ1/MJ2	
MINAS A4 series	MADDTxxxx MBDDTxxxx MCDDTxxxx MDDDTxxxx MEDDTxxxx MFDDTxxxx MGDDTxxxx	CN X4	RS-232C	Wiring diagram 3 - C2	Wiring diagram 3 - M2	PanaA4. Lst
			RS-485	Wiring diagram 2 - C4	Wiring diagram 2 - M4	

15.2.1 LP-400 Series

Communication Setting

Editor

Communication setting

(Underlined setting: default)

Item	Setting	Remarks
Connection Mode	<u>1:1</u> / Multi-link2 / Multi-link2 (Ethernet)	
Signal Level	RS-232C	
Baud Rate	4800 / <u>9600</u> / 19200 / 38400 bps	
Data Length	8 bits	
Stop Bit	<u>1</u> / 2 bits	
Parity	<u>None</u> / Odd / Even	
Sum Check	Provided / <u>Not provided</u>	
CR/LF	<u>CR</u> / CR/LF	

Laser Marker

Parameter

Set communication parameters using the console. For more information, refer to the instruction manual for the laser marker issued by the manufacturer.

(Underlined setting: default)

Mode	Sub Menu	Item	Setting	Remarks
Environment setting	Communication I/O	Baud Rate	4800 / <u>9600</u> / 19200 / 38400 bps	
		Data Length	8 bit	
		Parity	<u>None</u> / Odd / Even	
		Stop Bits	<u>1</u> / 2 bit	
		Delimit	<u>CR</u> / CR+LF	
		Check Sum	<u>None</u> / Provided	

DIP switch

DPS-8	SW No.	Contents	Setting	Remarks												
	1	System reserve	OFF: System reserved													
	2	External control method	ON: RS-232C control													
	3	Buzzer at an occurrence of error	ON: Not sound OFF: Sound													
	4	Password lock	ON: Password lock invalid OFF: Password lock valid													
	5	Method to switch to remote mode	<table border="1"> <thead> <tr> <th>SW5</th> <th>SW6</th> <th>Operation</th> </tr> </thead> <tbody> <tr> <td>OFF</td> <td>OFF</td> <td>Pressing the remote button on the front of the controller</td> </tr> <tr> <td>ON</td> <td>OFF</td> <td>Inputting "REMOTE IN" on the terminal block</td> </tr> <tr> <td>OFF</td> <td>ON</td> <td>Turning the key switch ON</td> </tr> </tbody> </table>	SW5	SW6	Operation	OFF	OFF	Pressing the remote button on the front of the controller	ON	OFF	Inputting "REMOTE IN" on the terminal block	OFF	ON	Turning the key switch ON	
	SW5		SW6	Operation												
	OFF		OFF	Pressing the remote button on the front of the controller												
	ON	OFF	Inputting "REMOTE IN" on the terminal block													
OFF	ON	Turning the key switch ON														
6																
7	System reserve	OFF: System reserved														
8	System reserve	OFF: System reserved														

* Keep the power off when changing the DIP switch setting.

* For communications with the V series, be sure to switch to the remote mode.

Wiring on the terminal block

If printing cannot be performed correctly, check the wiring status on the terminal block.

- Short-circuit A11 "LASER STOP-" and A12 "LASER STOP+". When they are opened, the auto shutter is closed and printing is disabled.
- For B11 "EMER. -" and B12 "EMER. +", connect the normally-closed type emergency stop switch or short-circuit them. When they are opened, the laser power is turned off and printing is disabled.
- Connect the power supply (internal or external) to A2 "IN COM." and B2 "OUT COM.". Otherwise, the laser marker will not be activated.
When using an internal power supply, short-circuit A1 "+12V OUT" and A2 "IN COM." as well as B1 "0V OUT" and B2 "OUT COM.". When using an external power supply, remove short bars from between A1 "+12V OUT" and A2 "IN COM." as well as B1 "0V OUT" and B2 "OUT COM.".

Available Device Memory

The available setting range of device memory varies depending on the model. Be sure to set within the range available for the model to be used. Use [TYPE] when assigning indirect device memory for macro programs.

Device Memory	TYPE	Remarks
FNM (file name)	00H	
FNO (file number change)	01H	
STR (text to print)	02H	
MCS (text to print (1-byte character))	03H	
LMT (limit date and time)	04H	
CNT (counter)	05H	Double-word
LTC (lot condition)	06H	
CDF (logo file)	07H	
ALC (global condition)	08H	Double-word
CDC (logo condition)	09H	Double-word
FST (file setting)	0AH	Double-word
WDC (print line width correction)	0BH	
WTC (print quality adjustment)	0CH	
TRG (trigger condition)	0DH	
DLY (delay)	0EH	
YMD (year, month, day, time)	0FH	
ERA (year of Japanese era)	10H	
ENV (input/output environment)	11H	
PST (print setting)	12H	
STS (status request)	13H	Read only
RKC (rank condition)	14H	
RKS (rank text)	15H	
OFC (offset condition)	16H	
OFS (offset)	17H	Double-word

FNM (file name)

Address	Name	Setting Range
0000	File name	File name (CHAR 20 bytes)

FNO (file number)

Address	Name	Setting Range
0000	File number	0 to 1023, 9999 * * 9999: New

STR (text to print)

Address	Name	Setting Range
0000 to 0029	Text to print in line number 01	Text to print (CHAR 60 bytes)
0030 to 0059	Text to print in line number 02	
:	:	
1770 to 1799	Text to print in line number 60	

MCS (text to print (1-byte character))

Address	Name	Setting Range
0000 to 0014	Text to print in line number 01 (1-byte character)	Text to print (CHAR 30 bytes)
0015 to 0029	Text to print in line number 02 (1-byte character)	
:	:	
0885 to 0899	Text to print in line number 60 (1-byte character)	

LMT (limit date and time)

Address	Name	Setting Range
0101	Limit number 1	Limit
0102		Unit
0103		Start day
0201	Limit number 2	Limit
0202		Unit
0203		Start day
:	:	:
0801	Limit number 8	Limit
0802		Unit
0803		Start day

CNT (counter)

Address	Name	Setting Range
0000	Counter 0	Current value
0001		Initial value
0002		End value
0003		Step
0004		Count source
0005		Flag
0100	Counter 1	Current value
0101		Initial value
0102		End value
0103		Step
0104		Count source
0105		Flag
:	:	:
0700	Counter 7	Current value
0701		Initial value
0702		End value
0703		Step
0704		Count source
0705		Flag

LTC (lot condition)

Address	Name		Setting Range
0000	Lot function number 0	Lot condition	00: Current 01 to 08: Limit 1 to 8 10 to 17: Counter 0 to 7
0001		Limit condition	0: Year or counter 1: Month 2: Day 3: Year and month 4: Month and day 5: Day of the week 6: Hour 7: Week 8: Minute
0100	Lot function number 1	Lot condition	00: Current 01 to 08: Limit 1 to 8 10 to 17: Counter 0 to 7
0101		Limit condition	0: Year or counter 1: Month 2: Day 3: Year and month 4: Month and day 5: Day of the week 6: Hour 7: Week 8: Minute
:	:	:	:
0700	Lot function number 7	Lot condition	00: Current 01 to 08: Limit 1 to 8 10 to 17: Counter 0 to 7
0701		Limit condition	0: Year or counter 1: Month 2: Day 3: Year and month 4: Month and day 5: Day of the week 6: Hour 7: Week 8: Minute

CDF (logo file)

Address	Name	Setting Range
0000 to 0127	Name of logo file number 00	Logo file name (CHAR 256 bytes)
0128 to 0255	Name of logo file number 01	
:	:	
1920 to 2047	Name of logo file number 15	

ALC (global condition)

Address	Name	Setting Range
0000	X offset	LP-430U/430TU/420S9U/420S9TU/410U/410TU -55000 to +55000: -055.000 to +055.000 mm LP-431U/431TU/421S9U/421S9TU/411U/411TU -27500 to +27500: -027.500 to +027.500 mm
0001	Y offset	LP-435U/435TU/425S9U/425S9TU -80000 to +80000: -080.000 to +080.000 mm
0002	Rotation offset	-18000 to +18000: -180.00° to +180.00°
0003	Number of overprint times	1 to 99
0004	Time to stop overprint	0 to 10: 0 to 1.0 sec.
0005	Flip horizontal	0: Not flip 1: Flip
0006	Flip vertical	0: Not flip 1: Flip

CDC (logo condition)

Address	Name	Setting Range
0000	Area number	0 to F (HEX)
0001	X magnification	10000 to 1000000: 10.000 to 1000.000%
0002	Y magnification	10000 to 1000000: 10.000 to 1000.000%
0003	X position	-300000 to +300000: -300.000 to +300.000 mm
0004	Y position	-300000 to +300000: -300.000 to +300.000 mm
0005	Rotation angle	-18000 to +18000: -180.00° to +180.00°
0006	Laser power offset	0 to 200%
0007	Scan speed correction	5 to 500%
0100	Area number	0 to F (HEX)
0101	X magnification	10000 to 1000000: 10.000 to 1000.000%
0102	Y magnification	10000 to 1000000: 10.000 to 1000.000%
0103	X position	-300000 to +300000: -300.000 to +300.000 mm
0104	Y position	-300000 to +300000: -300.000 to +300.000 mm
0105	Rotation angle	-18000 to +18000: -180.00° to +180.00°
0106	Laser power offset	0 to 200%
0107	Scan speed correction	5 to 500%
:	:	:
1500	Area number	0 to F (HEX)
1501	X magnification	10000 to 1000000: 10.000 to 1000.000%
1502	Y magnification	10000 to 1000000: 10.000 to 1000.000%
1503	X position	-300000 to +300000: -300.000 to +300.000 mm
1504	Y position	-300000 to +300000: -300.000 to +300.000 mm
1505	Rotation angle	-18000 to +18000: -180.00° to +180.00°
1506	Laser power offset	0 to 200%
1507	Scan speed correction	5 to 500%

FST (file setting)

Address	Name	Setting Range
0000	Laser power (LPW)	0005 to 1000: 000.5 to 100.0 (0.5 increments)
0001	Scan speed (SSP)	LP-430U/430TU/435U/435TU/420S9U/420S9TU/425S9U/425S9TU/410U/410TU 00001 to 12000 mm/s LP-431U/431TU/421S9U/421S9TU/411U/411TU 00001 to 06000 mm/s
0002	Frequency (MPL)	0: 5 kHz 1: 10 kHz 2: 20 kHz
0003	Print interval (INT)	00000 to 30000: 0000.0 to 3000.0 mm
0004	Line speed (LSP)	LP-430U/430TU/420S9U/420S9TU/425S9U/425S9TU/435U/435TU 60 to 240000: 000.060 to 240.000 m/min LP-431U/431TU/421S9U/421S9TU 60 to 120000: 000.060 to 120.000 m/min LP-410U/410TU 60 to 170000: 000.060 to 170.000 m/min LP-411U/411TU 60 to 85000: 000.060 to 085.000 m/min
0005	Encoder pulse (ENC)	00500 to 60000: 005.00 to 600.00 pulse/mm

WDC (print line width correction)

Address	Name	Setting Range
0000	Print line width correction	0010 to 2000: 0.010 to 2.000 mm
0001	Filling interval	0010 to 2000: 0.010 to 2.000 mm

WTC (print quality adjustment)

Address	Name	Setting Range
0000	Laser start point adjustment	-100 to +100
0001	Laser end point adjustment	-100 to +100
0002	Edge adjustment	000 to 100
0003	Curve adjustment	000 to 100
0004	Weight adjustment	000 to 100
0005	Spare scanning time	0000 to 1000: 00.00 to 10.00 msec.

TRG (trigger condition)

Address	Name	Setting Range
0000	Direction of movement	0: Standstill 1: Left 2: Right 3: Forward 4: Backward
0001	Encoder	0: None 1: Provided
0002	Trigger type	0: Trigger 1: Printing at equal intervals

DLY (delay)

Address	Name	Setting Range
0000	When "standstill" is specified for movement direction in trigger condition (TRG0000 = 0): Delay distance When any direction other than "standstill" is specified for movement direction in trigger condition (TRG0000 ≠ 0): Delay time	Delay distance 00000 to 50000: 000.00 to 500.00 mm Delay time 000000 to 005000 msec.

YMD (year, month, day, time)

Address	Name	Setting Range
0000	Year of the Christian era	1980 to 2099
0001	Month	1 to 12
0002	Day	1 to 31
0003	Hour	0 to 23
0004	Minute	0 to 59
0005	Second	0 to 59

ERA (year of Japanese era)

Address	Name	Setting Range
0000	Year of Japanese era	01 to 99

ENV (input/output environment)

Address	Name	Setting Range
0000	One-shot time	002 to 510 msec.
0001	Double trigger detection	0: Without output 1: With output

PST (print setting)

Address	Name	Setting Range
0001	Print mode (MKM)	0: Printing suspend 1: Printing restart
0002	Laser control (LSR)	0: OFF 1: ON

STS (status request)

Address	Name	Setting Range
0000	Error status	0: No error 1: Error occurring
0001	Laser excitation status	0: Excitation OFF 1: During excitation 2: Excitation finish
0002	Standby status	0: Standby 1: During printing
0003	Print ready status	0: Busy 1: Ready
0004	Trigger status	0: Trigger OFF 1: Trigger ON

RKC (rank condition)

Address	Name	Setting Range
0000	Parallel input condition	1: 4 bits × 4 2: 8 bits × 2

RKS (rank text)

Address	Name	Setting Range
0000 to 0008	Set text in rank number 1	Set text (CHAR 18 bytes)
0009 to 0017	Set text in rank number 2	
:	:	
4599 to 4607	Set text in rank number 511	

OFC (offset condition)

Address	Name	Setting Range
00000	Parallel input condition	0: No offset 1: Lower 4 bits 2: Lower 8 bits

OFS (offset)

Address		Name	Setting Range
00000	Offset number 0	Offset X	LP-430U/430TU/420S9U/420S9TU/410U/410TU -55000 to +55000: -055.000 to +055.000 mm LP-431U/431TU/421S9U/421S9TU/411U/411TU -27500 to +27500: -027.500 to +027.500 mm LP-435U/435TU/425S9U/425S9TU -80000 to +80000: -080.000 to +080.000 mm
00001		Offset Y	
00002		Offset θ	-18000 to +18000: -180.00° to +180.00°
00100	Offset number 1	Offset X	LP-430U/430TU/420S9U/420S9TU/410U/410TU -55000 to +55000: -055.000 to +055.000 mm LP-431U/431TU/421S9U/421S9TU/411U/411TU -27500 to +27500: -027.500 to +027.500 mm LP-435U/435TU/425S9U/425S9TU -80000 to +80000: -080.000 to +080.000 mm
00101		Offset Y	
00102		Offset θ	-18000 to +18000: -180.00° to +180.00°
:		:	:
25500	Offset number 255	Offset X	LP-430U/430TU/420S9U/420S9TU/410U/410TU -55000 to +55000: -055.000 to +055.000 mm LP-431U/431TU/421S9U/421S9TU/411U/411TU -27500 to +27500: -027.500 to +027.500 mm LP-435U/435TU/425S9U/425S9TU -80000 to +80000: -080.000 to +080.000 mm
25501		Offset Y	
25502		Offset θ	-18000 to +18000: -180.00° to +180.00°

Indirect Device Memory Designation

	15	8 7	0
n+0	Models (11 to 18)		Device type
n+1	Address No.		
n+2	Expansion code *		Bit designation
n+3	00		Station number

* In the expansion code, set which word, higher or lower, is to be read when a double-word address is specified.

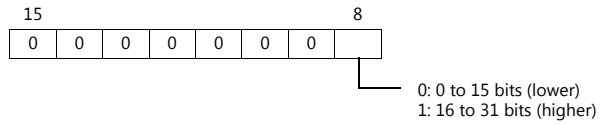

PLC_CTL

Macro command "PLC_CTL F0 F1 F2"

Contents		F0	F1 (= \$u n)		F2	
File overwrite		1 - 8 (PLC1 - 8)	n	Station number: 0 (fixed)	2	
			n + 1	Command: A1H		
File registration		1 - 8 (PLC1 - 8)	n	Station number: 0 (fixed)	3	
			n + 1	Command: A2H		
			n + 2	File number LP-430U/430TU/431U/431TU 0 to 1023 LP-435U/435TU/425S9U/425S9TU/ 420S9U/420S9TU/410U/410TU/ 421S9U/421S9TU/411U/411TU 0 to 2047		
Reading of lot text		1 - 8 (PLC1 - 8)	n	Station number: 0 (fixed)	4	
			n + 1	Command: 23H		
			n + 2	Lot number: 0 to 7		
			n + 3	Period number		
			n + 4 to n + 5	Start of period *1		
			n + 6 to n + 7	End of period *1		
			n + 8 to n + 16	Set text		
Lot text setting		1 - 8 (PLC1 - 8)	n	Station number: 0 (fixed)	8 + number of words of set text (max. 9 words)	
			n + 1	Command: A3H		
			n + 2	Lot number: 0 to 7		
			n + 3	Period number		
			n + 4 to n + 5	Start of period *2		
			n + 6 to n + 7	End of period *2		
			n + 8 to n + 16	Set text		
Reading of step & repeat setting	Setting delete	1 - 8 (PLC1 - 8)	n	Station number: 0 (fixed)	3	
			n + 1	Command: 24H		
			n + 2	List line: 00 to 99		
			n + 3	Fine-adjustment type: 0 (setting delete)		
	Single fine-adjustment		1 - 8 (PLC1 - 8)	n	Station number: 0 (fixed)	3
				n + 1	Command: 24H	
				n + 2	List line: 00 to 99	
				n + 3	Fine-adjustment type: 1 (single adjustment)	
				n + 4	Target line: 001 to 100	
				n + 5	Target column: 001 to 100	
				n + 6 to n + 7	X-axis adjustment LP-430U/430TU/420S9U/420S9TU/ 410U/410TU -55000 to +55000: -055.000 to +055.000 mm LP-431U/431TU/421S9U/421S9TU/ 411U/411TU	
	n + 8 to n + 9	Y-axis adjustment -27500 to +27500: -027.500 to +027.500 mm LP-435U/435TU/425S9U/425S9TU -80000 to +80000: -080.000 to +080.000 mm				
	Print OFF		1 - 8 (PLC1 - 8)	n	Station number: 0 (fixed)	3
				n + 1	Command: 24H	
				n + 2	List line: 00 to 99	
n + 3				Fine-adjustment type: 2 (print OFF)		
n + 4				Target line: 001 to 100		
n + 5	Target column: 001 to 100					

*1 When "-1" is set for both start of period and end of period, the reading period is set as undefined.

*2 When writing is executed while "-1" is set for both start of period and end of period, the setting is deleted.

Contents		F0	F1 (= \$u n)		F2	
Reading of step & repeat setting	All columns fine-adjustment	1 - 8 (PLC1 - 8)	n	Station number: 0 (fixed)		3
			n + 1	Command: 24H		
			n + 2	List line: 00 to 99		
			n + 3	Fine-adjustment type: 3 (all columns adjustment)		
			n + 4	Target column: 001 to 100		
			n + 5 to n + 6	X-axis adjustment	LP-430U/430TU/420S9U/420S9TU/410U/410TU -55000 to +55000: -055.000 to +055.000 mm LP-431U/431TU/421S9U/421S9TU/411U/411TU	
	n + 7 to n + 8	Y-axis adjustment	-27500 to +27500: -027.500 to +027.500 mm LP-435U/435TU/425S9U/425S9TU -80000 to +80000: -080.000 to +080.000 mm			
	All lines fine-adjustment	1 - 8 (PLC1 - 8)	n	Station number: 0 (fixed)		3
			n + 1	Command: 24H		
			n + 2	List line: 00 to 99		
			n + 3	Fine-adjustment type: 4 (all lines adjustment)		
			n + 4	Target line: 001 to 100		
			n + 5 to n + 6	X-axis adjustment	LP-430U/430TU/420S9U/420S9TU/410U/410TU -55000 to +55000: -055.000 to +055.000 mm LP-431U/431TU/421S9U/421S9TU/411U/411TU	
	n + 7 to n + 8	Y-axis adjustment	-27500 to +27500: -027.500 to +027.500 mm LP-435U/435TU/425S9U/425S9TU -80000 to +80000: -080.000 to +080.000 mm			
	Column fine-adjustment	1 - 8 (PLC1 - 8)	n	Station number: 0 (fixed)		3
			n + 1	Command: 24H		
			n + 2	List line: 00 to 99		
			n + 3	Fine-adjustment type: 5 (column adjustment)		
			n + 4	Target column: 001 to 100		
			n + 5 to n + 6	X-axis adjustment	LP-430U/430TU/420S9U/420S9TU/410U/410TU -55000 to +55000: -055.000 to +055.000 mm LP-431U/431TU/421S9U/421S9TU/411U/411TU	
n + 7 to n + 8	Y-axis adjustment	-27500 to +27500: -027.500 to +027.500 mm LP-435U/435TU/425S9U/425S9TU -80000 to +80000: -080.000 to +080.000 mm				
Line fine-adjustment	1 - 8 (PLC1 - 8)	n	Station number: 0 (fixed)		3	
		n + 1	Command: 24H			
		n + 2	List line: 00 to 99			
		n + 3	Fine-adjustment type: 6 (line adjustment)			
		n + 4	Target line: 001 to 100			
		n + 5 to n + 6	X-axis adjustment	LP-430U/430TU/420S9U/420S9TU/410U/410TU -55000 to +55000: -055.000 to +055.000 mm LP-431U/431TU/421S9U/421S9TU/411U/411TU		
n + 7 to n + 8	Y-axis adjustment	-27500 to +27500: -027.500 to +027.500 mm LP-435U/435TU/425S9U/425S9TU -80000 to +80000: -080.000 to +080.000 mm				

Contents		F0	F1 (= \$u n)		F2
Writing of step & repeat setting	Setting delete	1 - 8 (PLC1 - 8)	n	Station number: 0 (fixed)	4
			n + 1	Command: A4H	
			n + 2	List line: 00 to 99	
			n + 3	Fine-adjustment type: 0 (setting delete)	
	Single fine-adjustment	1 - 8 (PLC1 - 8)	n	Station number: 0 (fixed)	10
			n + 1	Command: A4H	
			n + 2	List line: 00 to 99	
			n + 3	Fine-adjustment type: 1 (single adjustment)	
			n + 4	Target line: 001 to 100	
			n + 5	Target column: 001 to 100	
	Print OFF	1 - 8 (PLC1 - 8)	n	Station number: 0 (fixed)	6
			n + 1	Command: A4H	
			n + 2	List line: 00 to 99	
			n + 3	Fine-adjustment type: 2 (print OFF)	
			n + 4	Target line: 001 to 100	
			n + 5	Target column: 001 to 100	
	All columns fine-adjustment	1 - 8 (PLC1 - 8)	n	Station number: 0 (fixed)	9
			n + 1	Command: A4H	
			n + 2	List line: 00 to 99	
			n + 3	Fine-adjustment type: 3 (all columns adjustment)	
			n + 4	Target column: 001 to 100	
			n + 5 to n + 6	X-axis adjustment LP-430U/430TU/420S9U/420S9TU/410U/410TU -55000 to +55000: -055.000 to +055.000 mm LP-431U/431TU/421S9U/421S9TU/411U/411TU -27500 to +27500: -027.500 to +027.500 mm	
	n + 7 to n + 8	Y-axis adjustment LP-435U/435TU/425S9U/425S9TU -80000 to +80000: -080.000 to +080.000 mm			
	All lines fine-adjustment	1 - 8 (PLC1 - 8)	n	Station number: 0 (fixed)	9
n + 1			Command: A4H		
n + 2			List line: 00 to 99		
n + 3			Fine-adjustment type: 4 (all lines adjustment)		
n + 4			Target line: 001 to 100		
n + 5 to n + 6			X-axis adjustment LP-430U/430TU/420S9U/420S9TU/410U/410TU -55000 to +55000: -055.000 to +055.000 mm LP-431U/431TU/421S9U/421S9TU/411U/411TU -27500 to +27500: -027.500 to +027.500 mm		
n + 7 to n + 8	Y-axis adjustment LP-435U/435TU/425S9U/425S9TU -80000 to +80000: -080.000 to +080.000 mm				

Contents		F0	F1 (= \$u n)		F2	
Writing of step & repeat setting	Column fine-adjustment	1 - 8 (PLC1 - 8)	n	Station number: 0 (fixed)		9
			n + 1	Command: A4H		
			n + 2	List line: 00 to 99		
			n + 3	Fine-adjustment type: 5 (column adjustment)		
			n + 4	Target column: 001 to 100		
			n + 5 to n + 6	X-axis adjustment	LP-430U/430TU/420S9U/420S9TU/ 410U/410TU -55000 to +55000: -055.000 to +055.000 mm LP-431U/431TU/421S9U/421S9TU/ 411U/411TU -27500 to +27500: -027.500 to +027.500 mm	
			n + 7 to n + 8	Y-axis adjustment	LP-435U/435TU/425S9U/425S9TU -80000 to +80000: -080.000 to +080.000 mm	
	Line fine-adjustment	1 - 8 (PLC1 - 8)	n	Station number: 0 (fixed)		9
			n + 1	Command: A4H		
			n + 2	List line: 00 to 99		
			n + 3	Fine-adjustment type: 6 (line adjustment)		
			n + 4	Target line: 001 to 100		
			n + 5 to n + 6	X-axis adjustment	LP-430U/430TU/420S9U/420S9TU/ 410U/410TU -55000 to +55000: -055.000 to +055.000 mm LP-431U/431TU/421S9U/421S9TU/ 411U/411TU -27500 to +27500: -027.500 to +027.500 mm	
			n + 7 to n + 8	Y-axis adjustment	LP-435U/435TU/425S9U/425S9TU -80000 to +80000: -080.000 to +080.000 mm	

Contents		F0	F1 (= \$u n)		F2	
Reading of text condition	Straight/ Proportional/ Monospace	1 - 8 (PLC1 - 8)	n	Station number: 0 (fixed)	3	
			n + 1	Command: 25H		
			n + 2	Condition number: 01 to 60		
			n + 3	Area number: 0 to F (HEX)		
			n + 4	Start line: 01 to 60		
			n + 5	End line: 01 to 60		
			n + 6	Standard character arrangement 0: Straight 1: Proportional 2: Monospace		
			n + 7	Text origin 0: Left end 1: Center 2: Right end		
			n + 8 to n + 9	Character height		LP-430U/430TU/420S9U/420S9TU/ 410U/410TU 200 to 110000: 000.200 to 110.000 mm LP-431U/431TU/421S9U/421S9TU/ 411U/411TU 200 to 55000: 000.200 to 055.000 mm LP-435U/435TU/425S9U/425S9TU 200 to 160000: 000.200 to 160.000 mm
			n + 10 to n + 11	Character width		LP-430U/430TU/420S9U/420S9TU/ 410U/410TU -55000 to +55000: -055.000 to +055.000 mm LP-431U/431TU/421S9U/421S9TU/ 411U/411TU -27500 to +27500: -027.500 to +027.500 mm LP-435U/435TU/425S9U/425S9TU -80000 to +80000: -080.000 to +080.000 mm
			n + 12 to n + 13	X position		LP-430U/430TU/420S9U/420S9TU/ 410U/410TU 0 to 110000: 000.000 to 110.000 mm LP-431U/431TU/421S9U/421S9TU/ 411U/411TU 0 to 55000: 000.000 to 055.000 mm LP-435U/435TU/425S9U/425S9TU 000 to 160000: 000.000 to 160.000 mm
			n + 14 to n + 15	Y position		LP-430U/430TU/420S9U/420S9TU/ 410U/410TU 0 to 110000: 000.000 to 110.000 mm LP-431U/431TU/421S9U/421S9TU/ 411U/411TU 0 to 55000: 000.000 to 055.000 mm LP-435U/435TU/425S9U/425S9TU 000 to 160000: 000.000 to 160.000 mm
			n + 16 to n + 17	Spaces between characters/ Entire width		LP-430U/430TU/420S9U/420S9TU/ 410U/410TU 0 to 110000: 000.000 to 110.000 mm LP-431U/431TU/421S9U/421S9TU/ 411U/411TU 0 to 55000: 000.000 to 055.000 mm LP-435U/435TU/425S9U/425S9TU 000 to 160000: 000.000 to 160.000 mm
			n + 18 to n + 19	Spaces between lines		LP-430U/430TU/420S9U/420S9TU/ 410U/410TU 0 to 110000: 000.000 to 110.000 mm LP-431U/431TU/421S9U/421S9TU/ 411U/411TU 0 to 55000: 000.000 to 055.000 mm LP-435U/435TU/425S9U/425S9TU 000 to 160000: 000.000 to 160.000 mm
			n + 20	Tilting angle -18000 to +18000: -180.00° to +180.00°		
			n + 21	Font designation 1: Character font 1 2: Character font 2		
			n + 22	Line width of bold character		LP-430U/430TU/435U/435TU/420S9U/ 420S9TU/425S9U/425S9TU/410U/ 410TU 0 to 6000: 0.000 to 6.000 mm LP-431U/431TU/421S9U/421S9TU/ 411U/411TU 0 to 4000: 0.000 to 4.000 mm
n + 23	Laser power offset: 000 to 200%					
n + 24	Scan speed correction: 005 to 500%					

Contents		F0	F1 (= \$u n)		F2		
Reading of text condition	Arc-shaped printing	1 - 8 (PLC1 - 8)	n	Station number: 0 (fixed)		3	
			n + 1	Command: 25H			
			n + 2	Condition number: 01 to 60			
			n + 3	Area number: 0 to F (HEX)			
			n + 4	Start line: 01 to 60			
			n + 5	End line: 01 to 60			
			n + 6	Standard character arrangement 3: Printing out of the arc (clockwise) 4: Printing inside the arc (counterclockwise)			
			n + 7	Text origin 0: Left end 1: Center 2: Right end			
			n + 8 to n + 9	Character height	LP-430U/430TU/420S9U/420S9TU/ 410U/410TU 200 to 110000: 000.200 to 110.000 mm LP-431U/431TU/421S9U/421S9TU/ 411U/411TU 200 to 55000: 000.200 to 055.000 mm LP-435U/435TU/425S9U/425S9TU 200 to 160000: 000.200 to 160.000 mm		
			n + 10 to n + 11	Character width	LP-430U/430TU/420S9U/420S9TU/ 410U/410TU 0 to 110000: 000.000 to 110.000 mm LP-431U/431TU/421S9U/421S9TU/ 411U/411TU 0 to 55000: 000.000 to 055.000 mm LP-435U/435TU/425S9U/425S9TU 000 to 160000: 000.000 to 160.000 mm		
			n + 12 to n + 13	Center position X -300000 to +300000: -300.000 to +300.000 mm			
			n + 14 to n + 15	Center position Y -300000 to +300000: -300.000 to +300.000 mm			
			n + 16 to n + 17	Radius 0 to +300000: 000.000 to +300.000 mm			
			n + 18 to n + 19	Radius of spaces between lines	LP-430U/430TU/420S9U/420S9TU/ 410U/410TU 0 to 110000: 000.000 to 110.000 mm LP-431U/431TU/421S9U/421S9TU/ 411U/411TU 0 to 55000: 000.000 to 055.000 mm LP-435U/435TU/425S9U/425S9TU 000 to 160000: 000.000 to 160.000 mm		
			n + 20	Start angle -18000 to +18000: -180.00 to +180.00°			
			n + 21	Angle of spaces between characters -18000 to +18000: -180.00 to +180.00°			
			n + 22	Font designation 1: Character font 1 2: Character font 2			
			n + 23	Line width of bold character	LP-430U/430TU/435U/435TU/420S9U/ 420S9TU/425S9U/425S9TU/410U/ 410TU 0 to 6000: 0.000 to 6.000 mm LP-431U/431TU/421S9U/421S9TU/ 411U/411TU 0 to 4000: 0.000 to 4.000 mm		
			n + 24	Laser power offset: 000 to 200%			
			n + 25	Scan speed correction: 005 to 500%			

Contents		F0	F1 (= \$u n)		F2
Writing of text condition	Straight/ Proportional/ Monospace	1 - 8 (PLC1 - 8)	n	Station number: 0 (fixed)	25
			n + 1	Command: A5H	
			n + 2	Condition number: 01 to 60	
			n + 3	Area number: 0 to F (HEX)	
			n + 4	Start line: 01 to 60	
			n + 5	End line: 01 to 60	
			n + 6	Standard character arrangement 0: Straight 1: Proportional 2: Monospace	
			n + 7	Text origin 0: Left end 1: Center 2: Right end	
			n + 8 to n + 9	Character height LP-430U/430TU/420S9U/420S9TU/ 410U/410TU 200 to 110000: 000.200 to 110.000 mm LP-431U/431TU/421S9U/421S9TU/ 411U/411TU 200 to 55000: 000.200 to 055.000 mm LP-435U/435TU/425S9U/425S9TU 200 to 160000: 000.200 to 160.000 mm	
			n + 10 to n + 11	Character width LP-430U/430TU/420S9U/420S9TU/ 410U/410TU -55000 to +55000: -055.000 to +055.000 mm LP-431U/431TU/421S9U/421S9TU/ 411U/411TU -27500 to +27500: -027.500 to +027.500 mm LP-435U/435TU/425S9U/425S9TU -80000 to +80000: -080.000 to +080.000 mm	
			n + 12 to n + 13	X position	
			n + 14 to n + 15	Y position	
			n + 16 to n + 17	Spaces between characters/ Entire width LP-430U/430TU/420S9U/420S9TU/ 410U/410TU 0 to 110000: 000.000 to 110.000 mm LP-431U/431TU/421S9U/421S9TU/ 411U/411TU 0 to 55000: 000.000 to 055.000 mm LP-435U/435TU/425S9U/425S9TU 000 to 160000: 000.000 to 160.000 mm	
			n + 18 to n + 19	Spaces between lines LP-430U/430TU/420S9U/420S9TU/ 410U/410TU 0 to 110000: 000.000 to 110.000 mm LP-431U/431TU/421S9U/421S9TU/ 411U/411TU 0 to 55000: 000.000 to 055.000 mm LP-435U/435TU/425S9U/425S9TU 000 to 160000: 000.000 to 160.000 mm	
			n + 20	Tilting angle -18000 to +18000: -180.00° to +180.00°	
			n + 21	Font designation 1: Character font 1 2: Character font 2	
n + 22	Line width of bold character LP-430U/430TU/435U/435TU/420S9U/ 420S9TU/425S9U/425S9TU/410U/ 410TU 0 to 6000: 0.000 to 6.000 mm LP-431U/431TU/421S9U/421S9TU/ 411U/411TU 0 to 4000: 0.000 to 4.000 mm				
n + 23	Laser power offset: 000 to 200%				
n + 24	Scan speed correction: 005 to 500%				

Contents		F0	F1 (= \$u n)		F2		
Writing of text condition	Arc-shaped printing	1 - 8 (PLC1 - 8)	n	Station number: 0 (fixed)		26	
			n + 1	Command: A5H			
			n + 2	Condition number: 01 to 60			
			n + 3	Area number: 0 to F (HEX)			
			n + 4	Start line: 01 to 60			
			n + 5	End line: 01 to 60			
			n + 6	Standard character arrangement 3: Printing out of the arc (clockwise) 4: Printing inside the arc (counterclockwise)			
			n + 7	Text origin 0: Left end 1: Center 2: Right end			
			n + 8 to n + 9	Character height	LP-430U/430TU/420S9U/420S9TU/ 410U/410TU 200 to 110000: 000.200 to 110.000 mm LP-431U/431TU/421S9U/421S9TU/ 411U/411TU 200 to 55000: 000.200 to 055.000 mm LP-435U/435TU/425S9U/425S9TU 200 to 160000: 000.200 to 160.000 mm		
			n + 10 to n + 11	Character width	LP-430U/430TU/420S9U/420S9TU/ 410U/410TU 0 to 110000: 000.000 to 110.000 mm LP-431U/431TU/421S9U/421S9TU/ 411U/411TU 0 to 55000: 000.000 to 055.000 mm LP-435U/435TU/425S9U/425S9TU 000 to 160000: 000.000 to 160.000 mm		
			n + 12 to n + 13	Center position X -300000 to +300000: -300.000 to +300.000 mm			
			n + 14 to n + 15	Center position Y -300000 to +300000: -300.000 to +300.000 mm			
			n + 16 to n + 17	Radius 0 to +300000: 000.000 to +300.000 mm			
			n + 18 to n + 19	Radius of spaces between lines	LP-430U/430TU/420S9U/420S9TU/ 410U/410TU 0 to 110000: 000.000 to 110.000 mm LP-431U/431TU/421S9U/421S9TU/ 411U/411TU 0 to 55000: 000.000 to 055.000 mm LP-435U/435TU/425S9U/425S9TU 000 to 160000: 000.000 to 160.000 mm		
			n + 20	Start angle -18000 to +18000: -180.00 to +180.00°			
			n + 21	Angle of spaces between characters -18000 to +18000: -180.00 to +180.00°			
			n + 22	Font designation 1: Character font 1 2: Character font 2			
			n + 23	Line width of bold character	LP-430U/430TU/435U/435TU/420S9U/ 420S9TU/425S9U/425S9TU/410U/ 410TU 0 to 6000: 0.000 to 6.000 mm LP-431U/431TU/421S9U/421S9TU/ 411U/411TU 0 to 4000: 0.000 to 4.000 mm		
			n + 24	Laser power offset: 000 to 200%			
			n + 25	Scan speed correction: 005 to 500%			

Contents		F0	F1 (= \$u n)		F2
Counter reset		1 - 8 (PLC1 - 8)	n	Station number: 0 (fixed)	10
			n + 1	Command: A6H	
			n + 2	Counter 0 0: Not reset 1: Reset	
			n + 3	Counter 1 0: Not reset 1: Reset	
			n + 4	Counter 2 0: Not reset 1: Reset	
			n + 5	Counter 3 0: Not reset 1: Reset	
			n + 6	Counter 4 0: Not reset 1: Reset	
			n + 7	Counter 5 0: Not reset 1: Reset	
			n + 8	Counter 6 0: Not reset 1: Reset	
			n + 9	Counter 7 0: Not reset 1: Reset	
Shutter		1 - 8 (PLC1 - 8)	n	Station number: 0 (fixed)	3
			n + 1	Command: A7H	
			n + 2	Shutter status 0: Shutter close 1: Shutter open	
Print trigger		1 - 8 (PLC1 - 8)	n	Station number: 0 (fixed)	3
			n + 1	Command: A8H	
			n + 2	Print command 0: Stop 1: Start	
One-point laser irradiation		1 - 8 (PLC1 - 8)	n	Station number: 0 (fixed)	3
			n + 1	Command: A9H	
			n + 2	0: Stop 1: Start 2: Suspend	
Step & repeat condition	Reading of condition	1 - 8 (PLC1 - 8)	n	Station number: 0 (fixed)	2
			n + 1	Command: 2AH	
			n + 2	Step & repeat 0: None 1: Provided	
			n + 3	Number of lines: 001 to 100	
			n + 4	Number of columns: 001 to 100	
			n + 5 to n + 6	Line step LP-430U/430TU/420S9U/420S9TU/ 410U/410TU 0 to 110000: 000.000 to 110.000 mm LP-431U/431TU/421S9U/421S9TU/ 411U/411TU 0 to 55000: 000.000 to 055.000 mm LP-435U/435TU/425S9U/425S9TU 000 to 160000: 000.000 to 160.000 mm	
			n + 7 to n + 8	Column step	
			n + 9	Counter motion 0000H: Same for all steps 001xH: Unallocated number 002xH: Serial number 00x0H: From top left toward right 00x1H: From top left toward bottom 00x2H: From top right toward left 00x3H: From top right toward bottom	

Contents		F0	F1 (= \$u n)		F2	
Step & repeat condition	Writing of condition	1 - 8 (PLC1 - 8)	n	Station number: 0 (fixed)		10
			n + 1	Command: AAH		
			n + 2	Step & repeat 0: None 1: Provided		
			n + 3	Number of lines: 001 to 100		
			n + 4	Number of columns: 001 to 100		
			n + 5 to n + 6	Line step	LP-430U/430TU/420S9U/420S9TU/ 410U/410TU 0 to 110000: 000.000 to 110.000 mm LP-431U/431TU/421S9U/421S9TU/ 411U/411TU 0 to 55000: 000.000 to 055.000 mm LP-435U/435TU/425S9U/425S9TU 000 to 160000: 000.000 to 160.000 mm	
			n + 7 to n + 8	Column step	LP-430U/430TU/420S9U/420S9TU/ 410U/410TU 0 to 110000: 000.000 to 110.000 mm LP-431U/431TU/421S9U/421S9TU/ 411U/411TU 0 to 55000: 000.000 to 055.000 mm LP-435U/435TU/425S9U/425S9TU 000 to 160000: 000.000 to 160.000 mm	
n + 9	Counter motion 0000H: Same for all steps 001xH: Unallocated number 002xH: Serial number 00x0H: From top left toward right 00x1H: From top left toward bottom 00x2H: From top right toward left 00x3H: From top right toward bottom					
Text condition (abbreviated form)	Reading of text condition (abbreviated form)	1 - 8 (PLC1 - 8)	n	Station number: 0 (fixed)		3
			n + 1	Command: 2BH		
			n + 2	Condition number (01 to 60)		
			n + 3 to n + 4	X position	LP-430U/430TU/420S9U/420S9TU/ 410U/410TU -55000 to +55000: -055.000 to +055.000 mm LP-431U/431TU/421S9U/421S9TU/ 411U/411TU -27500 to +27500: -027.500 to +027.500 mm LP-435U/435TU/425S9U/425S9TU -80000 to +80000: -080.000 to +080.000 mm	
	n + 5 to n + 6	Y position	LP-430U/430TU/420S9U/420S9TU/ 410U/410TU -55000 to +55000: -055.000 to +055.000 mm LP-431U/431TU/421S9U/421S9TU/ 411U/411TU -27500 to +27500: -027.500 to +027.500 mm LP-435U/435TU/425S9U/425S9TU -80000 to +80000: -080.000 to +080.000 mm			
	n + 6 to n + 7	Laser power offset: 000 to 200%				
	Text condition (abbreviated form)	Writing of text condition (abbreviated form)	1 - 8 (PLC1 - 8)	n	Station number: 0 (fixed)	
n + 1				Command: ABH		
n + 2				Condition number (01 to 60)		
n + 3 to n + 4				X position	LP-430U/430TU/420S9U/420S9TU/ 410U/410TU -55000 to +55000: -055.000 to +055.000 mm LP-431U/431TU/421S9U/421S9TU/ 411U/411TU -27500 to +27500: -027.500 to +027.500 mm LP-435U/435TU/425S9U/425S9TU -80000 to +80000: -080.000 to +080.000 mm	
n + 5 to n + 6				Y position	LP-430U/430TU/420S9U/420S9TU/ 410U/410TU -55000 to +55000: -055.000 to +055.000 mm LP-431U/431TU/421S9U/421S9TU/ 411U/411TU -27500 to +27500: -027.500 to +027.500 mm LP-435U/435TU/425S9U/425S9TU -80000 to +80000: -080.000 to +080.000 mm	
n + 6 to n + 7				Laser power offset: 000 to 200%		

Contents		F0	F1 (= \$u n)		F2				
Reading of barcode print condition	QR code	1 to 8 (PLC1 to 8)	n	Station number: 0 (fixed)		3			
			n+1	Command: 2CH					
			n+2	Barcode number: 0 to 7					
			n+3	Area number: 0 to FH					
			n+4	Type 10: Model 1 11: Model 2 12: Micro QR					
			n+5	Version Model 1: 0 to 14 Model 2: 0 to 22 Micro QR: 0 to 4					
			n+6	Data input mode 0: Numerals 1: Alphanumerics 2: Binary 3: Kanji characters					
			n+7	Error correction level 1: Standard 2: High reliability 3: Ultra-high reliability					
			n+8 to n+9	X position	LP-430U/430TU/420S9U/420S9TU/410U/410TU -55000 to +55000: -055.000 to +055.000 mm LP-431U/431TU/421S9U/421S9TU/411U/411TU -27500 to +27500: -027.500 to +027.500 mm				
			n+10 to n+11	Y position	LP-435U/435TU/425S9U/425S9TU -80000 to +80000: -080.000 to +080.000 mm				
			n+12 to n+13	Rotation angle -18000 to +18000: -180.00 to +180.00 deg					
			n+14	Module pitch: vertical 0050 to 1000: 0.050 to 1.000 mm					
			n+15	Module pitch: horizontal 0050 to 1000: 0.050 to 1.000 mm					
			Data matrix code (ECC200)	1 to 8 (PLC1 to 8)	n		Station number: 0 (fixed)		3
					n+1		Command: 2CH		
	n+2	Barcode number: 0 to 7							
	n+3	Area number: 0 to FH							
	n+4	Type 20: Data matrix							
	n+5	Data input mode 0: 1-byte 1: Kanji characters							
	n+6	Number of rows							
n+7	Number of columns								
n+8 to n+9	X position	LP-430U/430TU/420S9U/420S9TU/410U/410TU -55000 to +55000: -055.000 to +055.000 mm LP-431U/431TU/421S9U/421S9TU/411U/411TU -27500 to +27500: -027.500 to +027.500 mm							
n+10 to n+11	Y position	LP-435U/435TU/425S9U/425S9TU -80000 to +80000: -080.000 to +080.000 mm							
n+12 to n+13	Rotation angle -18000 to +18000: -180.00 to +180.00 deg								
n+14	Module pitch: vertical 0050 to 1000: 0.050 to 1.000 mm								
n+15	Module pitch: horizontal 0050 to 1000: 0.050 to 1.000 mm								

Contents		F0	F1 (= \$u n)		F2			
Reading of barcode print condition	CODE39 ITF NW-7	1 to 8 (PLC1 to 8)	n	Station number: 0 (fixed)	3			
			n+1	Command: 2CH				
			n+2	Barcode number: 0 to 7				
			n+3	Area number: 0 to FH				
			n+4	Type 00: CODE39 01: ITF 03: NW-7				
			n+5	Inversion 0: Invalid 1: Valid				
			n+6	Check character CODE39, ITF 0: No 1: Yes NW-7 A to D: Without check character a to d: With check character				
			n+7 to n+8	Height LP-430U/430TU/420S9U/420S9TU/ 410U/410TU 001000 to 110000: 001.000 to 110.000 mm LP-431U/431TU/421S9U/421S9TU/ 411U/411TU 001000 to 055000: 001.000 to 055.000 mm LP-435U/435TU/425S9U/425S9TU 001000 to 160000: 001.000 to 160.000 mm				
			n+9	Narrow element width 0050 to 1000: 0.050 to 1.000 mm				
			n+10 to n+11	X position LP-430U/430TU/420S9U/420S9TU/ 410U/410TU -55000 to +55000: -055.000 to +055.000 mm LP-431U/431TU/421S9U/421S9TU/ 411U/411TU -27500 to +27500: -027.500 to +027.500 mm LP-435U/435TU/425S9U/425S9TU -80000 to +80000: -080.000 to +080.000 mm				
			n+12 to n+13	Y position LP-430U/430TU/420S9U/420S9TU/ 410U/410TU -27500 to +27500: -027.500 to +027.500 mm LP-435U/435TU/425S9U/425S9TU -80000 to +80000: -080.000 to +080.000 mm				
			n+14 to n+15	Tilting angle -18000 to +18000: -180.00 to +180.00 deg				
			n+16	Ratio quiet zone/narrow element 000 to 200: 00.0 to 20.0				
			n+17	Ratio wide element width/narrow element width 18 to 34: 1.8 to 3.4				
			n+18	Laser power correction: 0 to 200%				
			n+19	Scan speed correction: 5 to 500%				
			CODE128 JAN	1 to 8 (PLC1 to 8)		n	Station number: 0 (fixed)	3
						n+1	Command: 2CH	
						n+2	Barcode number: 0 to 7	
	n+3	Area number: 0 to FH						
n+4	Type 02: CODE128 04: JAN/UPC 08: JAN/UPC with human-readable string 09: CODE128 with human-readable string							
n+5	Inversion 0: Invalid 1: Valid							
n+6	Check character 0: No 1: Yes							

Contents		F0	F1 (= \$u n)		F2	
Reading of barcode print condition	CODE128 JAN	1 to 8 (PLC1 to 8)	n+7 to n+8	Height	LP-430U/430TU/420S9U/420S9TU/410U/410TU 001000 to 110000: 001.000 to 110.000 mm LP-431U/431TU/421S9U/421S9TU/411U/411TU 001000 to 055000: 001.000 to 055.000 mm LP-435U/435TU/425S9U/425S9TU 001000 to 160000: 001.000 to 160.000 mm	3
			n+9	Narrow element width 0050 to 1000: 0.050 to 1.000 mm		
			n+10 to n+11	X position	LP-430U/430TU/420S9U/420S9TU/410U/410TU -55000 to +55000: -055.000 to +055.000 mm LP-431U/431TU/421S9U/421S9TU/411U/411TU -27500 to +27500: -027.500 to +027.500 mm LP-435U/435TU/425S9U/425S9TU -80000 to +80000: -080.000 to +080.000 mm	
			n+12 to n+13	Y position		
			n+14 to n+15	Tilting angle -18000 to +18000: -180.00 to +180.00 deg		
			n+16	Ratio quiet zone/narrow element 000 to 200: 00.0 to 20.0		
			n+17	Ratio double width/narrow element width 14 to 26: 1.4 to 2.6		
			n+18	Ratio triple width/narrow element width 21 to 39: 2.1 to 3.9		
			n+19	Ratio quadruple width/narrow element width 28 to 52: 2.8 to 5.2		
			n+20	Laser power correction: 0 to 200%		
	n+21	Scan speed correction: 5 to 500%				
	RSS-14 Standard & Truncated RSS Limited RSS Expanded	1 to 8 (PLC1 to 8)	n	Station number: 0 (fixed)		3
			n+1	Command: 2CH		
			n+2	Barcode number: 0 to 7		
			n+3	Area number: 0 to FH		
			n+4	Type 30: RSS-14 Standard & Truncated 33: RSS Limited 34: RSS Expanded 40: RSS-14 Standard & Truncated CC-A 43: RSS Limited CC-A 44: RSS Expanded CC-A 50: RSS-14 Standard & Truncated CC-B 53: RSS Limited CC-B 54: RSS Expanded CC-B		
			n+5	Human-readable string 0: Without human-readable string 2: With human-readable string		
			n+6	Inversion 0: Invalid 1: Valid 2: Valid (with guard pattern)		
			n+7 to n+8	Height	LP-430U/430TU/420S9U/420S9TU/410U/410TU 001000 to 110000: 001.000 to 110.000 mm LP-431U/431TU/421S9U/421S9TU/411U/411TU 001000 to 055000: 001.000 to 055.000 mm LP-435U/435TU/425S9U/425S9TU 001000 to 160000: 001.000 to 160.000 mm	
			n+9	Standard module width 0050 to 1000: 0.050 to 1.000 mm		

Contents		F0	F1 (= \$u n)			F2	
Reading of barcode print condition	RSS-14 Standard & Truncated RSS Limited RSS Expanded	1 to 8 (PLC1 to 8)	n+10 to n+11	X position	LP-430U/430TU/420S9U/420S9TU/410U/410TU -55000 to +55000: -055.000 to +055.000 mm	3	
			n+12 to n+13	Y position	LP-431U/431TU/421S9U/421S9TU/411U/411TU -27500 to +27500: -027.500 to +027.500 mm		
			n+14 to n+15	Tilting angle -18000 to +18000: -180.00 to +180.00 deg			
			n+16	Laser power correction: 0 to 200%			
			n+17	Scan speed correction: 5 to 500%			
	RSS-14 Stacked RSS-14 Stacked Omnidirectional	1 to 8 (PLC1 to 8)	n	Station number: 0 (fixed)			3
			n+1	Command: 2CH			
			n+2	Barcode number: 0 to 7			
			n+3	Area number: 0 to FH			
			n+4	Type 31: RSS-14 Stacked 32: RSS-14 Stacked Omnidirectional 41: RSS-14 Stacked CC-A 42: RSS-14 Stacked Omnidirectional CC-A 51: RSS-14 Stacked CC-B 52: RSS-14 Stacked Omnidirectional CC-B			
			n+5	Human-readable string 0: Without human-readable string 2: With human-readable string			
			n+6	Inversion 0: Invalid 1: Valid 2: Valid (with guard pattern)			
			n+7 to n+8	Barcode 1-stack height	LP-430U/430TU/420S9U/420S9TU/410U/410TU 001000 to 110000: 001.000 to 110.000 mm LP-431U/431TU/421S9U/421S9TU/411U/411TU 001000 to 055000: 001.000 to 055.000 mm LP-435U/435TU/425S9U/425S9TU 001000 to 160000: 001.000 to 160.000 mm		
			n+9	Separator height (W) ratio 000 to 100: 00.0 to 10.0 mm			
			n+10	Standard module width 0050 to 1000: 0.050 to 1.000 mm			
			n+11 to n+12	X position	LP-430U/430TU/420S9U/420S9TU/410U/410TU -55000 to +55000: -055.000 to +055.000 mm		
			n+13 to n+14	Y position	LP-431U/431TU/421S9U/421S9TU/411U/411TU -27500 to +27500: -027.500 to +027.500 mm LP-435U/435TU/425S9U/425S9TU -80000 to +80000: -080.000 to +080.000 mm		
			n+15 to n+16	Tilting angle -18000 to +18000: -180.00 to +180.00 deg			
			n+17	Laser power correction: 0 to 200%			
			n+18	Scan speed correction: 5 to 500%			

Contents		F0	F1 (= \$u n)		F2	
Reading of barcode print condition	RSS-14 Expanded Stacked	1 to 8 (PLC1 to 8)	n	Station number: 0 (fixed)		3
			n+1	Command: 2CH		
			n+2	Barcode number: 0 to 7		
			n+3	Area number: 0 to FH		
			n+4	Type 35: RSS Expanded Stacked 45: RSS Expanded Stacked CC-A 55: RSS Expanded Stacked CC-B		
			n+5	Human-readable string 0: Without human-readable string 2: With human-readable string		
			n+6	Inversion 0: Invalid 1: Valid 2: Valid (with guard pattern)		
			n+7 to n+8	Barcode 1-stack height	LP-430U/430TU/420S9U/420S9TU/410U/410TU 001000 to 110000: 001.000 to 110.000 mm LP-431U/431TU/421S9U/421S9TU/411U/411TU 001000 to 055000: 001.000 to 055.000 mm LP-435U/435TU/425S9U/425S9TU 001000 to 160000: 001.000 to 160.000 mm	
			n+9	Separator height (W) ratio 000 to 100: 00.0 to 10.0 mm		
			n+10	Number of horizontal symbol characters: 2 to 20 (even)		
	n+11	Standard module width 0050 to 1000: 0.050 to 1.000 mm				
	n+12 to n+13	X position	LP-430U/430TU/420S9U/420S9TU/410U/410TU -55000 to +55000: -055.000 to +055.000 mm LP-431U/431TU/421S9U/421S9TU/411U/411TU -27500 to +27500: -027.500 to +027.500 mm			
	n+14 to n+15	Y position	LP-435U/435TU/425S9U/425S9TU -80000 to +80000: -080.000 to +080.000 mm			
	n+16 to n+17	Tilting angle -18000 to +18000: -180.00 to +180.00 deg				
	n+18	Laser power correction: 0 to 200%				
	n+19	Scan speed correction: 5 to 500%				
	Composite	1 to 8 (PLC1 to 8)	n	Station number: 0 (fixed)		3
			n+1	Command: 2CH		
			n+2	Barcode number: 0 to 7		
			n+3	Area number: 0 to FH		
n+4			Type CC-A composite 46: JAN/UPC 47: UCC/EAN128 48: JAN/UPC with 1D human-readable string 49: UCC/EAN128 with 1D human-readable string CC-B composite 56: JAN/UPC 57: UCC/EAN128 58: JAN/UPC with 1D human-readable string 59: UCC/EAN128 with 1D human-readable string CC-C composite 67: UCC/EAN128 69: UCC/EAN128 with 1D human-readable string			
n+5			Human-readable string 0: Without human-readable string 2: With human-readable string			
n+6			Inversion 0: Invalid 1: Valid			

Contents		F0	F1 (= \$u n)		F2	
Reading of barcode print condition	Composite	1 to 8 (PLC1 to 8)	n+7 to n+8	Barcode 1-stack height	LP-430U/430TU/420S9U/420S9TU/ 410U/410TU 001000 to 110000: 001.000 to 110.000 mm LP-431U/431TU/421S9U/421S9TU/ 411U/411TU 001000 to 055000: 001.000 to 055.000 mm LP-435U/435TU/425S9U/425S9TU 001000 to 160000: 001.000 to 160.000 mm	3
			n+9	Narrow element width 0050 to 1000: 0.050 to 1.000 mm		
			n+10 to n+11	X position	LP-430U/430TU/420S9U/420S9TU/ 410U/410TU -55000 to +55000: -055.000 to +055.000 mm LP-431U/431TU/421S9U/421S9TU/ 411U/411TU -27500 to +27500: -027.500 to +027.500 mm LP-435U/435TU/425S9U/425S9TU -80000 to +80000: -080.000 to +080.000 mm	
			n+12 to n+13	Y position		
			n+14 to n+15	Tilting angle -18000 to +18000: -180.00 to +180.00 deg		
			n+16	Ratio quiet zone/narrow element 000 to 200: 00.0 to 20.0		
			n+17	Laser power correction: 0 to 200%		
			n+18	Scan speed correction: 5 to 500%		
Writing of barcode print condition	QR code	1 to 8 (PLC1 to 8)	n	Station number: 0 (fixed)		16
			n+1	Command: ACH		
			n+2	Barcode number: 0 to 7		
			n+3	Area number: 0 to FH		
			n+4	Type 10: Model 1 11: Model 2 12: Micro QR		
			n+5	Version Model 1: 0 to 14 Model 2: 0 to 22 Micro QR: 0 to 4		
			n+6	Data input mode 0: Numerals 1: Alphanumerics 2: Binary 3: Kanji characters		
			n+7	Error correction level 0: High density 1: Standard 2: High reliability 3: Ultra-high reliability		
			n+8 to n+9	X position	LP-430U/430TU/420S9U/420S9TU/ 410U/410TU -55000 to +55000: -055.000 to +055.000 mm LP-431U/431TU/421S9U/421S9TU/ 411U/411TU -27500 to +27500: -027.500 to +027.500 mm LP-435U/435TU/425S9U/425S9TU -80000 to +80000: -080.000 to +080.000 mm	
			n+10 to n+11	Y position		
			n+12 to n+13	Rotation angle -18000 to +18000: -180.00 to +180.00 deg		
			n+14	Module pitch: vertical 0050 to 1000: 0.050 to 1.000 mm		
n+15	Module pitch: horizontal 0050 to 1000: 0.050 to 1.000 mm					

Contents		F0	F1 (= \$u n)		F2	
Writing of barcode print condition	Data matrix code (ECC200)	1 to 8 (PLC1 to 8)	n	Station number: 0 (fixed)	16	
			n+1	Command: ACH		
			n+2	Barcode number: 0 to 7		
			n+3	Area number: 0 to FH		
			n+4	Type 20: Data matrix		
			n+5	Data input mode 0: 1-byte 1: Kanji characters		
			n+6	Number of rows		
			n+7	Number of columns		
			n+8 to n+9	X position		LP-430U/430TU/420S9U/420S9TU/410U/410TU -55000 to +55000: -055.000 to +055.000 mm LP-431U/431TU/421S9U/421S9TU/411U/411TU
			n+10 to n+11	Y position		-27500 to +27500: -027.500 to +027.500 mm LP-435U/435TU/425S9U/425S9TU -80000 to +80000: -080.000 to +080.000 mm
			n+12 to n+13	Rotation angle		-18000 to +18000: -180.00 to +180.00 deg
			n+14	Module pitch: vertical		0050 to 1000: 0.050 to 1.000 mm
			n+15	Module pitch: horizontal		0050 to 1000: 0.050 to 1.000 mm
			CODE39 ITF NW-7	1 to 8 (PLC1 to 8)		n
	n+1	Command: ACH				
	n+2	Barcode number: 0 to 7				
	n+3	Area number: 0 to FH				
	n+4	Type 00: CODE39 01: ITF 03: NW-7				
	n+5	Inversion 0: Invalid 1: Valid				
	n+6	Check character CODE39, ITF 0: No 1: Yes NW-7 A to D: Without check character a to d: With check character				
n+7 to n+8	Height	LP-430U/430TU/420S9U/420S9TU/410U/410TU 001000 to 110000: 001.000 to 110.000 mm LP-431U/431TU/421S9U/421S9TU/411U/411TU 001000 to 055000: 001.000 to 055.000 mm LP-435U/435TU/425S9U/425S9TU 001000 to 160000: 001.000 to 160.000 mm				
n+9	Narrow element width	0050 to 1000: 0.050 to 1.000 mm				
n+10 to n+11	X position	LP-430U/430TU/420S9U/420S9TU/410U/410TU -55000 to +55000: -055.000 to +055.000 mm LP-431U/431TU/421S9U/421S9TU/411U/411TU				
n+12 to n+13	Y position	-27500 to +27500: -027.500 to +027.500 mm LP-435U/435TU/425S9U/425S9TU -80000 to +80000: -080.000 to +080.000 mm				

Contents		F0	F1 (= \$u n)		F2		
Writing of barcode print condition	CODE39 ITF NW-7	1 to 8 (PLC1 to 8)	n+14 to n+15	Tilting angle -18000 to +18000: -180.00 to +180.00 deg		20	
			n+16	Ratio quiet zone/narrow element 000 to 200: 00.0 to 20.0			
			n+17	Ratio wide element width/narrow element width 18 to 34: 1.8 to 3.4			
			n+18	Laser power correction: 0 to 200%			
			n+19	Scan speed correction: 5 to 500%			
	CODE128 JAN	1 to 8 (PLC1 to 8)	n	Station number: 0 (fixed)		22	
			n+1	Command: ACH			
			n+2	Barcode number: 0 to 7			
			n+3	Area number: 0 to FH			
			n+4	Type 02: CODE128 04: JAN 08: JAN/UPC with human-readable string 09: CODE128 with human-readable string			
			n+5	Inversion 0: Invalid 1: Valid			
			n+6	Check character 0: No 1: Yes			
			n+7 to n+8	Height	LP-430U/430TU/420S9U/420S9TU/ 410U/410TU 001000 to 110000: 001.000 to 110.000 mm LP-431U/431TU/421S9U/421S9TU/ 411U/411TU 001000 to 055000: 001.000 to 055.000 mm LP-435U/435TU/425S9U/425S9TU 001000 to 160000: 001.000 to 160.000 mm		
			n+9	Narrow element width 0050 to 1000: 0.050 to 1.000 mm			
			n+10 to n+11	X position	LP-430U/430TU/420S9U/420S9TU/ 410U/410TU -55000 to +55000: -055.000 to +055.000 mm LP-431U/431TU/421S9U/421S9TU/ 411U/411TU -27500 to +27500: -027.500 to +027.500 mm LP-435U/435TU/425S9U/425S9TU -80000 to +80000: -080.000 to +080.000 mm		
			n+12 to n+13	Y position			
			n+14 to n+15	Tilting angle -18000 to +18000: -180.00 to +180.00 deg			
			n+16	Ratio quiet zone/narrow element 000 to 200: 00.0 to 20.0			
			n+17	Ratio double width/narrow element width 14 to 26: 1.4 to 2.6			
			n+18	Ratio triple width/narrow element width 21 to 39: 2.1 to 3.9			
			n+19	Ratio quadruple width/narrow element width 28 to 52: 2.8 to 5.2			
n+20	Laser power correction: 0 to 200%						
n+21	Scan speed correction: 5 to 500%						

Contents		F0	F1 (= \$u n)		F2				
Writing of barcode print condition	RSS-14 Standard & Truncated RSS Limited RSS Expanded	1 to 8 (PLC1 to 8)	n	Station number: 0 (fixed)		18			
			n+1	Command: ACH					
			n+2	Barcode number: 0 to 7					
			n+3	Area number: 0 to FH					
			n+4	Type 30: RSS-14 Standard & Truncated 33: RSS Limited 34: RSS Expanded 40: RSS-14 Standard & Truncated CC-A 43: RSS Limited CC-A 44: RSS Expanded CC-A 50: RSS-14 Standard & Truncated CC-B 53: RSS Limited CC-B 54: RSS Expanded CC-B					
			n+5	Human-readable string 0: Without human-readable string 2: With human-readable string					
			n+6	Inversion 0: Invalid 1: Valid 2: Valid (with guard pattern)					
			n+7 to n+8	Height	LP-430U/430TU/420S9U/420S9TU/ 410U/410TU 001000 to 110000: 001.000 to 110.000 mm LP-431U/431TU/421S9U/421S9TU/ 411U/411TU 001000 to 055000: 001.000 to 055.000 mm LP-435U/435TU/425S9U/425S9TU 001000 to 160000: 001.000 to 160.000 mm				
			n+9	Standard module width 0050 to 1000: 0.050 to 1.000 mm					
			n+10 to n+11	X position	LP-430U/430TU/420S9U/420S9TU/ 410U/410TU -55000 to +55000: -055.000 to +055.000 mm LP-431U/431TU/421S9U/421S9TU/ 411U/411TU -27500 to +27500: -027.500 to +027.500 mm LP-435U/435TU/425S9U/425S9TU -80000 to +80000: -080.000 to +080.000 mm				
			n+12 to n+13	Y position					
			n+14 to n+15	Tilting angle -18000 to +18000: -180.00 to +180.00 deg					
			n+16	Laser power correction: 0 to 200%					
			n+17	Scan speed correction: 5 to 500%					
			RSS-14 Stacked RSS-14 Stacked Omnidirectional	1 to 8 (PLC1 to 8)	n		Station number: 0 (fixed)		19
					n+1		Command: ACH		
					n+2		Barcode number: 0 to 7		
n+3	Area number: 0 to FH								
n+4	Type 31: RSS-14 Stacked 32: RSS-14 Stacked Omnidirectional 41: RSS-14 Stacked CC-A 42: RSS-14 Stacked Omnidirectional CC-A 51: RSS-14 Stacked CC-B 52: RSS-14 Stacked Omnidirectional CC-B								
n+5	Human-readable string 0: Without human-readable string 2: With human-readable string								
n+6	Inversion 0: Invalid 1: Valid 2: Valid (with guard pattern)								

Contents		F0	F1 (= \$u n)		F2		
Writing of barcode print condition	RSS-14 Stacked	1 to 8 (PLC1 to 8)	n+7 to n+8	Barcode 1-stack height	LP-430U/430TU/420S9U/420S9TU/410U/410TU 001000 to 110000: 001.000 to 110.000 mm LP-431U/431TU/421S9U/421S9TU/411U/411TU 001000 to 055000: 001.000 to 055.000 mm LP-435U/435TU/425S9U/425S9TU 001000 to 160000: 001.000 to 160.000 mm	19	
	RSS-14 Stacked Omnidirectional		n+9	Separator height (W) ratio 000 to 100: 00.0 to 10.0 mm			
			n+10	Standard module width 0050 to 1000: 0.050 to 1.000 mm			
			n+11 to n+12	X position	LP-430U/430TU/420S9U/420S9TU/410U/410TU -55000 to +55000: -055.000 to +055.000 mm LP-431U/431TU/421S9U/421S9TU/411U/411TU -27500 to +27500: -027.500 to +027.500 mm LP-435U/435TU/425S9U/425S9TU -80000 to +80000: -080.000 to +080.000 mm		
			n+13 to n+14	Y position			
			n+15 to n+16	Tilting angle -18000 to +18000: -180.00 to +180.00 deg			
			n+17	Laser power correction: 0 to 200%			
			n+18	Scan speed correction: 5 to 500%			
			n	Station number: 0 (fixed)		20	
			n+1	Command: ACH			
			n+2	Barcode number: 0 to 7			
			n+3	Area number: 0 to FH			
			n+4	Type 35: RSS Expanded Stacked 45: RSS Expanded Stacked CC-A 55: RSS Expanded Stacked CC-B			
			n+5	Human-readable string 0: Without human-readable string 2: With human-readable string			
			n+6	Inversion 0: Invalid 1: Valid 2: Valid (with guard pattern)			
			RSS-14 Expanded Stacked	n+7 to n+8	Barcode 1-stack height		LP-430U/430TU/420S9U/420S9TU/410U/410TU 001000 to 110000: 001.000 to 110.000 mm LP-431U/431TU/421S9U/421S9TU/411U/411TU 001000 to 055000: 001.000 to 055.000 mm LP-435U/435TU/425S9U/425S9TU 001000 to 160000: 001.000 to 160.000 mm
				n+9	Separator height (W) ratio 000 to 100: 00.0 to 10.0 mm		
				n+10	Number of horizontal symbol characters: 2 to 20 (even)		
		n+11	Standard module width 0050 to 1000: 0.050 to 1.000 mm				
		n+12 to n+13	X position	LP-430U/430TU/420S9U/420S9TU/410U/410TU -55000 to +55000: -055.000 to +055.000 mm LP-431U/431TU/421S9U/421S9TU/411U/411TU -27500 to +27500: -027.500 to +027.500 mm LP-435U/435TU/425S9U/425S9TU -80000 to +80000: -080.000 to +080.000 mm			
		n+14 to n+15	Y position				

Contents		F0	F1 (= \$u n)		F2	
Writing of barcode print condition	RSS-14 Expanded Stacked	1 to 8 (PLC1 to 8)	n+16 to n+17	Tilting angle -18000 to +18000: -180.00 to +180.00 deg		20
			n+18	Laser power correction: 0 to 200%		
			n+19	Scan speed correction: 5 to 500%		
	Composite	1 to 8 (PLC1 to 8)	n	Station number: 0 (fixed)		19
			n+1	Command: ACH		
			n+2	Barcode number: 0 to 7		
			n+3	Area number: 0 to FH		
			n+4	Type CC-A composite 46: JAN/UPC 47: UCC/EAN128 48: JAN/UPC with 1D human-readable string 49: UCC/EAN128 with 1D human-readable string CC-B composite 56: JAN/UPC 57: UCC/EAN128 58: JAN/UPC with 1D human-readable string 59: UCC/EAN128 with 1D human-readable string CC-C composite 67: UCC/EAN128 69: UCC/EAN128 with 1D human-readable string		
			n+5	Human-readable string 0: Without human-readable string 2: With human-readable string		
			n+6	Inversion 0: Invalid 1: Valid		
			n+7 to n+8	Barcode 1-stack height	LP-430U/430TU/420S9U/420S9TU/ 410U/410TU 001000 to 110000: 001.000 to 110.000 mm LP-431U/431TU/421S9U/421S9TU/ 411U/411TU 001000 to 055000: 001.000 to 055.000 mm LP-435U/435TU/425S9U/425S9TU 001000 to 160000: 001.000 to 160,000 mm	
			n+9	Narrow element width 0050 to 1000: 0.050 to 1.000 mm		
			n+10 to n+11	X position	LP-430U/430TU/420S9U/420S9TU/ 410U/410TU -55000 to +55000: -055.000 to +055.000 mm LP-431U/431TU/421S9U/421S9TU/ 411U/411TU	
			n+12 to n+13	Y position	-27500 to +27500: -027.500 to +027.500 mm LP-435U/435TU/425S9U/425S9TU -80000 to +80000: -080.000 to +080.000 mm	
			n+14 to n+15	Tilting angle -18000 to +18000: -180.00 to +180.00 deg		
			n+16	Ratio quiet zone/narrow element 000 to 200: 00.0 to 20.0		
			n+17	Laser power correction: 0 to 200%		
			n+18	Scan speed correction: 5 to 500%		
Barcode print data (2-byte characters)	Reading of barcode print data	1 to 8 (PLC1 to 8)	n	Station number: 0 (fixed)		4
			n+1	Command: 2DH		
			n+2	Barcode number: 0 to 7		
			n+3	Set row number (2-D code): 1 to 9		
	Writing of barcode print data	1 to 8 (PLC1 to 8)	n	Station number: 0 (fixed)		4 + print data word count (30 words maximum)
			n+1	Command: ADH		
			n+2	Barcode number: 0 to 7		
			n+3	Set row number (2-D code): 1 to 9		
n+4 to n+33	Print data					

Contents		F0	F1 (= \$u n)		F2		
2-D code pattern	Reading of 2-D code pattern	1 to 8 (PLC1 to 8)	n	Station number: 0 (fixed)		4	
			n+1	Command: 2EH			
			n+2	Barcode number: 0 to 7			
			n+3	Pattern number For QR code 0: Quite zone/margin 1: Black module 2: White module 3: Alignment 4: Finder For data matrix code 0: Quite zone/margin 1: Mark module 2: Space module			
			n+4	Character code (DEC) 0000, 2230 to 2239, 8121 to 8152			
			n+5	Laser power correction: 0 to 200%			
			n+6	Scan speed correction: 5 to 500%			
	Writing of 2-D code pattern	1 to 8 (PLC1 to 8)	n	Station number: 0 (fixed)		7	
			n+1	Command: AEH			
			n+2	Barcode number: 0 to 7			
			n+3	Pattern number For QR code 0: Quite zone/margin 1: Black module 2: White module 3: Alignment 4: Finder For data matrix code 0: Quite zone/margin 1: Mark module 2: Space module			
			n+4	Character code (DEC) 0000, 2230 to 2239, 8121 to 8152			
			n+5	Laser power correction: 0 to 200%			
			n+6	Scan speed correction: 5 to 500%			
Serial data input		1 to 8 (PLC1 to 8)	n	Station number: 0 (fixed)		3 + data word count (128 words maximum)	
			n+1	Command: AFH			
			n+2	Serial data number: 0 to 15			
			n+3 to n+130	Data			
Processing condition setting	Reading of processing condition	1 to 8 (PLC1 to 8)	n	Station number: 0 (fixed)		3	
			n+1	Command: 30H			
			n+2	Processing condition number: 0 to 7			
			n+3	Area number: 0 to FH			
			n+4 to n+5	X offset	LP-430U/430TU/420S9U/420S9TU/410U/410TU -55000 to +55000: -055.000 to +055.000 mm LP-431U/431TU/421S9U/421S9TU/411U/411TU -27500 to +27500: -027.500 to +027.500 mm LP-435U/435TU/425S9U/425S9TU -80000 to +80000: -080.000 to +080.000 mm		
			n+6 to n+7	Y offset			
			n+8	Rotation angle -18000 to +18000: -180.00 to +180.00 deg			
			n+9	Laser power correction: 0 to 200%			
			n+10	Scan speed correction: 5 to 500%			

Contents		F0	F1 (= \$u n)		F2					
Processing condition setting	Writing of processing condition	1 to 8 (PLC1 to 8)	n	Station number: 0 (fixed)		12				
			n+1	Command: B0H						
			n+2	Processing condition number: 0 to 7						
			n+3	Area number: 0 to FH						
			n+4 to n+5	X offset	LP-430U/430TU/420S9U/420S9TU/410U/410TU -55000 to +55000: -055.000 to +055.000 mm LP-431U/431TU/421S9U/421S9TU/411U/411TU -27500 to +27500: -027.500 to +027.500 mm					
			n+6 to n+7	Y offset	LP-435U/435TU/425S9U/425S9TU -80000 to +80000: -080.000 to +080.000 mm					
			n+8 to n+9	Rotation angle -18000 to +18000: -180.00 to +180.00 deg						
			n+10	Laser power correction: 0 to 200%						
			n+11	Scan speed correction: 5 to 500%						
			Processing element setting	Reading of processing element setting (straight)	1 to 8 (PLC1 to 8)		n	Station number: 0 (fixed)		4
							n+1	Command: 31H		
n+2	Processing condition number: 0 to 7									
n+3	Processing element number: 0 to 31									
n+4	Element type 0: Straight									
n+5 to n+6	Start point X coordinate	LP-430U/430TU/420S9U/420S9TU/410U/410TU -55000 to +55000: -055.000 to +055.000 mm LP-431U/431TU/421S9U/421S9TU/411U/411TU -27500 to +27500: -027.500 to +027.500 mm								
n+7 to n+8	Start point Y coordinate	LP-435U/435TU/425S9U/425S9TU -80000 to +80000: -080.000 to +080.000 mm								
n+9 to n+10	End point X coordinate	LP-430U/430TU/420S9U/420S9TU/410U/410TU -55000 to +55000: -055.000 to +055.000 mm LP-431U/431TU/421S9U/421S9TU/411U/411TU -27500 to +27500: -027.500 to +027.500 mm								
n+11 to n+12	End point Y coordinate	LP-435U/435TU/425S9U/425S9TU -80000 to +80000: -080.000 to +080.000 mm								
n+13 to n+14	Dashed line: dash length	LP-430U/430TU/420S9U/420S9TU/410U/410TU 000010 to 110000: 000.010 to 110.000 mm LP-431U/431TU/421S9U/421S9TU/411U/411TU 000010 to 550000: 000.010 to 055.000 mm LP-435U/435TU/425S9U/425S9TU 000010 to 160000: 000.010 to 160.000 mm								
n+15 to n+16	Dashed line: space length	LP-430U/430TU/420S9U/420S9TU/410U/410TU 000000 to 110000: 000.000 to 110.000 mm LP-431U/431TU/421S9U/421S9TU/411U/411TU 000000 to 550000: 000.000 to 055.000 mm LP-435U/435TU/425S9U/425S9TU 000000 to 160000: 000.000 to 160.000 mm								

Contents		F0	F1 (= \$u n)		F2	
Processing element setting	Reading of processing element setting (circle)	1 to 8 (PLC1 to 8)	n	Station number: 0 (fixed)		4
			n+1	Command: 31H		
			n+2	Processing condition number: 0 to 7		
			n+3	Processing element number: 0 to 31		
			n+4	Element type 1: Circle		
			n+5 to n+6	Center X coordinate	LP-430U/430TU/420S9U/420S9TU/410U/410TU -55000 to +55000: -055.000 to +055.000 mm LP-431U/431TU/421S9U/421S9TU/411U/411TU	
			n+7 to n+8	Center Y coordinate	-27500 to +27500: -027.500 to +027.500 mm LP-435U/435TU/425S9U/425S9TU -80000 to +80000: -080.000 to +080.000 mm	
			n+9 to n+10	Radius	LP-430U/430TU/420S9U/420S9TU/410U/410TU 000010 to 110000: 000.010 to 110.000 mm LP-431U/431TU/421S9U/421S9TU/411U/411TU	
			n+11 to n+12	Dashed line: dash length	000010 to 550000: 000.010 to 055.000 mm LP-435U/435TU/425S9U/425S9TU 000010 to 160000: 000.010 to 160.000 mm	
			n+13 to n+14	Dashed line: space length	LP-430U/430TU/420S9U/420S9TU/410U/410TU 000000 to 110000: 000.000 to 110.000 mm LP-431U/431TU/421S9U/421S9TU/411U/411TU 000000 to 550000: 000.000 to 055.000 mm LP-435U/435TU/425S9U/425S9TU 000000 to 160000: 000.000 to 160.000 mm	
	Reading of processing element setting (arc)	1 to 8 (PLC1 to 8)	n	Station number: 0 (fixed)		4
			n+1	Command: 31H		
			n+2	Processing condition number: 0 to 7		
			n+3	Processing element number: 0 to 31		
			n+4	Element type 2: Arc		
			n+5 to n+6	Start point X coordinate	LP-430U/430TU/420S9U/420S9TU/410U/410TU -55000 to +55000: -055.000 to +055.000 mm LP-431U/431TU/421S9U/421S9TU/411U/411TU	
			n+7 to n+8	Start point Y coordinate	-27500 to +27500: -027.500 to +027.500 mm LP-435U/435TU/425S9U/425S9TU -80000 to +80000: -080.000 to +080.000 mm	
			n+9 to n+10	End point X coordinate	LP-430U/430TU/420S9U/420S9TU/410U/410TU -55000 to +55000: -055.000 to +055.000 mm LP-431U/431TU/421S9U/421S9TU/411U/411TU	
			n+11 to n+12	End point Y coordinate	-27500 to +27500: -027.500 to +027.500 mm LP-435U/435TU/425S9U/425S9TU -80000 to +80000: -080.000 to +080.000 mm	
			n+13 to n+14	Radius	000010 to 300000: 000.010 to 300.000 mm	
n+15	Drawing direction 0: Counterclockwise 1: Clockwise					
n+16	Center angle 0: Less than 180 deg 1: 180 deg or more					

Contents		F0	F1 (= \$u n)		F2	
Processing element setting	Reading of processing element setting (arc)	1 to 8 (PLC1 to 8)	n+17 to n+18	Dashed line: dash length	LP-430U/430TU/420S9U/420S9TU/410U/410TU 000010 to 110000: 000.010 to 110.000 mm LP-431U/431TU/421S9U/421S9TU/411U/411TU 000010 to 550000: 000.010 to 055.000 mm LP-435U/435TU/425S9U/425S9TU 000010 to 160000: 000.010 to 160.000 mm	4
			n+19 to n+20	Dashed line: space length	LP-430U/430TU/420S9U/420S9TU/410U/410TU 000000 to 110000: 000.000 to 110.000 mm LP-431U/431TU/421S9U/421S9TU/411U/411TU 000000 to 550000: 000.000 to 055.000 mm LP-435U/435TU/425S9U/425S9TU 000000 to 160000: 000.000 to 160.000 mm	
	Writing of processing element setting (straight)	1 to 8 (PLC1 to 8)	n	Station number: 0 (fixed)		17
			n+1	Command: B1H		
			n+2	Processing condition number: 0 to 7		
			n+3	Processing element number: 0 to 31		
			n+4	Element type 0: Straight		
			n+5 to n+6	Start point X coordinate	LP-430U/430TU/420S9U/420S9TU/410U/410TU -55000 to +55000: -055.000 to +055.000 mm LP-431U/431TU/421S9U/421S9TU/411U/411TU	
			n+7 to n+8	Start point Y coordinate	-27500 to +27500: -027.500 to +027.500 mm LP-435U/435TU/425S9U/425S9TU -80000 to +80000: -080.000 to +080.000 mm	
			n+9 to n+10	End point X coordinate	LP-430U/430TU/420S9U/420S9TU/410U/410TU -55000 to +55000: -055.000 to +055.000 mm LP-431U/431TU/421S9U/421S9TU/411U/411TU	
			n+11 to n+12	End point Y coordinate	-27500 to +27500: -027.500 to +027.500 mm LP-435U/435TU/425S9U/425S9TU -80000 to +80000: -080.000 to +080.000 mm	
			n+13 to n+14	Dashed line: dash length	LP-430U/430TU/420S9U/420S9TU/410U/410TU 000010 to 110000: 000.010 to 110.000 mm LP-431U/431TU/421S9U/421S9TU/411U/411TU 000010 to 550000: 000.010 to 055.000 mm LP-435U/435TU/425S9U/425S9TU 000010 to 160000: 000.010 to 160.000 mm	
			n+15 to n+16	Dashed line: space length	LP-430U/430TU/420S9U/420S9TU/410U/410TU 000000 to 110000: 000.000 to 110.000 mm LP-431U/431TU/421S9U/421S9TU/411U/411TU 000000 to 550000: 000.000 to 055.000 mm LP-435U/435TU/425S9U/425S9TU 000000 to 160000: 000.000 to 160.000 mm	

Contents		F0	F1 (= \$u n)		F2	
Processing element setting	Writing of processing element setting (circle)	1 to 8 (PLC1 to 8)	n	Station number: 0 (fixed)		15
			n+1	Command: B1H		
			n+2	Processing condition number: 0 to 7		
			n+3	Processing element number: 0 to 31		
			n+4	Element type 1: Circle		
			n+5 to n+6	Center X coordinate	LP-430U/430TU/420S9U/420S9TU/410U/410TU -55000 to +55000: -055.000 to +055.000 mm LP-431U/431TU/421S9U/421S9TU/411U/411TU	
			n+7 to n+8	Center Y coordinate	-27500 to +27500: -027.500 to +027.500 mm LP-435U/435TU/425S9U/425S9TU -80000 to +80000: -080.000 to +080.000 mm	
			n+9 to n+10	Radius	LP-430U/430TU/420S9U/420S9TU/410U/410TU 000010 to 110000: 000.010 to 110.000 mm LP-431U/431TU/421S9U/421S9TU/411U/411TU	
	n+11 to n+12	Dashed line: dash length	000010 to 550000: 000.010 to 055.000 mm LP-435U/435TU/425S9U/425S9TU 000010 to 160000: 000.010 to 160.000 mm			
	n+13 to n+14	Dashed line: space length	LP-430U/430TU/420S9U/420S9TU/410U/410TU 000000 to 110000: 000.000 to 110.000 mm LP-431U/431TU/421S9U/421S9TU/411U/411TU 000000 to 550000: 000.000 to 055.000 mm LP-435U/435TU/425S9U/425S9TU 000000 to 160000: 000.000 to 160.000 mm			
	Writing of processing element setting (arc)	1 to 8 (PLC1 to 8)	n	Station number: 0 (fixed)		21
			n+1	Command: B1H		
			n+2	Processing condition number: 0 to 7		
			n+3	Processing element number: 0 to 31		
			n+4	Element type 2: Arc		
			n+5 to n+6	Start point X coordinate	LP-430U/430TU/420S9U/420S9TU/410U/410TU -55000 to +55000: -055.000 to +055.000 mm LP-431U/431TU/421S9U/421S9TU/411U/411TU	
n+7 to n+8			Start point Y coordinate	-27500 to +27500: -027.500 to +027.500 mm LP-435U/435TU/425S9U/425S9TU -80000 to +80000: -080.000 to +080.000 mm		
n+9 to n+10			End point X coordinate	LP-430U/430TU/420S9U/420S9TU/410U/410TU -55000 to +55000: -055.000 to +055.000 mm LP-431U/431TU/421S9U/421S9TU/411U/411TU		
n+11 to n+12	End point Y coordinate	-27500 to +27500: -027.500 to +027.500 mm LP-435U/435TU/425S9U/425S9TU -80000 to +80000: -080.000 to +080.000 mm				
n+13 to n+14	Radius	000010 to 300000: 000.010 to 300.000 mm				
n+15	Drawing direction	0: Counterclockwise 1: Clockwise				
n+16	Center angle	0: Less than 180 deg 1: 180 deg or more				

Contents		F0	F1 (= \$u n)		F2
Processing element setting	Writing of processing element setting (arc)	1 to 8 (PLC1 to 8)	n+17 to n+18	Dashed line: dash length LP-430U/430TU/420S9U/420S9TU/410U/410TU 000010 to 110000: 000.010 to 110.000 mm LP-431U/431TU/421S9U/421S9TU/411U/411TU 000010 to 550000: 000.010 to 055.000 mm LP-435U/435TU/425S9U/425S9TU 000010 to 160000: 000.010 to 160.000 mm	21
			n+19 to n+20	Dashed line: space length LP-430U/430TU/420S9U/420S9TU/410U/410TU 000000 to 110000: 000.000 to 110.000 mm LP-431U/431TU/421S9U/421S9TU/411U/411TU 000000 to 550000: 000.000 to 055.000 mm LP-435U/435TU/425S9U/425S9TU 000000 to 160000: 000.000 to 160.000 mm	
Guide LD display		1 to 8 (PLC1 to 8)	n	Station number: 0 (fixed)	3
			n+1	Command: B2H	
			n+2	Display 0: Display stop 1: Center + print area 2: Print image 3: Dual pointer	
Week setting	Reading of week setting	1 to 8 (PLC1 to 8)	n	Station number: 0 (fixed)	2
			n+1	Command: 33H	
			n+2	Update day of the week 0: Sunday (updated at 0:00 midnight) 1: Monday (updated at 0:00 midnight)	
	Writing of week setting	1 to 8 (PLC1 to 8)	n	Station number: 0 (fixed)	4
			n+1	Command: B3H	
			n+2	Update day of the week 0: Sunday (updated at 0:00 midnight) 1: Monday (updated at 0:00 midnight)	
			n+3	The first week 0: The week including and after January 1 1: The week including the first Thursday of January	

Contents		F0	F1 (= \$u n)		F2
Barcode print data (1-/2-byte characters)	Reading of barcode print data (1-byte characters)	1 to 8 (PLC1 to 8)	n	Station number: 0 (fixed)	6
			n+1	Command: 35H	
			n+2	Printing character 0: 1-byte character	
			n+3	Setting section 0: Composite 1D section, except for composite 1: Composite 2D section	
			n+4	Barcode number: 0 to 7	
			n+5	Set row number (2-D code): 1 to 9	
			n+6 to n+20	Barcode data	
	Reading of barcode print data (2-byte characters)	1 to 8 (PLC1 to 8)	n	Station number: 0 (fixed)	6
			n+1	Command: 35H	
			n+2	Printing character 1: 2-byte character	
			n+3	Setting section 0: Composite 1D section, except for composite 1: Composite 2D section	
			n+4	Barcode number: 0 to 7	
			n+5	Set row number (2-D code): 1 to 9	
			n+6 to n+35	Barcode data	
	Writing of barcode print data (1-byte characters)	1 to 8 (PLC1 to 8)	n	Station number: 0 (fixed)	6 + barcode data word count (15 words maximum)
			n+1	Command: B5H	
			n+2	Printing character 0: 1-byte character	
			n+3	Setting section 0: Composite 1D section, except for composite components 1: Composite 2D section	
			n+4	Barcode number: 0 to 7	
			n+5	Set row number (2-D code): 1 to 9	
			n+6 to n+20	Barcode data	
	Writing of barcode print data (2-byte characters)	1 to 8 (PLC1 to 8)	n	Station number: 0 (fixed)	6 + barcode data word count (30 words maximum)
			n+1	Command: B5H	
			n+2	Printing character 1: 2-byte character	
n+3			Setting section 0: Composite 1D section, except for composite 1: Composite 2D section		
n+4			Barcode number: 0 to 7		
n+5			Set row number (2-D code): 1 to 9		
n+6 to n+35			Barcode data		

 Return data: Data stored from controller to V series

15.2.2 KW Series

Communication Setting

Editor

Communication setting

(Underlined setting: default)

Item	Setting	Remarks
Connection Mode	1 : 1 / <u>1:n</u> / Multi-link2 / Multi-link2 (Ethernet) / 1 : n Multi-link2 (Ethernet)	
Signal Level	RS-232C / <u>RS-422/485</u>	
Baud Rate	4800 / 9600 / <u>19200</u> / 38400 bps	
Data Length	7 / <u>8</u> bits	
Stop Bit	<u>1</u> / 2 bits	
Parity	None / <u>Odd</u> / Even	
Target Port No.	<u>1</u> to 99	
Header	<u>% (Header)</u> / < (Extension Header)	Model on which "< (Extension Header)" is available: KW1M-R

Eco-POWER METER

Communication parameters can be set by operating the keys on the Eco-POWER METER. For more information, refer to the manual for Eco-POWER METER.

KW1M/KW1M-H/KW8M

(Underlined setting: default)

Mode	Display	Item	Setting
MODE 3	PROT	Protocol setting mode	<u>MEWT: MEWTOCOL</u>
	NO.	Station number setting mode	<u>1</u> to 99
	SPD	Baud rate setting mode	4800: 4800 bps 9600: 9600 bps <u>19200: 19200 bps</u> 38400: 38400 bps
	FMT	Communication format setting mode	<u>8bit-o: data length 8 bits, odd parity</u> 7bit-n: data length 7 bits, without parity 7bit-E: data length 7 bits, even parity 7bit-o: data length 7 bits, odd parity 8bit-n: data length 8 bits, without parity 8bit-E: data length 8 bits, even parity

Stop bit: 1 (fixed)

KW1M-R(AKW1000/AKW1000K)

(Underlined setting: default)

Mode	Display	Item	Setting
MODE 3	PROT	Protocol setting mode	<u>MEWT: MEWTOCOL</u>
	SPD	Baud rate setting mode	4800: 4800 bps 9600: 9600 bps <u>19200: 19200 bps</u> 38400: 38400 bps
	FMT	Communication format setting mode	<u>8bit-o: data length 8 bits, odd parity</u> 7bit-n: data length 7 bits, without parity 7bit-E: data length 7 bits, even parity 7bit-o: data length 7 bits, odd parity 8bit-n: data length 8 bits, without parity 8bit-E: data length 8 bits, even parity
	PORT	Communication port setting mode	<u>232: RS-232C port</u> 485: RS-485 port

Stop bit: 1 (fixed)

AKW1000 and AKW1000K are not provided with the measuring function. Use each device along with a slave device AKW1131 or AKW1131K.

For establishing connection between master and slave devices, refer to the manual for Eco-POWER METER.

KW1M-R(AKW1131/AKW1131K)

(Underlined setting: default)

Mode	Display	Item	Setting
MODE 3	FORM	Wired/wireless setting mode	WIRED
	PROT	Protocol setting mode	<u>MEWT</u> : <u>MEWTOCOL</u>
	NO.	Station number setting mode	<u>1</u> to 99
	SPD	Baud rate setting mode	4800: 4800 bps 9600: 9600 bps <u>19200</u> : 19200 bps 38400: 38400 bps
	FMT	Communication format setting mode	<u>8bit-o</u> : data length 8 bits, odd parity 7bit-n: data length 7 bits, without parity 7bit-E: data length 7 bits, even parity 7bit-o: data length 7 bits, odd parity 8bit-n: data length 8 bits, without parity 8bit-E: data length 8 bits, even parity

Stop bit: 1 (fixed)

* Use system program version 2.2 or later.

KW2G/KW2G-H

(Underlined setting: default)

Mode	Display	Item	Setting
MODE 3	PROT	Protocol setting mode	<u>MEWT</u> : <u>MEWTOCOL</u>
	NO	Station number setting mode	<u>1</u> to 99
	SPD	Baud rate setting mode	4800: 4800 bps 9600: 9600 bps <u>19200</u> : 19200 bps 38400: 38400 bps
	FMT	Communication format setting mode	<u>8bit-o</u> : data length 8 bits, odd parity 7bit-n: data length 7 bits, without parity 7bit-E: data length 7 bits, even parity 7bit-o: data length 7 bits, odd parity 8bit-n: data length 8 bits, without parity 8bit-E: data length 8 bits, even parity
	STOP	Stop bit setting mode	<u>1</u> : 1 bit 2: 2 bits

KW4M

(Underlined setting: default)

Mode	Display	Item	Setting
MODE 3	NO.	Station setting mode	<u>1</u> to 99
	SPD	Baud rate setting mode	4800: 4800 bps 9600: 9600 bps <u>19200</u> : 19200 bps 38400: 38400 bps
	FMT	Communication format setting mode	<u>8bit-o</u> : data length 8 bits, odd parity 7bit-n: data length 7 bits, without parity 7bit-E: data length 7 bits, even parity 7bit-o: data length 7 bits, odd parity 8bit-n: data length 8 bits, without parity 8bit-E: data length 8 bits, even parity

Protocol: MEWTOCOL, stop bit: 1 (fixed)

Terminal station setting

Slide Switch	Item	Setting
	Terminal station setting	General: General station Terminal: Terminal station

KW7M

(Underlined setting: default)

Mode	Display	Item	Setting
MODE 2	PROT	Protocol setting mode	<u>MEWT</u> : <u>MEWTOCOL</u>
	NO.	Station number setting mode	<u>1</u> to 99
	SPD	Baud rate setting mode	4800: 4800 bps 9600: 9600 bps <u>19200</u> : <u>19200 bps</u> 38400: 38400 bps
	FMT	Communication format setting mode	<u>8bit-o</u> : data length 8 bits, odd parity 7bit-n: data length 7 bits, without parity 7bit-E: data length 7 bits, even parity 7bit-o: data length 7 bits, odd parity 8bit-n: data length 8 bits, without parity 8bit-E: data length 8 bits, even parity

Stop bit: 1 (fixed)

Available Device Memory

The available setting range of device memory varies depending on the model. Be sure to set within the range available for the model to be used. Use [TYPE] when assigning indirect device memory for macro programs.

Device Memory	TYPE	Remarks
DT (data register)	00H	

PLC_CTL

Macro command "PLC_CTL F0 F1 F2"

Contents	F0	F1 (= \$u n)	F2	
Status read	1 to 8 (PLC1 to 8)	n	Station number: 1 to 99	2
		n+1	Command: 0000H	
		n+2	Model code 1	
		n+3	Model code 2	
		n+4	Version	
		n+5	Operation mode 0: Stopped 1: Running	
		n+6	Error flag 0: Normal 1: Error	
		n+7	Self-diagnosis error number	

Return data: Data stored from Eco-POWER METER to V series

15.2.3 MINAS A4 Series

Communication Setting

Editor

Communication setting

(Underlined setting: default)

Item	Setting	Remarks
Connection Mode	1 : 1 / <u>1 : n</u> / Multi-link2 / Multi-link2 (Ethernet) / 1 : n Multi-link2 (Ethernet)	
Signal Level	<u>RS-232C</u> / RS-422/485	
Baud Rate	4800 / <u>9600</u> / 19200 / 38400 / 57600 bps	
Data Length	<u>8 bits</u>	
Stop Bit	<u>1 bit</u>	
Parity	<u>None</u>	
Target Port No.	0 to 15	

Servo Amplifier

Communication parameters can be set by operating the rotary switch and the keys on the front panel. For more information, refer to the servo amplifier manual.
Setting changes will take effect after turning the power off and back on. If changes are made to any settings, turn the power off and on again.

Rotary switch (ID)

ID	Item	Setting
	Axis number setting	RS-232C connection: 0 to F RS-485 connection: 1 to F

Parameters

(Underlined setting: default)

Mode	Item	Setting
0C	RS-232C communication baud rate setting	1: 4800 bps <u>2: 9600 bps</u> 3: 19200 bps 4: 38400 bps 5: 57600 bps
0D	RS-485 communication baud rate setting	1: 4800 bps <u>2: 9600 bps</u> 3: 19200 bps 4: 38400 bps 5: 57600 bps

Data length: 8, stop bit: 1, parity: none (fixed)

Available Device Memory

The available setting range of device memory varies depending on the model. Be sure to set within the range available for the model to be used. Use [TYPE] when assigning indirect device memory for macro programs.

Device Memory	TYPE	Remarks
STS (status)	00H	Read only
OPLSC (command pulse counter)	01H	Double-word, read only
FPLSC (feedback pulse counter)	02H	Double-word, read only
SPD (current speed)	03H	Read only
TLQ (current torque command)	04H	Read only
DEVIC (current deviation counter)	05H	Double-word, read only
INS (input signal)	06H	Double-word, read only
OUTS (output signal)	07H	Double-word, read only
STDC (current speed/torque/counter)	08H	Double-word, read only
SIO (status, input signal, output signal)	09H	Double-word, read only
FBS (feedback scale)	0AH	Read only
ABS (absolute encoder)	0BH	Double-word, read only
FSPLS (feedback scale deviation/total pulses)	0CH	Double-word, read only
IPM (parameter (individual))	0DH	* 1
CALM (current alarm data)	0EH	Read only
IALM (alarm history (individual))	0FH	Read only
AALM (alarm history (all))	10H	Read only
IAPM (parameter/property (individual))	11H	Read only
PAPM (parameter/property (all))	12H	Read only, except for parameter values (current values) *1

*1 Parameter values will be changed temporarily. When saving parameter changes to EEPROM, use the macro command PLC_CTL. For more information on the command PLC_CTL, see page 15-68.

Indirect Device Memory Designation

	15	8 7	0
n+0	Models (11 to 18)		Device type
n+1	Address No.		
n+2	Expansion code *		Bit designation
n+3	00		Station number

* In the expansion code, set which word, higher or lower, is to be read when a double-word address is specified.

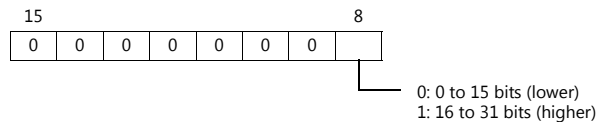

PLC_CTL

Macro command "PLC_CTL F0 F1 F2"

Contents	F0	F1 (= \$u n)		F2
Software version information readout	1 to 8 (PLC1 to 8)	n	Station number: 0 to 15	2
		n+1	Command: 0000H	
		n+2	Software version	
Amplifier model readout	1 to 8 (PLC1 to 8)	n	Station number: 0 to 15	2
		n+1	Command: 0001H	
		n+2	Model code 1st and 2nd characters	
		n+3	Model code 3rd and 4th characters	
		n+4	Model code 5th and 6th characters	
		n+5	Model code 7th and 8th characters	
		n+6	Model code 9th and 10th characters	
n+7	Model code 11th and 12th characters			
Motor model readout	1 to 8 (PLC1 to 8)	n	Station number: 0 to 15	2
		n+1	Command: 0002H	
		n+2	Model code 1st and 2nd characters	
		n+3	Model code 3rd and 4th characters	
		n+4	Model code 5th and 6th characters	
		n+5	Model code 7th and 8th characters	
		n+6	Model code 9th and 10th characters	
n+7	Model code 11th and 12th characters			
RS-232 protocol parameter setting	1 to 8 (PLC1 to 8)	n	Station number: 0 to 15	5
		n+1	Command: 0003H	
		n+2	Timeout period between characters 1 to 255 (unit: 0.1 sec.)	
		n+3	Protocol timeout period 1 to 255 (unit: 1 sec.)	
RS-485 protocol parameter setting	1 to 8 (PLC1 to 8)	n	Station number: 0 to 15	5
		n+1	Command: 0004H	
		n+2	Timeout period between characters 1 to 255 (unit: 0.1 sec.)	
		n+3	Protocol timeout period 1 to 255 (unit: 1 sec.)	
Execute privilege acquisition/release	1 to 8 (PLC1 to 8)	n	Station number: 0 to 15	3
		n+1	Command: 0005H	
		n+2	0: Request for execute privilege release 1: Request for execute privilege acquisition	
Parameter write to EEPROM	1 to 8 (PLC1 to 8)	n	Station number: 0 to 15	2
		n+1	Command: 0006H	
Alarm history clear	1 to 8 (PLC1 to 8)	n	Station number: 0 to 15	2
		n+1	Command: 0007H	
Alarm clear	1 to 8 (PLC1 to 8)	n	Station number: 0 to 15	2
		n+1	Command: 0008H	
Absolute clear	1 to 8 (PLC1 to 8)	n	Station number: 0 to 15	2
		n+1	Command: 0009H	

 Return data: Data stored from servo amplifier to V series

15.2.4 Wiring Diagrams

When Connected at CN1:

RS-232C

Wiring diagram 1 - C2

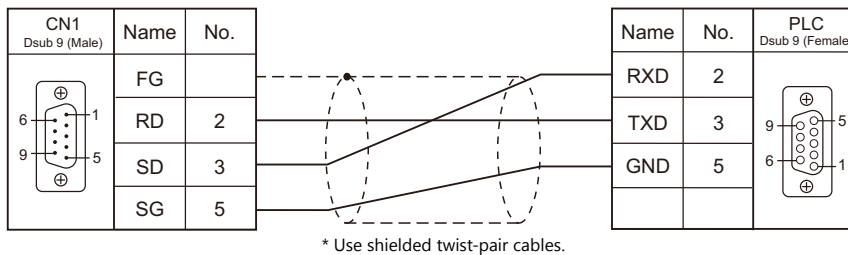

Wiring diagram 2 - C2

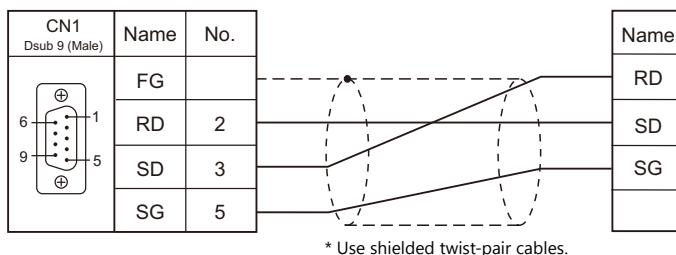

Wiring diagram 3 - C2

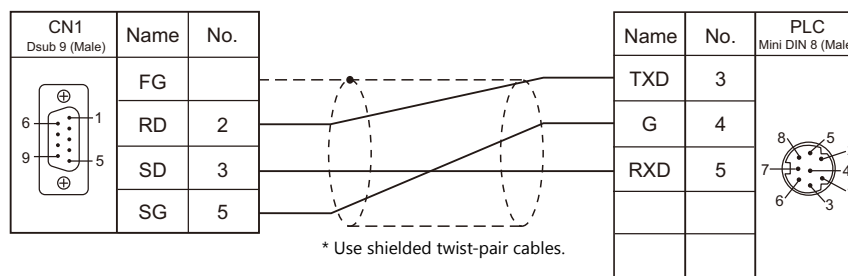

RS-485

Wiring diagram 1 - C4

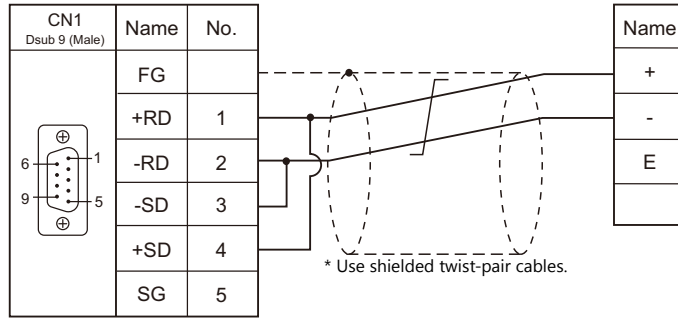

Eco-POWER METER connected at the terminal (except for KW4M)

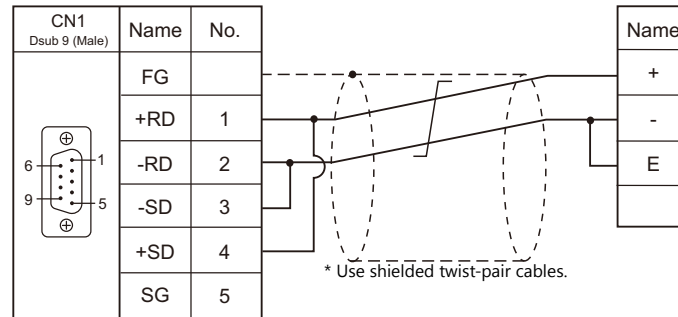

Wiring diagram 2 - C4

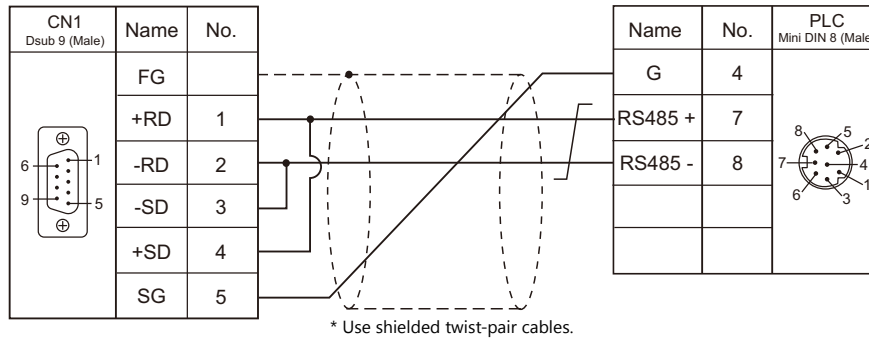

When Connected at MJ1/MJ2:

RS-232C

Wiring diagram 1 - M2

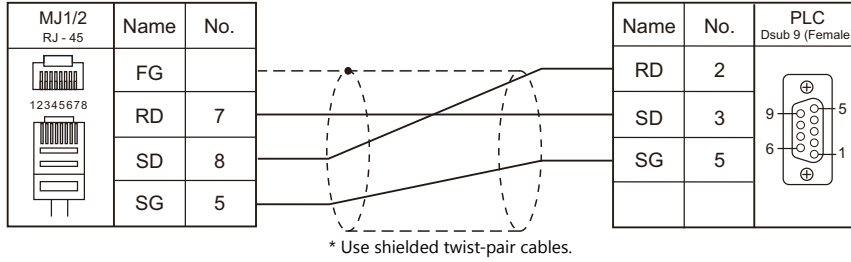

Wiring diagram 2 - M2

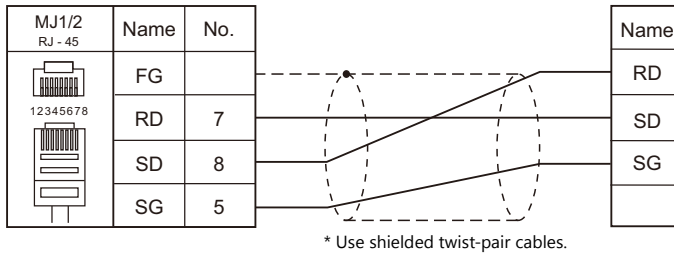

Wiring diagram 3 - M2

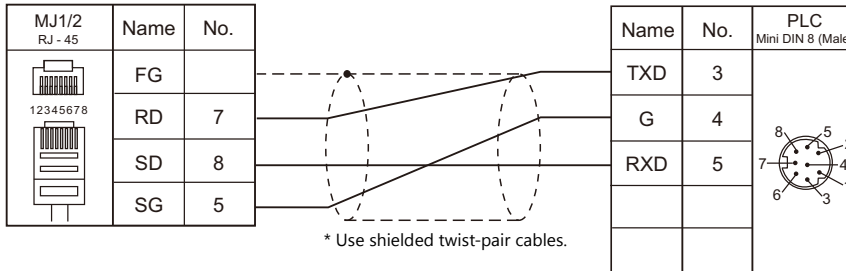

RS-485

Wiring diagram 1 - M4

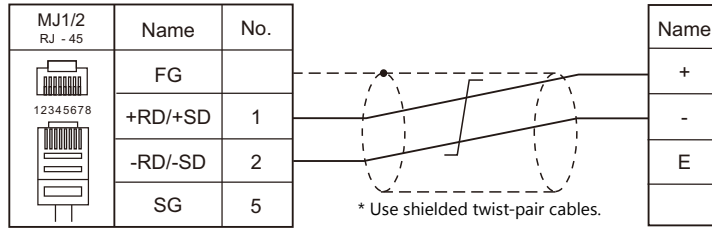

Eco-POWER METER connected at the terminal (except for KW4M)

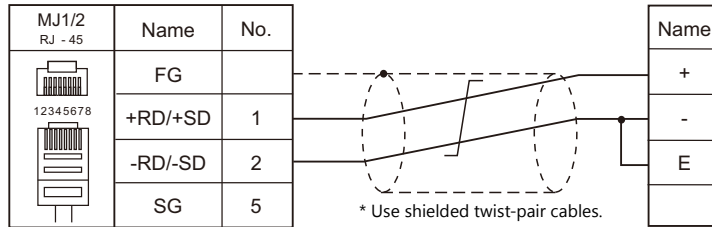

Wiring diagram 2 - M4

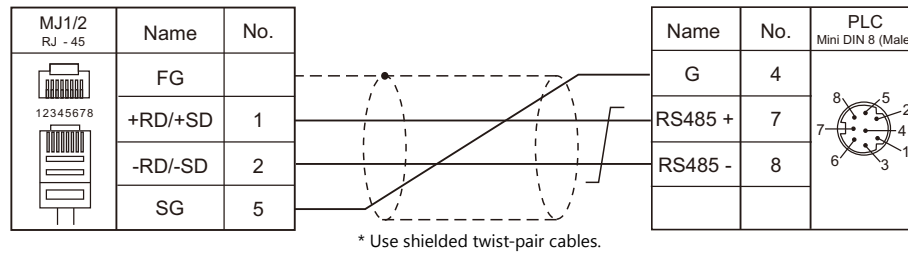

16. RKC

16.1 Temperature Controller/Servo/Inverter Connection

16.1 Temperature Controller/Servo/Inverter Connection

Serial Connection

Module-type Temperature Controller

PLC Selection on the Editor	Model	Port	Signal Level	Connection		Lst File
				CN1	MJ1/MJ2	
SR-Mini (MODBUS RTU)	H-PCP-A-x4N-4 * xx Z-1021	Modular connector 1/2	RS-422A	Wiring diagram 2 - C4	Wiring diagram 2 - M4	SR-Mini.Lst
	H-PCP-B-x4N-4 * xx Z-1021					
SR-Mini (Standard Protocol)	H-PCP-A-x4N-4 * xx	Modular connector 1/2	RS-422A	Wiring diagram 2 - C4	Wiring diagram 2 - M4	RKC_Std.Lst
	H-PCP-B-x4N-4 * xx					
SRV (MODBUS RTU)	V-TIO-A-xxxx-xx*xxx-xx-x-6	Communication terminal	RS-485 (2-wire system)	Wiring diagram 1 - C4	Wiring diagram 1 - M4	RKC_SRV.Lst
	V-TIO-C-xxxx-xx*xxx-xx-x-6					
SRZ (MODBUS RTU)	Z-TIO-A-x-xxx/x2-x xxx/Y ^{*1}	Communication terminal	RS-485 (2-wire system)	Wiring diagram 1 - C4	Wiring diagram 1 - M4	RKC_SRZ_TIO.Lst
	Z-TIO-B-x-xx/xN2-xxxx/Y ^{*1}					RKC_SRZ_DIO.Lst
	Z-DIO-A-x-xx/x-xxx2					

*1 Select a model on which Modbus communication is available.

*2: Modbus" for the communication protocol is selectable in the initial setting code when "specify quick start code 1 and 2" is selected as the quick start code.

Single Loop Temperature Controller

PLC Selection on the Editor	Model	Port	Signal Level	Connection		Lst File
				CN1	MJ1/MJ2	
CB100/CB400/ CB500/CB700/ CB900 (MODBUS RTU)	CB100xxx-xx*xx-5x/x Z-1021	Communication terminal	RS-485	Wiring diagram 1 - C4	Wiring diagram 1 - M4	CB100.Lst
	CB400xxx-xx*xx-5x/x Z-1021					
	CB500xxx-xx*xx-5x/x Z-1021					
	CB700xxx-xx*xx-5x/x Z-1021					
	CB900xxx-xx*xx-5x/x Z-1021					
REX-F400/F700/ F900 (Standard Protocol)	F400xxx-xx*xx-xxx-1x F700xxx-xx*xx-xxx-1x F900xxx-xx*xx-xxx-1x	Communication terminal	RS-232C	Wiring diagram 1 - C2	Wiring diagram 1 - M2	RKC_F400.Lst
	F400xxx-xx*xx-xxx-4x F700xxx-xx*xx-xxx-4x F900xxx-xx*xx-xxx-4x	Communication terminal	RS-422A	Wiring diagram 3 - C4	Wiring diagram 3 - M4	
	F400xxx-xx*xx-xxx-5x F700xxx-xx*xx-xxx-5x F900xxx-xx*xx-xxx-5x	Communication terminal	RS-485	Wiring diagram 1 - C4	Wiring diagram 1 - M4	
FB100/FB400/ FB900 (MODBUS RTU)	FB400-xx-x*xxx1/xx-xxxx FB400-xx-x*xxxW/xx-xxxx FB900-xx-x*xxx1/xx-xxxx FB900-xx-x*xxxW/xx-xxxx	Communication terminal	RS-232C	Wiring diagram 1 - C2	Wiring diagram 1 - M2	RKC_FB.Lst
	FB400-xx-x*xxx4/xx-xxxx FB900-xx-x*xxx4/xx-xxxx	Communication terminal	RS-422A	Wiring diagram 3 - C4	Wiring diagram 3 - M4	
	FB100-xx-x*E/xx-xxxx FB100-xx-x*F/xx-xxxx FB100-xx-x*G/xx-xxxx FB100-xx-x*H/xx-xxxx FB100-xx-x*I/xx-xxxx FB400-xx-x*xxx5/xx-xxxx FB400-xx-x*xxxW/xx-xxxx FB400-xx-x*xxxX/xx-xxxx FB400-xx-x*xxxY/xx-xxxx FB900-xx-x*xxx5/xx-xxxx FB900-xx-x*xxxW/xx-xxxx FB900-xx-x*xxxX/xx-xxxx FB900-xx-x*xxxY/xx-xxxx	Communication terminal	RS-485	Wiring diagram 1 - C4	Wiring diagram 1 - M4	

Multi-loop Temperature Controller

PLC Selection on the Editor	Model	Port	Signal Level	Connection		Lst File
				CN1	MJ1/MJ2	
MA900/MA901 (MODBUS RTU)	MA900-4xxxx-xx-x*xxx-x6/x	Communication terminal	RS-485	Wiring diagram 1 - C4	Wiring diagram 1 - M4	RKC_MA900.Lst
	MA901-8xxxx-xx-x*xxx-x6/x					RKC_MA901.Lst

16.1.1 CB100/CB400/CB500/CB700/CB900 (MODBUS RTU)

Communication Setting

Editor

Communication setting

(Underlined setting: default)

Item	Setting	Remarks
Connection Mode	1 : 1 / <u>1 : n</u> / Multi-link2 / Multi-link2 (Ethernet) / 1 : n Multi-link2 (Ethernet)	
Signal Level	<u>RS-422/485</u>	
Baud Rate	4800 / <u>9600</u> / 19200 bps	
Parity	<u>None</u> / Odd / Even	
Data Length	<u>8 bits</u>	
Stop Bit	<u>1 bit</u>	
Target Port No.	1 to 31	

CB100

Communication setting mode

When the [R/S] key is pressed while the [SET] key is held down in the PV/SV display mode, the controller enters in the "communication setting" mode.

(Underlined setting: default)

Indication	Item	Setting	Remarks
Add	Slave address	1 to 31	Communication is not performed when "0" is set.
bPS	Baud rate	1: 4800 bps 2: <u>9600 bps</u> 3: 19200 bps	
bIT	Data configuration	<u>0: 8 bits / 1 bit / none</u> 6: 8 bits / 1 bit / even 7: 8 bits / 1 bit / odd	
InT	Interval time setting	0 to 150	Interval time = set value × 1.666 ms

Available Device Memory

The available setting range of device memory varies depending on the controller model. Be sure to set within the range available for the controller to be used. Use [TYPE] when assigning indirect device memory for macro programs.

Device Memory	TYPE	Remarks
---	00H	

16.1.2 SRV (MODBUS RTU)

Communication Setting

Editor

Communication setting

(Underlined setting: default)

Item	Setting	Remarks
Connection Mode	1 : 1 / <u>1 : n</u> / Multi-link2 / Multi-link2 (Ethernet) / 1 : n Multi-link2 (Ethernet)	
Signal Level	RS-232C / <u>RS-422/485</u>	
Baud Rate	9600 / 19200 / <u>38400</u> bps	
Data Length	<u>8 bits</u>	
Stop Bit	<u>1 bit</u>	
Parity	<u>None</u> / Odd / Even	
Target Port No.	1 to 31	

SRV

Address setting switch

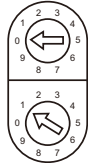
Switch	Setting	Remarks
	00 to 30	<p>Higher-order digit setting (× 10) Lower-order digit setting (× 1)</p> <p>The number that is one greater than the set value is the address.</p>

DIP switch setting

Switch	Setting	Contents	Remarks
1	ON	Baud rate: 38400 bps	ON, OFF: 9600 bps OFF, ON: 19200 bps
2	ON		
3	ON	Data bit configuration 8 bits / 1 bit / without parity	ON, OFF, ON: 8 bits / 1 bit / even ON, ON, ON: 8 bits / 1 bit / odd
4	OFF		
5	OFF		
6	ON	Protocol: Modbus	
7	OFF	-	
8	OFF	-	

* Communication time settings (send changeover time/data interval delay time) can be made using the switches 4, 5, and 6. For more information, refer to the communication instruction manual for SRV.

Available Device Memory

The available setting range of device memory varies depending on the controller model. Be sure to set within the range available for the controller to be used. Use [TYPE] when assigning indirect device memory for macro programs.

Device Memory	TYPE	Remarks
---	00H	

16.1.3 SR-Mini (MODBUS RTU)

Communication Setting

Editor

Communication setting

(Underlined setting: default)

Item	Setting	Remarks
Connection Mode	1 : 1 / <u>1:n</u> / Multi-link2 / Multi-link2 (Ethernet) / 1 : n Multi-link2 (Ethernet)	
Signal Level	RS-232C / <u>RS-422/485</u>	
Baud Rate	<u>9600</u> / 19200 bps	
Data Length	8 bits	
Stop Bit	1 bit	
Parity	<u>None</u> / Odd / Even	
Target Port No.	1 to 16	

SR-Mini

DIP switch

Switch	Setting	Contents	Remarks
1	ON	Modbus communication 8 bits / 1 bit / without parity	
2	ON		
3	ON	Baud rate: 9600 bps	OFF, ON: 4800 bps ON, ON: 19200 bps
4	OFF		

Slave address setting switch

Switch	Setting	Remarks
	<u>0</u> to F (= 1 to 16)	The number that is one greater than the set value is the address.

Available Device Memory

The available setting range of device memory varies depending on the controller model. Be sure to set within the range available for the controller to be used. Use [TYPE] when assigning indirect device memory for macro programs.

Device Memory	TYPE	Remarks
---	00H	

16.1.4 SR-Mini (Standard Protocol)

Communication Setting

Editor

Communication setting

(Underlined setting: default)

Item	Setting	Remarks
Connection Mode	1 : 1 / <u>1 : n</u> / Multi-link2 / Multi-link2 (Ethernet) / 1 : n Multi-link2 (Ethernet)	
Signal Level	RS-232C / <u>RS-422/485</u>	
Baud Rate	<u>9600</u> / 19200 bps	
Data Length	7 / <u>8</u> bits	
Stop Bit	<u>1</u> / 2 bits	
Parity	<u>None</u> / Odd / Even	
Target Port No.	0 to 15	

SR-Mini

DIP switch

Switch	Setting	Contents	Remarks
1	OFF	8 bits / 1 bit / without parity	OFF, ON: 7 bits, even parity ON, OFF: 7 bits, odd parity
2	OFF		
3	ON	Baud rate: 9600 bps	OFF, ON: 4800 bps ON, ON: 19200 bps
4	OFF		

Unit address setting switch

(Underlined setting: default)

Switch	Setting	Remarks
	<u>0</u> to F (= 0 to 15)	

Available Device Memory

The available setting range of device memory varies depending on the controller model. Be sure to set within the range available for the controller to be used. Use [TYPE] when assigning indirect device memory for macro programs.

Device Memory	TYPE	Remarks
GRP0 (normal: R)	00H	Read only
GRP1 (normal: RW)	01H	
GRP2 (initial: R)	02H	Read only
GRP3 (initial: RW)	03H	

* On the signal name reference list, every channel number is designated as "00".
Manually enter the value obtained by the following procedure: subtract "1" from the channel to access, and set the hexadecimal number of the obtained value.
The assigned device memory is expressed as shown on the right when editing the screen.

Example: GRP0000001 (measurement value for CH2 temperature)
└─ Channel number: -1 (HEX)
└─ Address

16.1.5 REX-F400/F700/F900 (Standard Protocol)

Communication Setting

Editor

Communication setting

(Underlined setting: default)

Item	Setting	Remarks
Connection Mode	1 : 1 / <u>1 : n</u> / Multi-link2 / Multi-link2 (Ethernet) / 1 : n Multi-link2 (Ethernet)	
Signal Level	RS-232C / <u>RS-422/485</u>	
Baud Rate	4800 / <u>9600</u> / 19200 bps	
Data Length	<u>7</u> / 8 bits	
Stop Bit	1 / <u>2</u> bits	
Parity	None / <u>Odd</u> / Even	
Target Port No.	0 to 31	

REX-F400/F700/F900

Parameter group (PG) 24

The communication parameters can be set using keys attached to the temperature controller. Be sure to match the settings to those made under [Communication Setting] of the editor.

(Underlined setting: default)

Indication	Item	Setting	Remarks
bIT	Communication data bit configuration	0: 8 bits / 1 bit / none 1: 8 bits / 2 bits / none 2: 8 bits / 1 bit / even 3: 8 bits / 2 bits / even 4: 8 bits / 1 bit / odd 5: 8 bits / 2 bits / odd 6: 7 bits / 1 bit / none 7: 7 bits / 2 bits / none 8: 7 bits / 1 bit / even 9: 7 bits / 2 bits / even 10: 7 bits / 1 bit / odd <u>11: 7 bits / 2 bits / odd</u>	
Add	Device address	<u>0</u> to 31	
bPS	Baud rate	2: 4800 bps <u>3: 9600 bps</u> 4: 19200 bps	
InT	Interval time setting	<u>0</u> to 250 msec	

* The "COMP" mode must be selected for communication with the V9 series.

Press the [MODE] key to display "Computer Mode Change", and change the mode from [LOC] to [COMP] by pressing the [V] key.

Available Device Memory

The available setting range of device memory varies depending on the controller model. Be sure to set within the range available for the controller to be used. Use [TYPE] when assigning indirect device memory for macro programs.

Device Memory	TYPE	Remarks
GRP0	00H	Read only
GRP1	01H	

16.1.6 MA900 / MA901 (MODBUS RTU)

Communication Setting

Editor

Communication setting

(Underlined setting: default)

Item	Setting	Remarks
Connection Mode	1 : 1 / <u>1 : n</u> / Multi-link2 / Multi-link2 (Ethernet) / 1 : n Multi-link2 (Ethernet)	
Signal Level	RS-232C / <u>RS-422/485</u>	
Baud Rate	4800 / <u>9600</u> / 19200 bps	
Data Length	<u>8 bits</u>	
Stop Bit	<u>1 bit</u>	
Parity	<u>None</u> / Odd / Even	
Target Port No.	1 to 31	

MA900/MA901

Setup setting mode

When the [R/S] key is pressed while the [SET] key is held down in the PV/SV monitor mode, the controller enters in the "setup setting" mode.

(Underlined setting: default)

Indication	Item	Setting	Remarks
Add	Slave address	1 to 31	Communication is not performed when "0" is set.
bPS	Baud rate	1: 4800 bps 2: <u>9600 bps</u> 3: 19200 bps	
bIT	Data configuration	0: 8 bits / 1 bit / <u>none</u> 2: 8 bits / 1 bit / even 4: 8 bits / 1 bit / odd	
InT	Interval time setting	0 to 250 msec	

Available Device Memory

The available setting range of device memory varies depending on the controller model. Be sure to set within the range available for the controller to be used. Use [TYPE] when assigning indirect device memory for macro programs.

Device Memory	TYPE	Remarks
---	00H	

16.1.7 SRZ (MODBUS RTU)

Communication Setting

Editor

Communication setting

(Underlined setting: default)

Item	Setting	Remarks
Connection Mode	1 : 1 / <u>1:n</u> / Multi-link2 / Multi-link2 (Ethernet) / 1 : n Multi-link2 (Ethernet)	
Signal Level	RS-232C / <u>RS-422/485</u>	
Baud Rate	4800 / 9600 / <u>19200</u> / 38400 bps	
Data Length	8 bits	
Stop Bit	1 bit	
Parity	<u>None</u> / Odd / Even	
Target Port No.	Z-TIO: 1 to 16 Z-DIO: 17 to 31	Default: 1

SRZ

DIP switch

Switch	Setting	Contents	Remarks
1	OFF	Baud rate: 19200 bps	OFF, OFF: 4800 bps ON, OFF: 9600 bps OFF, ON: 19200 bps ON, ON: 38400 bps
2	ON		
3	OFF	Data bit configuration 8 bits / without parity / 1 bit	OFF, ON, ON: 8 bits / even /1 bit ON, ON, ON: 8 bits / odd /1 bit
4	OFF		
5	ON		
6	ON	Protocol: Modbus	
7	OFF	-	
8	OFF	-	

Slave address setting switch

(Underlined setting: default)

Switch	Setting	Remarks
	<u>Q</u> to F	For Z-TIO, the number that is one greater than the set value is the address. (Range: 1 to 16) For Z-DIO, the number that is seventeen greater than the set value is the address. (Range: 17 to 32 [*])

* For connection to V9, the available address setting range is 0 to E (17 to 31).

Available Device Memory

The available setting range of device memory varies depending on the controller model. Be sure to set within the range available for the controller to be used. Use [TYPE] when assigning indirect device memory for macro programs.

Device Memory	TYPE	Remarks
---	00H	

16.1.8 FB100/FB400/FB900 (MODBUS RTU)

Communication Setting

Editor

Communication setting

(Underlined setting: default)

Item	Setting	Remarks
Connection Mode	1 : 1 / <u>1 : n</u> / Multi-link2 / Multi-link2 (Ethernet) / 1 : n multi-link2 (Ethernet)	
Signal Level	RS-232C / <u>RS-422/485</u>	
Baud Rate	4800 / 9600 / <u>19200</u> / 38400 bps	
Data Length	<u>8 bits</u>	
Stop Bit	<u>1</u> / 2 bits	
Parity	<u>None</u> / Odd / Even	
Target Port No.	1 to 31	

FB100/FB400/FB900

The communication parameters can be set using keys attached to the temperature controller. Be sure to match the settings to those made under [Communication Setting] of the editor.

Communication protocol (engineering mode F60)

Indication	Item	Setting	Remarks
CMP1	Communication 1 protocol	1: MODBUS	
CMP2	Communication 2 protocol	1: MODBUS	

* The temperature controller must be set to "STOP" (control stop) before making settings.

Communication parameter (setup setting mode)

(Underlined setting: default)

Port	Indication	Item	Setting	Remarks
Communication 1	Add1	Device address 1	1 to 31	Communication is not performed when "0" is set.
	bPS1	Baud rate 1	4.8: 4800 bps 9.6: 9600 bps <u>19.2: 19200 bps</u> 38.4: 38400 bps	
	bit1	Data bit configuration 1	<u>8n1: 8 bits / none / 1 bit</u> 8n2: 8 bits / none / 2 bits 8E1: 8 bits / even parity / 1 bit 8E2: 8 bits / even parity / 2 bits 8o1: 8 bits / odd parity / 1 bit 8o2: 8 bits / odd parity / 2 bits	
	InT1	Interval time 1	0 to 250 msec	
Communication 2	Add2	Device address 2	1 to 31	Communication is not performed when "0" is set.
	bPS2	Baud rate 2	4.8: 4800 bps 9.6: 9600 bps <u>19.2: 19200 bps</u> 38.4: 38400 bps	
	bit2	Data bit configuration 2	<u>8n1: 8 bits / none / 1 bit</u> 8n2: 8 bits / none / 2 bits 8E1: 8 bits / even parity / 1 bit 8E2: 8 bits / even parity / 2 bits 8o1: 8 bits / odd parity / 1 bit 8o2: 8 bits / odd parity / 2 bits	
	InT2	Interval time 2	0 to 250 msec	

Parameter changes will take effect when the temperature controller is turned off and on again or is switched from "STOP" to "RUN".

Available Device Memory

The available setting range of device memory varies depending on the controller model. Be sure to set within the range available for the controller to be used. Use [TYPE] when assigning indirect device memory for macro programs.

Device Memory	TYPE	Remarks
---	00H	0000 to 0017: Read only

16.1.9 Wiring Diagrams

When Connected at CN1:

RS-232C

Wiring diagram 1 - C2

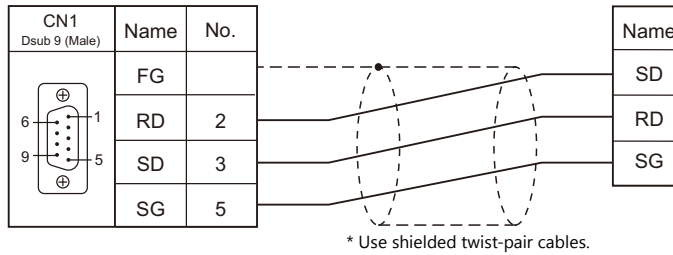

RS-422/RS-485

Wiring diagram 1 - C4

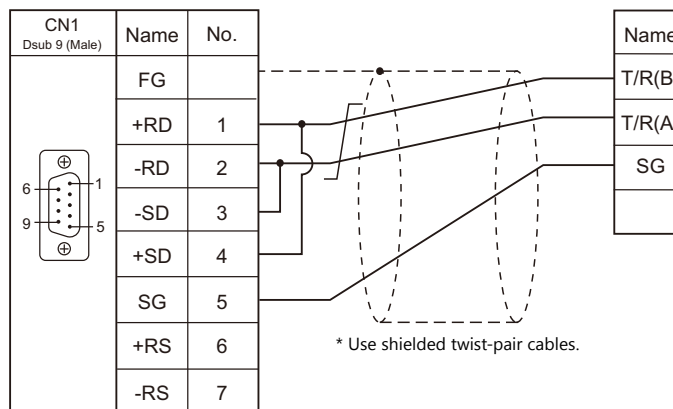

Wiring diagram 2 - C4

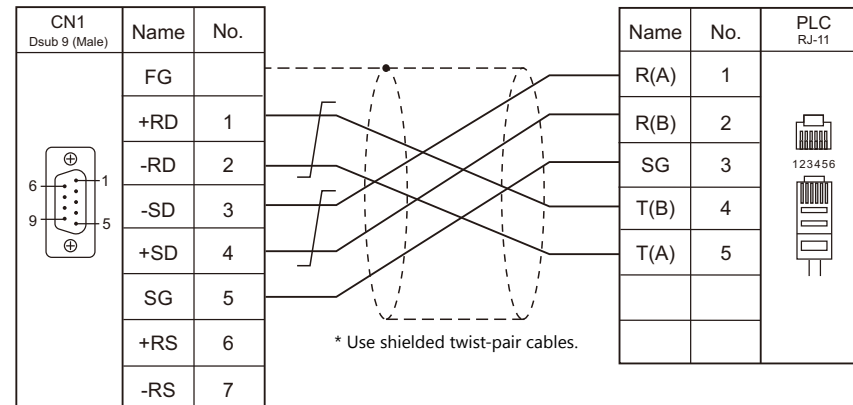

Wiring diagram 3 - C4

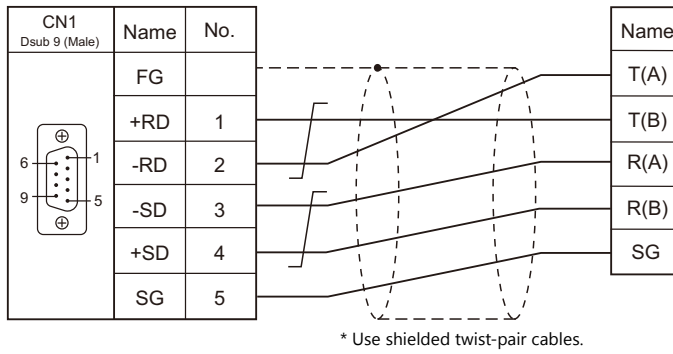

When Connected at MJ1/MJ2:

RS-232C

Wiring diagram 1 - M2

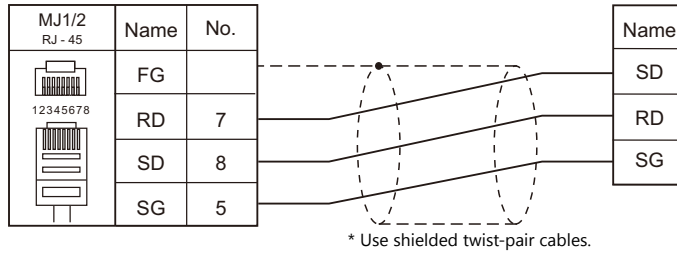

RS-422/RS-485

Wiring diagram 1 - M4

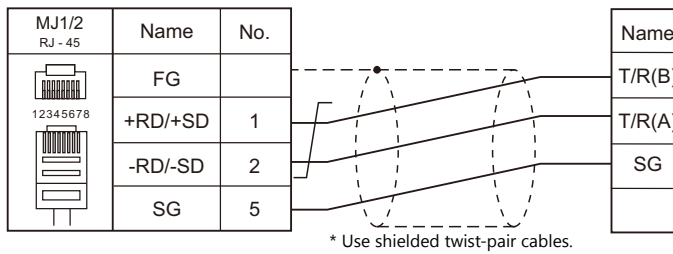

Wiring diagram 2 - M4

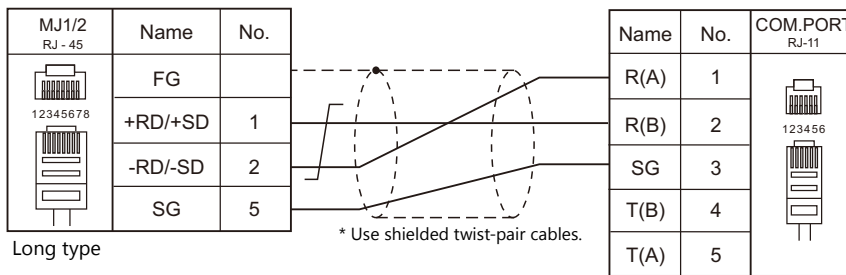

Long type

Short type

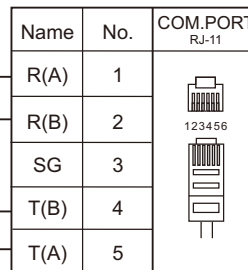

Use a long-type cable for connection between the MJ at the V9 and the controller, an RKC's cable between controllers, and short-type cable for the terminal controller.

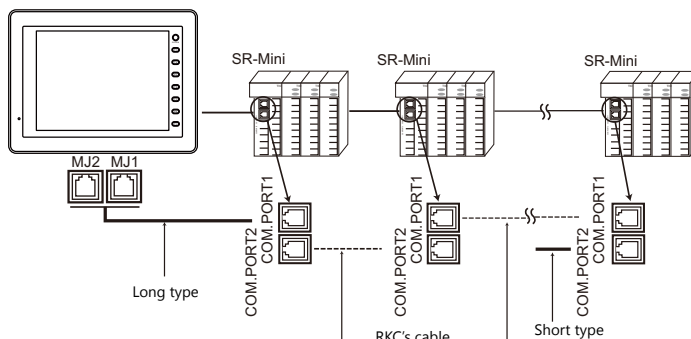

Wiring diagram 3 - M4

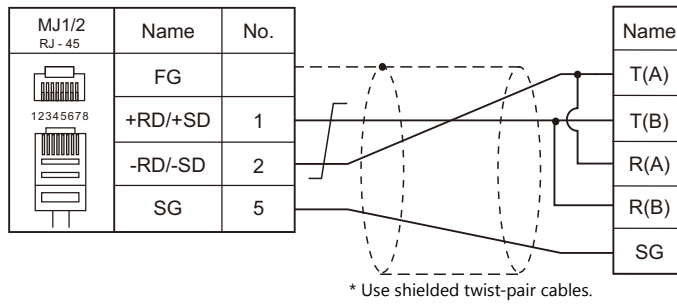

MEMO

Please use this page freely.

17. RS Automation

17.1 PLC Connection

17.1 PLC Connection

Serial Connection

PLC Selection on the Editor	CPU		Unit/Port	Signal Level	Connection		Ladder Transfer ^{*1}
					CN1	MJ1/MJ2	
NX7/NX Plus Series (70P/700P/CCU+)	NX70 plus	NX70-CPU70p1	COM port	RS-232C	Wiring diagram 1 - C2	Wiring diagram 1 - M2	×
			NX70-CCU+(CCU)				
	NX70 plus	NX70-CPU70p2	COM1/COM2	RS-485	Wiring diagram 1 - C4	Wiring diagram 1 - M4	
			NX70-CCU+(CCU)				
	NX70 plus	NX-CPU700p	COM1/COM2	RS-485	Wiring diagram 1 - C4	Wiring diagram 1 - M4	
			NX-CCU+(CCU)				
	NX7	NX7-xxxDx NX7R-xxADx	COM1	RS-232C	Wiring diagram 2 - C2	Wiring diagram 2 - M2	
				RS-485	Wiring diagram 2 - C4	Wiring diagram 2 - M4	
			COM2	RS-232C	Wiring diagram 3 - C2	Wiring diagram 3 - M2	
				RS-485	Wiring diagram 3 - C4	Wiring diagram 3 - M4	
	NX7S-xxxDx	COM1	RS-232C	Wiring diagram 1 - C2	Wiring diagram 1 - M2		
			RS-485	Wiring diagram 3 - C4	Wiring diagram 3 - M4		
N7/NX Series (70/700/750/CCU)	N70	CPL9211A	COM port	RS-232C	Wiring diagram 4 - C2	Wiring diagram 4 - M2	×
			RS-422	Wiring diagram 4 - C4	×	○	
	N70α	CPL9210A	COM port	RS-232C	Wiring diagram 6 - C2	Wiring diagram 6 - M2	○
			CPL9462(CCUC)	RS-232C	Wiring diagram 5 - C2	Wiring diagram 5 - M2	×
	N700	CPL7210A CPL7211A	COM port	RS-232C	Wiring diagram 4 - C2	Wiring diagram 4 - M2	×
			RS-422	Wiring diagram 4 - C4	×	○	
	N700α	CPL6210A CPL6210B	TOOL port	RS-232C	Wiring diagram 5 - C2	Wiring diagram 5 - M2	○
			COM port	RS-232C	Wiring diagram 7 - C2	Wiring diagram 7 - M2	×
	N7000	CPL5221B CPL5231	COM port	RS-232C	Wiring diagram 4 - C2	Wiring diagram 4 - M2	×
			RS-422	Wiring diagram 4 - C4	×	○	
	N7000α	CPL4210 CPL4211	CPL5462(CCUC)	RS-232C	Wiring diagram 5 - C2	Wiring diagram 5 - M2	×
			COM1	RS-422	Wiring diagram 4 - C4	×	○
	N7000α	CPL4210 CPL4211	COM2	RS-232C	Wiring diagram 7 - C2	Wiring diagram 7 - M2	×
			CPL5462(CCUC)	RS-232C	Wiring diagram 5 - C2	Wiring diagram 5 - M2	×
	NX70	NX70-CPU70	TOOL port	RS-232C	Wiring diagram 1 - C2	Wiring diagram 1 - M2	○
			NX70-CCU(CCUC)	RS-232C	Wiring diagram 8 - C2	Wiring diagram 8 - M2	×
		NX70-CPU750	TOOL port	RS-232C	Wiring diagram 1 - C2	Wiring diagram 1 - M2	○
			COM port	RS-232C	Wiring diagram 8 - C2	Wiring diagram 8 - M2	×
	NX700	NX-CPU750A NX-CPU750B NX-CPU750C NX-CPU750D	TOOL port	RS-232C	Wiring diagram 1 - C2	Wiring diagram 1 - M2	○
			COM port	RS-232C	Wiring diagram 8 - C2	Wiring diagram 8 - M2	×
NX-CCU(CCUC)			RS-232C	Wiring diagram 8 - C2	Wiring diagram 8 - M2	×	
TOOL port			RS-232C	Wiring diagram 1 - C2	Wiring diagram 1 - M2	○	
NX-CPU700		COM port	RS-232C	Wiring diagram 8 - C2	Wiring diagram 8 - M2	×	
		NX-CCU(CCUC)	RS-232C	Wiring diagram 8 - C2	Wiring diagram 8 - M2	×	
		TOOL port	RS-232C	Wiring diagram 1 - C2	Wiring diagram 1 - M2	○	
		NX-CCU(CCUC)	RS-232C	Wiring diagram 8 - C2	Wiring diagram 8 - M2	×	
X8 Series	X8-M16DDR X8-M14DDT X8-M32DDT	COM0/COM1	RS-232C	Wiring diagram 9 - C2	Wiring diagram 9 - M2	×	
			RS-485	Wiring diagram 5 - C4	Wiring diagram 4 - M4		

*1 For the ladder transfer function, see the V9 Series Reference Manual.

Ethernet Connection

PLC Selection on the Editor	CPU	Unit	TCP/IP	UDP/IP	Port No.	Keep Alive ^{*1}	Ladder Transfer ^{*2}
NX700 Series (Ethernet)	NX-CPU750A NX-CPU750B NX-CPU750C NX-CPU750D	NX-Ethernet	○	○	As desired ^{*3}	○	×
X8 Series (Ethernet)	X8-M16DDR X8-M14DDT X8-M32DDT	CPU with built-in Ethernet	○	×	50000 (fixed) (Max. 16 units)		

*1 For KeepAlive functions, see "1.3.2 Ethernet Communication".

*2 For the ladder transfer function, see the V9 Series Reference Manual.

*3 Eight connection settings are provided on the PLC; each for one V9 unit. Therefore, a maximum of eight V9 units can be connected to an Ethernet unit.

17.1.1 NX7/NX Plus Series (70P/700P/CCU+)

Communication Setting

Editor

Communication setting

(Underlined setting: default)

Item	Setting	Remarks
Connection Mode	<u>1:1</u> / 1 : n / Multi-link / Multi-link2 / Multi-link2 (Ethernet) / 1 : n Multi-link2 (Ethernet)	
Signal Level	<u>RS-232C</u> / RS-422/485	For RS-485 connection, set the transmission delay time to 3 msec or longer.
Baud Rate	4800 / <u>9600</u> / 19200 / 38400 / 57600 / 115K bps	57600 bps and 115K bps supported by NX7R only
Data Length	8 bits	
Stop Bit	1 bit	
Parity	None	
Target Port No.	<u>0</u> to 223, 255	

PLC

Be sure to match the settings to those made under [Communication Setting] of the editor.

System Information

Set a station number for the PLC using the PLC software "WINGPC". For more information, refer to the PLC manual issued by the manufacturer.

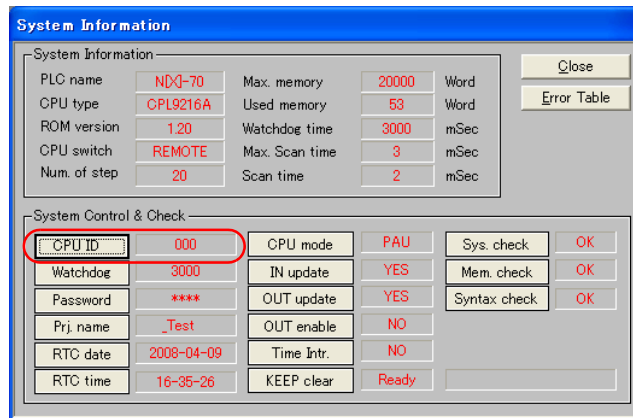

Setting Item	Setting	Remarks
CPU ID	0 to 223, 255	

NX70-CPU70p1 (COM Port)**DIP switches**

DIPSW	Contents		Setting		
	SW1	Terminating resistance (for RS-485 connection)	SW1	SW2	Terminating Resistance
	SW2		OFF	OFF	Invalid
			ON	ON	Valid
	SW3	Program write target	ON: EEPROM OFF: RAM		
	SW4	RS-232C / RS-485 selection	ON: RS-485 OFF: RS-232C		
	SW5	Baud rate selection	SW5	SW6	Baud rate
	OFF		OFF	9600bps	
	ON		OFF	38400bps	
	OFF		ON	19200bps	
SW6		ON	ON	4800bps	

NX70-CPU70p2 (COM Port) / NX-CPU700p (COM Port)**DIP switches 1**

DIPSW1	Contents		Setting		
	SW1	COM1 terminating resistance (for RS-485 connection)	SW1	SW2	Terminating Resistance
	SW2		OFF	OFF	Invalid
			ON	ON	Valid
	SW3	COM2 terminating resistance (for RS-485 connection)	SW3	SW4	Terminating Resistance
SW4	OFF		OFF	Invalid	
		ON	ON	Valid	

DIP switches 2

DIPSW2	Contents		Setting		
	SW1	Program write target	ON: EEPROM OFF: RAM		
	SW2	Not used	OFF		
	SW3	RS-232C / RS-485 selection (COM2)	ON: RS-485 OFF: RS-232C		
	SW4	RS-232C / RS-485 selection (COM1)	ON: RS-485 OFF: RS-232C		
	SW5	Baud rate selection (COM1)	SW5	SW6	Baud Rate
			OFF	OFF	9600bps
			ON	OFF	38400bps
			OFF	ON	19200bps
SW6		ON	ON	4800bps	
SW7	Baud rate selection (COM2)	SW7	SW8	Baud Rate	
		OFF	OFF	9600bps	
		ON	OFF	38400bps	
		OFF	ON	19200bps	
SW8		ON	ON	4800bps	

NX-CCU+(CCU) / NX70-CCU+(CCU)**DIP switches**

DIPSW	Contents		Setting			
	SW1	Baud rate selection	SW1	SW2	SW3	Baud Rate
	SW2		OFF	OFF	OFF	38400bps
	SW3		ON	OFF	OFF	19200bps
	SW4	Data length	OFF	ON	OFF	9600bps
	SW5	Parity check	ON	ON	OFF	4800bps
	SW6		ON: 8 bits			
	SW7	Stop bit	OFF: None			
	SW8	Reserved	OFF: 1 bit			
		OFF				

NX7-xxxDx/NX7R-xxADx/NX7S-xxxDx**DIP switches**

DIPSW	Contents		Setting
	SW1	RS-232C / RS-485 selection	ON: RS-485 OFF: RS-232C
	SW2	Terminating resistance (with RS-485 selected)	ON: Valid OFF: Invalid

Baud rate setting

The baud rate depends on the value specified for device memory SR509 or SR510.

COM	Baud Rate	Setting	Remarks
COM1= SR509 COM2= SR510	Auto setting:	0000 H	
	4800 bps	8003 H	
	9600 bps	8000 H	
	19200 bps	8001 H	
	38400 bps	8002 H	
	57600 bps	8004 H	Supported by NX7R only
	115K bps	8005 H	Supported by NX7R only

Available Device Memory

The available setting range of device memory varies depending on the PLC model. Be sure to set within the range available for the PLC to be used. Use [TYPE] when assigning indirect device memory for macro programs.

Device Memory	TYPE	Remarks
R (input/output)	00H	
L (link relay)	01H	
M (internal relay)	02H	
K (keep relay)	03H	
F (special relay)	04H	
W (word register)	05H	
TC (timer, counter)	06H	
SV (timer/set value)	07H	
PV (timer/current value)	08H	
SR (special register)	09H	
D (word register)	0AH	

17.1.2 N7/NX Series (70/700/750/CCU)

Communication Setting

Editor

Communication setting

(Underlined setting: default)

Item	Setting	Remarks
Connection Mode	<u>1:1</u> / 1 : n / Multi-link / Multi-link2 / Multi-link2 (Ethernet) / 1 : n Multi-link2 (Ethernet)	
Signal Level	<u>RS-232C</u> / RS-422/485	
Baud Rate	4800 / <u>9600</u> / 19200 / 38400 / 57600 / 76800 / 115K bps	
Data Length	7 / <u>8</u> bits	
Stop Bit	<u>1</u> / 2 bits	
Parity	None / <u>Odd</u> / Even	
Target Port No.	0 to 31	Only port No. 31 is valid, depending on the CPU model. For connection with a CCU module, select port No. 1.
Header	<u>% (Header)</u> / < (Extension Header)	Models on which "< (Expansion Header)" is available: NX-CPU750A / NX-CPU750B / NX-CPU750C / NX-CPU750D / NX70-CPU750
Monitor Registration	Unchecked / <u>Checked</u>	One V9 unit can be registered as a monitor for one PLC. When multi-link connection (n : 1) is selected, do not check this box for multiple V9 units.

PLC

Be sure to match the settings to those made under [Communication Setting] of the editor.

Available Device Memory

The available setting range of device memory varies depending on the PLC model. Be sure to set within the range available for the PLC to be used. Use [TYPE] when assigning indirect device memory for macro programs.

Device Memory	TYPE	Remarks
DT (data register)	00H	
X (external input)	01H	WX as word device, read only
Y (external output)	02H	WY as word device
R (internal relay)	03H	WR as word device
L (link relay)	04H	WL as word device
LD (link register)	05H	
FL (file register)	06H	
SV (timer, counter/set value)	07H	
EV (timer, counter/elapsed time)	08H	
T (timer/contact)	09H	Read only
C (counter/contact)	0AH	Read only

17.1.3 X8 Series

Communication Setting

Editor

Communication setting

(Underlined setting: default)

Item	Setting	Remarks
Connection Mode	<u>1</u> : 1 / 1 : n / Multi-link / Multi-link2 / Multi-link2 (Ethernet) / 1 : n Multi-link2 (Ethernet)	
Signal Level	<u>RS-232C</u> / RS-422/485	
Baud Rate	4800 / 9600 / 19200 / 38400 / 57600 / <u>115K</u> bps	
Data Length	<u>8</u> bits	
Stop Bit	<u>1</u> / 2 bits	
Parity	<u>None</u> / Even	
Target Port No.	0 to 249	

PLC

Make communication settings using the PLC software "XGPC" (version 1.0 or greater). For more information, refer to the PLC manual issued by the manufacturer.

Channel Configuration

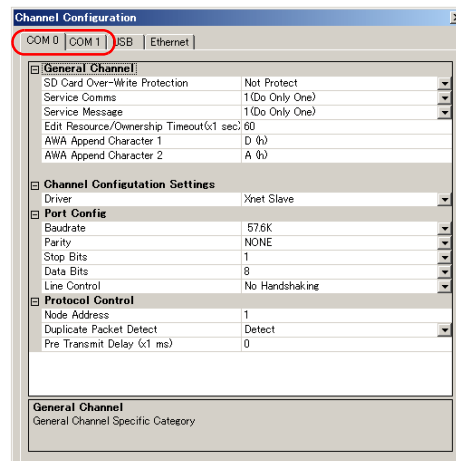

Setting Item	Setting	Remarks
Driver	Xnet Slave	
Baudrate	4.8K / 9.6K / 19.2K / 38.4K / 57.6K / 115.2K	
Parity	NONE / EVEN	
Stop bits	1 / 2	
Data bits	8	
Line Control	No Handshaking / No Handshaking (RS485 Network)	RS-232C connection: No Handshaking RS-485 connection: No Handshaking (RS485 Network)
Node Address	0 to 249	

Available Device Memory

The available setting range of device memory varies depending on the PLC model. Be sure to set within the range available for the PLC to be used. Use [TYPE] when assigning indirect device memory for macro programs.

Device Memory	TYPE	Remarks
N (Integer)	00H	
X (Input)	01H	
Y (Output)	02H	
SR (System Registers)	03H	
B (Binary)	04H	
F (Floating Point)	05H	Real number. Bit designation is not possible.
L (Long)	06H	Double-word
A (ASCII)	07H	
ST (String)	08H	STRING type
TM (Timer)	09H	
CT (Counter)	0AH	
CR (Control)	0BH	

Address denotations

The assigned device memory is expressed as shown below when editing the screen.

- Integer, System Registers, Binary, Floating Point, Long, or ASCII addresses

Word designation

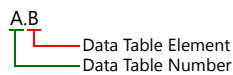

Bit designation

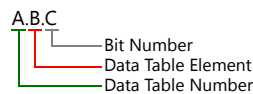

- Input, Output addresses

Word designation

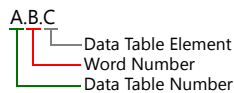

Bit designation

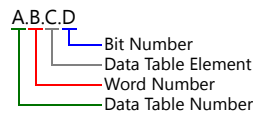

- String, Timer, Counter, or Control addresses

Word designation

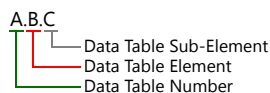

Bit designation

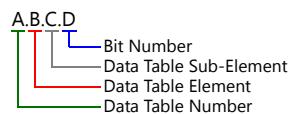

Mnemonics can be used to specify Timer, Counter, or Control addresses.

The following shows the representation using mnemonics:

On PLC	On V-SFT
TimeBase0	TB0
TimeBase1	TB1
Done	DN
TimerTiming	TT
Enable	EN
Underflow	UF
Overflow	OF
CountDown	CD
CountUp	CU
Found	FD
Inhibit	IH

On PLC	On V-SFT
Unload	UL
Error	ER
Empty	EM
EnableUnload	EU
Preset(Low)	PRE(L)
Preset(High)	PRE(H)
Accumulator(Low)	ACC(L)
Accumulator(High)	ACC(H)
Length	LEN
Position	POS

- Mnemonics can be used for bit designation on condition that Data Table Sub-Element = 0.
Example: TM9.0.0.8 → TM9.0.0.TB0
- Mnemonics can be used for device memory address designation on condition that Data Table Sub-Element = 1 to 4.
Example: TM9.0.1 → TM9.0.PRE(L)

For more information on using mnemonics, refer to the PLC manual issued by the manufacturer.

Indirect Device Memory Designation

	15	MSB	8	7	LSB	0
n+0	Model				Device type	
n+1	Lower address No.					
n+2	Higher address No.					
n+3	00		Bit designation			
n+4	00		Station number			

- Device memory other than String, Timer, Counter, and Control

Example: Indirect device memory designation of "N20.100"

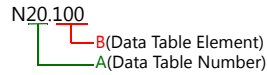

Converting A to binary
20(DEC) = 10100(BIN)

11	10	09	08	07	06	05	04	03	02	01	00
0	0	0	0	0	0	0	1	0	1	0	0

X is indicated under bits 04-07, Y is indicated under bits 01-02.

Converting B to binary
100(DEC) = 1100100(BIN)

11	10	09	08	07	06	05	04	03	02	01	00
0	0	0	0	0	1	1	0	0	1	0	0

Z is indicated under bits 05-07.

Arranging the values X, Y and Z in the following order

n + 1 (lower address number)

15	14	13	12	11	10	09	08	07	06	05	04	03	02	01	00
0	1	0	1	0	0	0	0	0	1	1	0	0	1	0	0

Y is indicated under bits 12-13, Z is indicated under bits 05-06.

n + 2 (higher address number)

15	14	13	12	11	10	09	08	07	06	05	04	03	02	01	00
0	0	0	0	0	0	0	0	0	0	0	0	0	0	0	1

0 fixed is indicated under bits 00-07, X is indicated under bit 00.

0000100100000010 (BIN) = 4064 (HEX): Lower address number
0000000000000001 (BIN) = 1 (HEX): Higher address number

- String, Timer, Counter, or Control device memory

Example: Indirect device memory designation of "ST3.25.10"

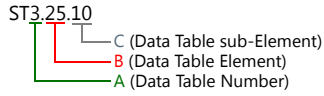

Converting A to binary
 3(DEC)= 11(BIN)

11	10	09	08	07	06	05	04	03	02	01	00
0	0	0	0	0	0	0	0	0	0	1	1

W

Converting B to binary
 25(DEC)= 11001(BIN)

11	10	09	08	07	06	05	04	03	02	01	00
0	0	0	0	0	0	0	1	1	0	0	1

X

Y

Converting C to binary
 10(DEC)= 1010(BIN)

05	04	03	02	01	00
0	0	1	0	1	0

Z

Arranging the values W, X, Y and Z in the following order

n + 1 (lower address number)

15	14	13	12	11	10	09	08	07	06	05	04	03	02	01	00
0	0	0	0	0	1	1	0	0	1	0	0	1	0	1	0

Y

Z

n + 2 (higher address number)

15	14	13	12	11	10	09	08	07	06	05	04	03	02	01	00
0	0	0	0	0	0	0	0	0	0	0	0	1	1	0	0

0 fixed

W

X

0000011001001010 (BIN) = 64A (HEX): Lower address number

0000000000001100 (BIN) = C (HEX): Higher address number

17.1.4 NX700 Series (Ethernet)

Communication Setting

Editor

Make the following settings on the editor. For more information, see "1.3.2 Ethernet Communication".

- IP address for the V9 unit
 - When specified on the screen program:
[System Setting] → [Hardware Setting] → [Local Port IP Address]
 - When specified on the V9 unit:
Local mode → [LAN Setting]
- Port number for the V9 unit (for communication with PLC)
[System Setting] → [Hardware Setting] → [PLC Properties] → [Communication Setting]
- Others
[System Setting] → [Hardware Setting] → [PLC Properties] → [Communication Setting]

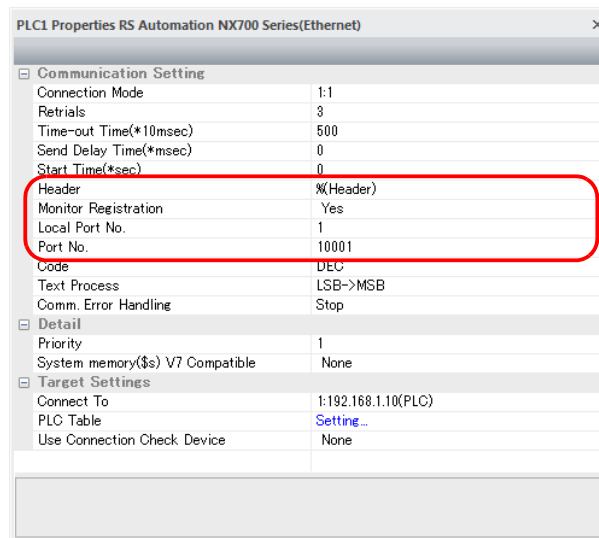

Item	Contents
Header	Select a format of communication with the PLC. % (Header) / < (Extension Header)
Monitor Registration	Select [Yes] in the case where a monitor registration command is used for communication with the PLC. * One V9 unit can be registered as a monitor for one PLC. Do not select [Yes] for multiple V9 units in n : 1 connection.
Local Port No.	Set the local port number of the V9 unit (1 to 31). Set the same number as the one set for "Target node MEWTOCOL station number" on the [Connection Setting] dialog of the PLC.

* For settings other than the above, see "1.4 Hardware Settings".

- IP address and port number of the PLC
 Register on the [PLC Table] in [System Setting] → [Hardware Setting] → [PLC Properties] → [Target Settings].
 Set the same PLC table number as the one set for "MEWTOCOL Station Number" ([Initial Information Setting] → [Local Node Setting]).

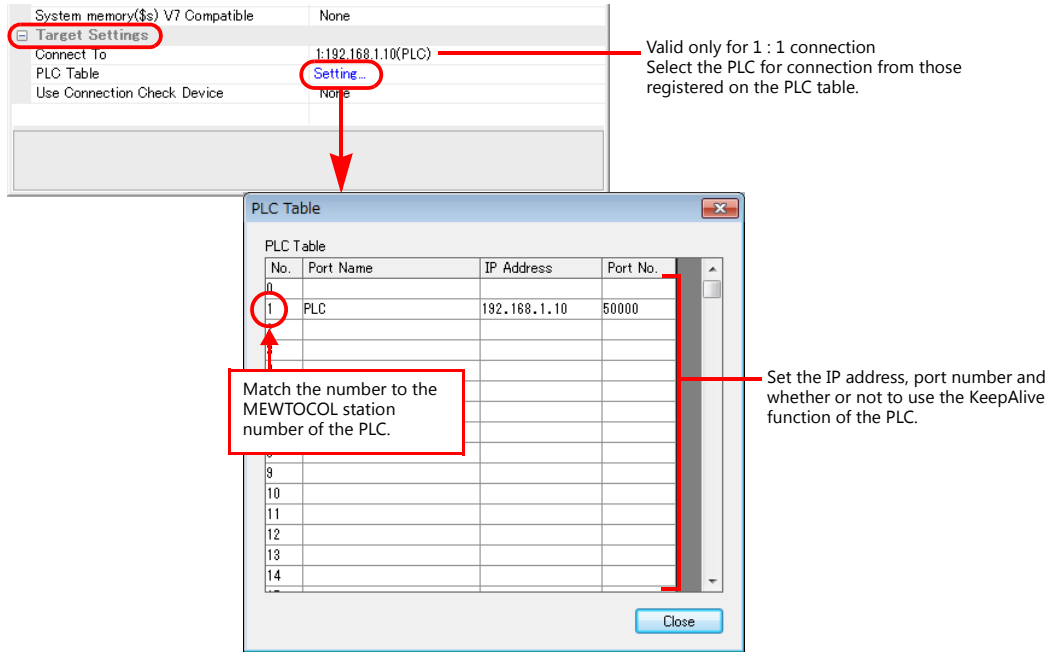

PLC

Make mode settings using the Ethernet unit "NX-Ethernet".

Mode setting switch

Switch	Setting	Contents	Remarks
2	ON	Auto connection function	

Make the PLC setting using the configuration tool "Configurator ET". For more information, refer to the PLC manual issued by the manufacturer.

Initial information setting

Item	Setting	
Local Node Setting	IP Address	Set the IP address of the PLC.
	MEWTOCOL Station Number	1 to 64 * The same number must be specified for the PLC table number of the V9.

Connection setting

Item	Setting	
Connection 1 to 8 * Select a port to which the V9 is connected.	Communication Mode	TCP/IP, UDP/IP
	Open Type	Unpassive
	Usage	MEWTOCOL communication
	Local Node (PLC) Port Number	As desired
	Target Node IP Address	IP address of the V9
	Target Node Port Number	Port number of the V9
	Target Node MEWTOCOL Station Number	1 to 64 * Match the number to the one set for [Local Port No.] under [Communication Setting] on the V9.
Connection Setting	Valid	

Available Device Memory

The available setting range of device memory varies depending on the PLC model. Be sure to set within the range available for the PLC to be used. Use [TYPE] when assigning indirect device memory for macro programs.

Device Memory	TYPE	Remarks
DT (data register)	00H	
X (external input)	01H	WX as word device, read only
Y (external output)	02H	WY as word device
R (internal relay)	03H	WR as word device
L (link relay)	04H	WL as word device
LD (link register)	05H	
FL (file register)	06H	
SV (timer, counter/set value)	07H	
EV (timer, counter/elapsed time)	08H	
T (timer/contact)	09H	Read only
C (counter/contact)	0AH	Read only

17.1.5 X8 Series (Ethernet)

Communication Setting

Editor

Make the following settings on the editor. For more information, see "1.3.2 Ethernet Communication".

- IP address for the V9 unit
 - When specified on the screen program:
[System Setting] → [Hardware Setting] → [Local Port IP Address]
 - When specified on the V9 unit:
Local mode → [LAN Setting]
- Port number for the V9 unit (for communication with PLC)
[System Setting] → [Hardware Setting] → [PLC Properties] → [Communication Setting]

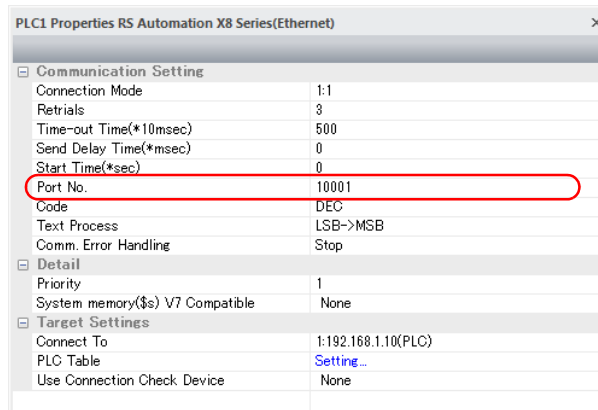

- IP address and port number (No. 50000) of the PLC
Register on the [PLC Table] in [System Setting] → [Hardware Setting] → [PLC Properties] → [Target Settings].

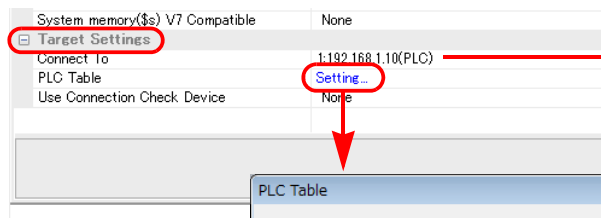

Valid only for 1 : 1 connection
Select the PLC for connection from those registered on the PLC table.

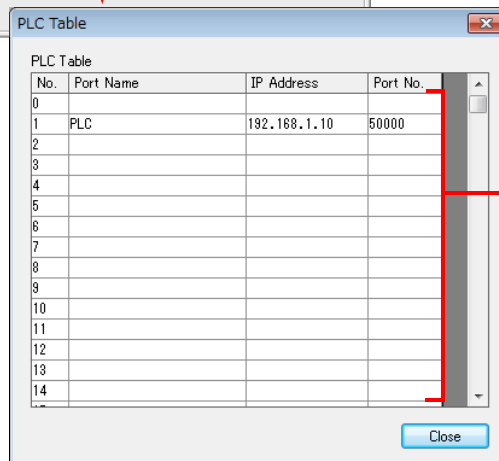

Set the IP address, port number and whether or not to use the KeepAlive function of the PLC.

PLC

Set a station number for the PLC using the PLC software “XGPC” (version 1.0 or greater). For more information, refer to the PLC manual issued by the manufacturer.

Channel Configuration

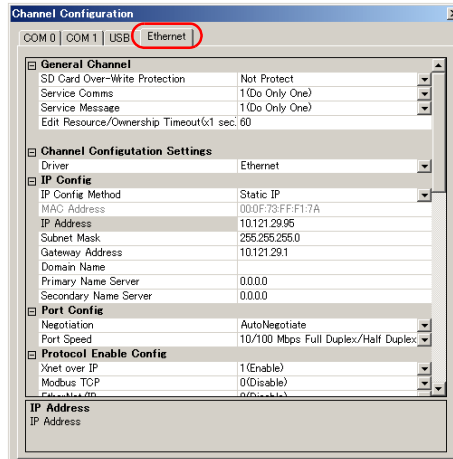

Setting Item	Setting	Remarks
IP Address	Set the IP address of the PLC.	
Subnet Mask	Set the subnet mask of the PLC.	
Gateway Address	Set according to the environment.	

Available Device Memory

The contents of “Available Device Memory” are the same as those described in “17.1.3 X8 Series”.

17.1.6 Wiring Diagrams

When Connected at CN1:

RS-232C

Wiring diagram 1 - C2

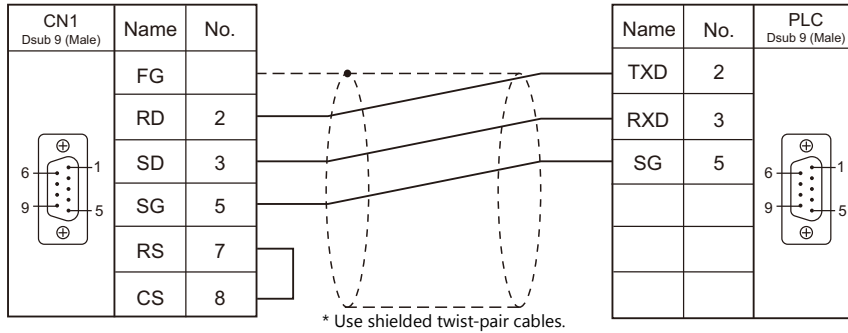

Wiring diagram 2 - C2

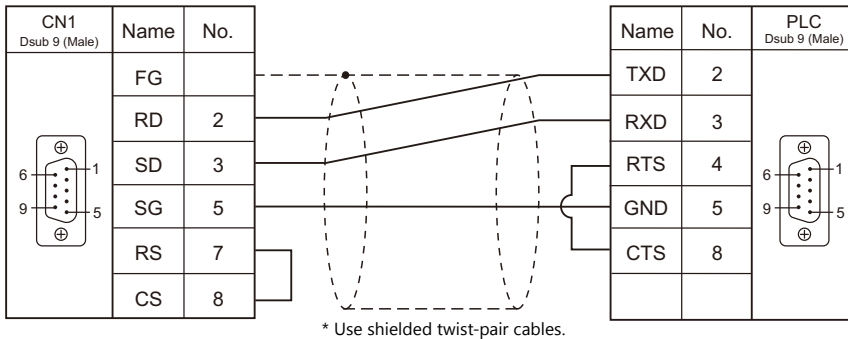

Wiring diagram 3 - C2

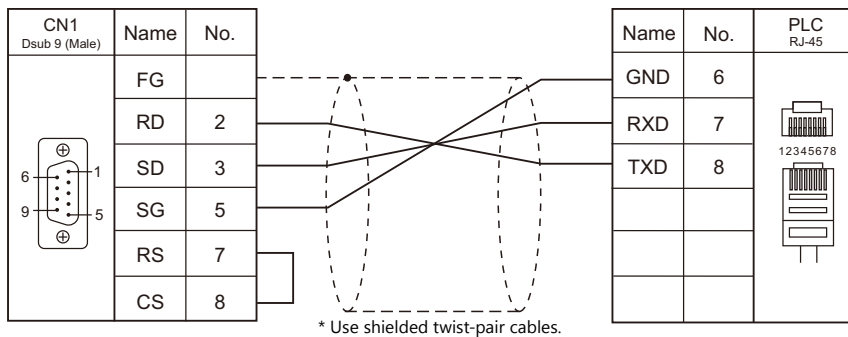

Wiring diagram 4 - C2

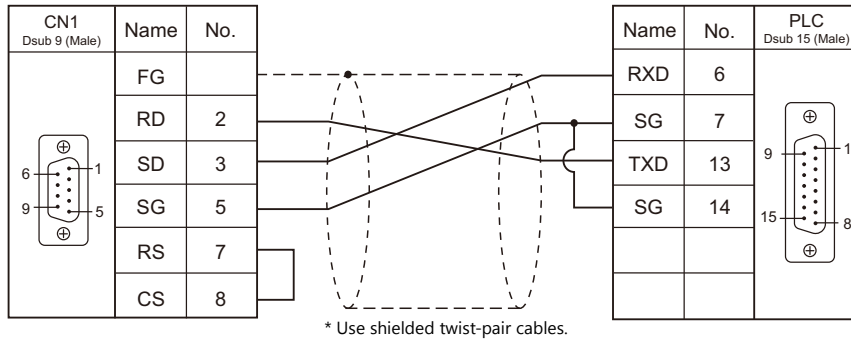

Wiring diagram 5 - C2

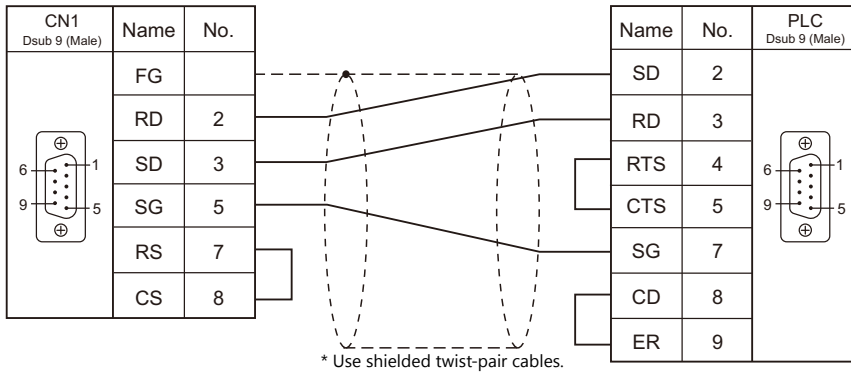

Wiring diagram 6 - C2

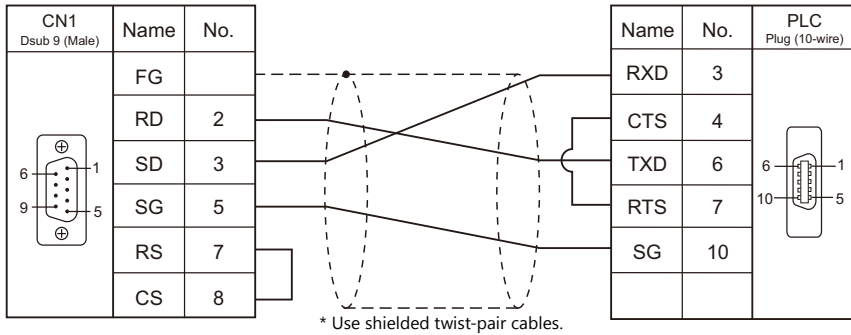

Wiring diagram 7 - C2

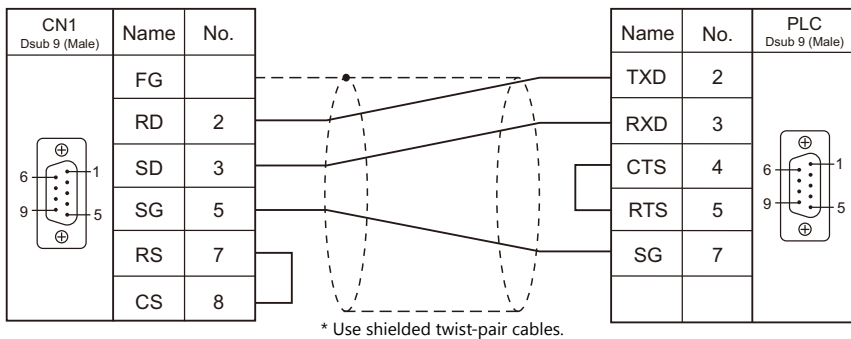

Wiring diagram 8 - C2

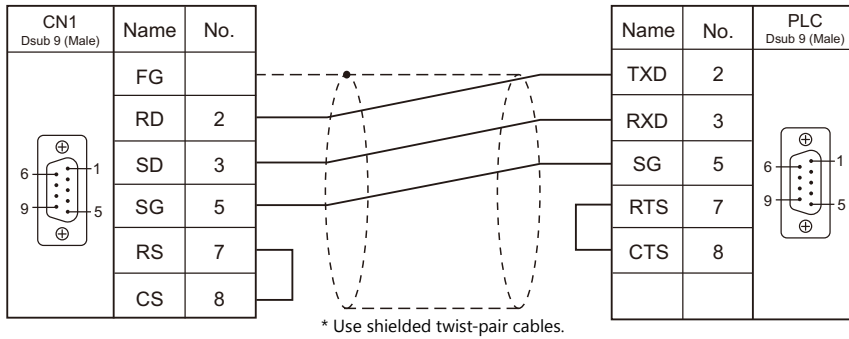

Wiring diagram 9 - C2

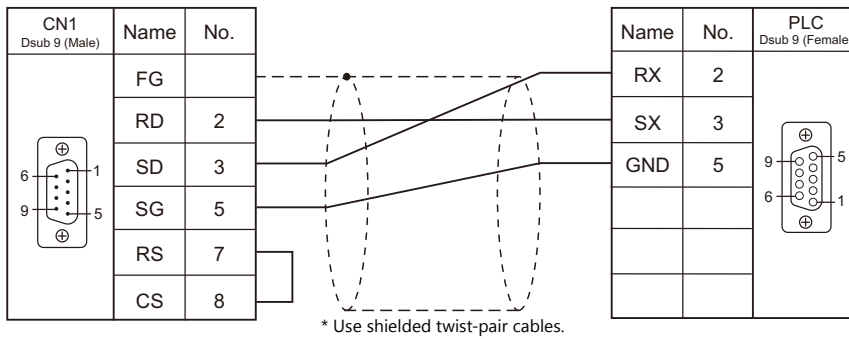

RS-422/RS-485

Wiring diagram 1 - C4

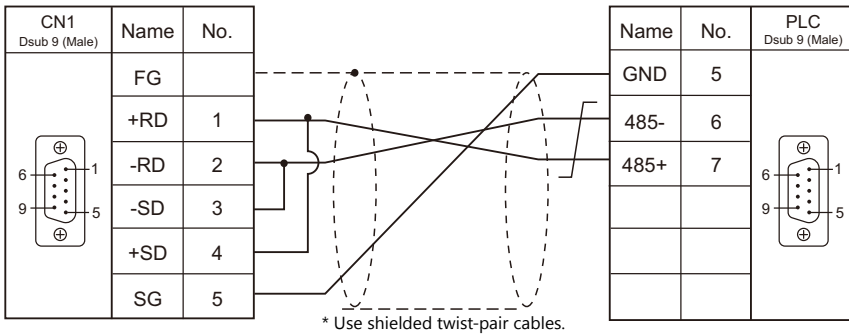

Wiring diagram 2 - C4

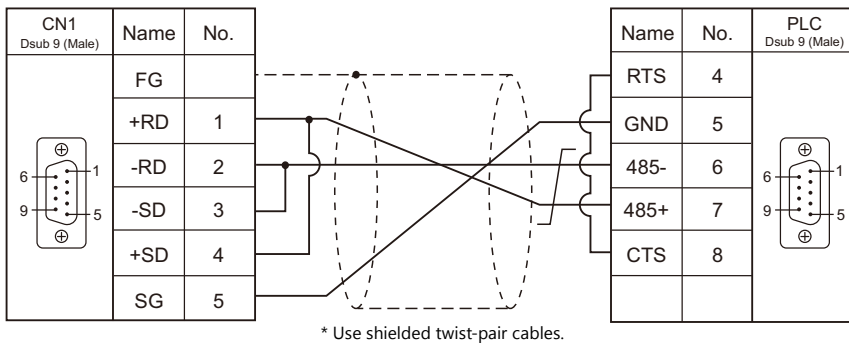

Wiring diagram 3 - C4

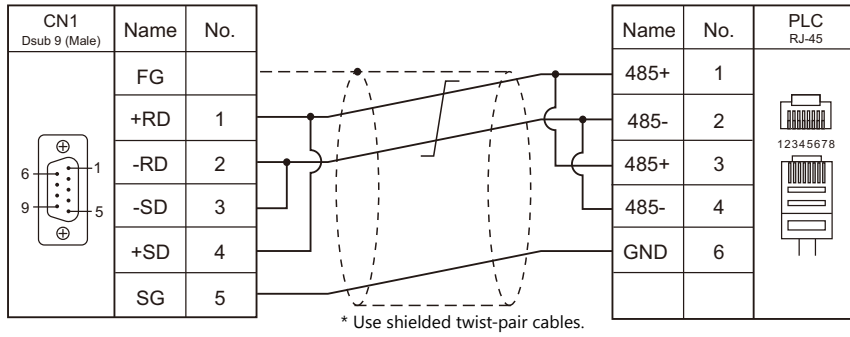

Wiring diagram 4 - C4

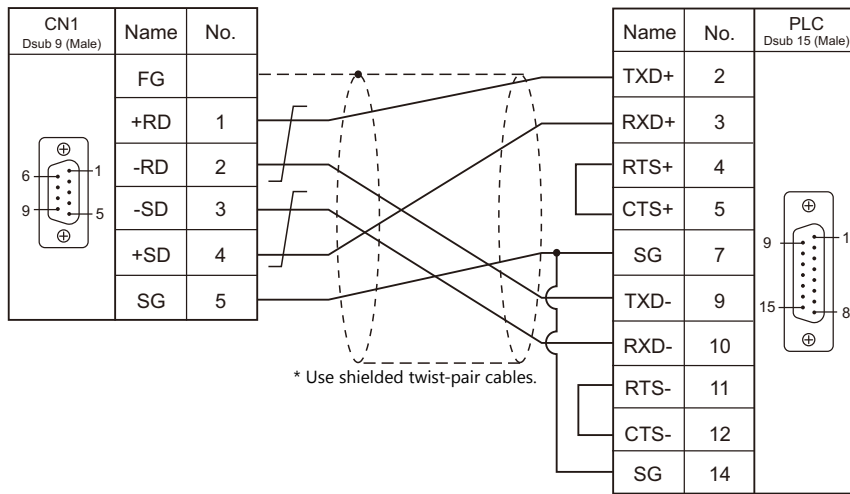

Wiring diagram 5 - C4

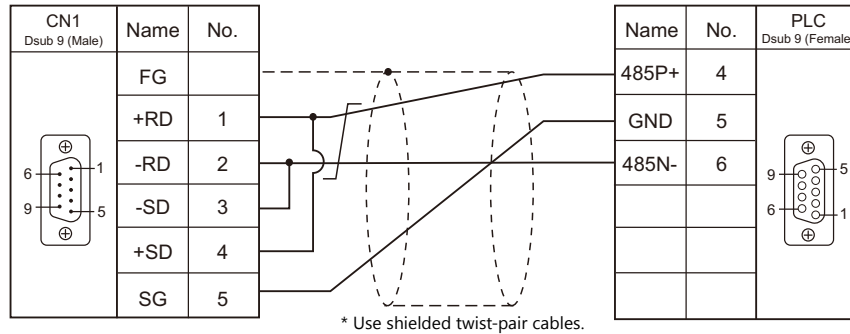

When Connected at MJ1/MJ2:

RS-232C

Wiring diagram 1 - M2

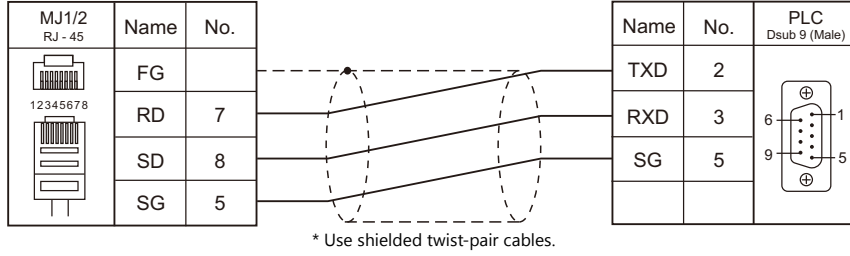

Wiring diagram 2 - M2

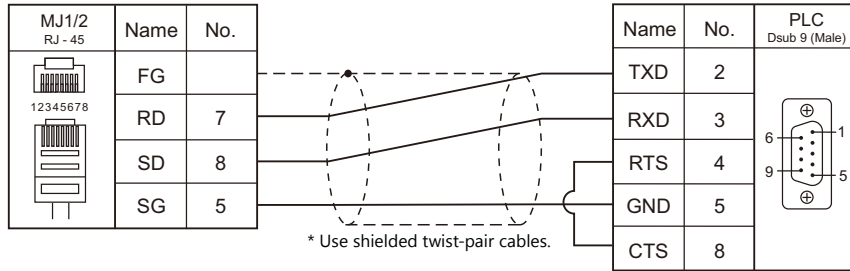

Wiring diagram 3 - M2

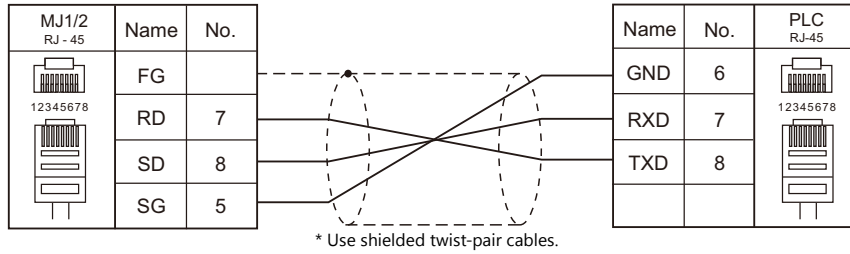

Wiring diagram 4 - M2

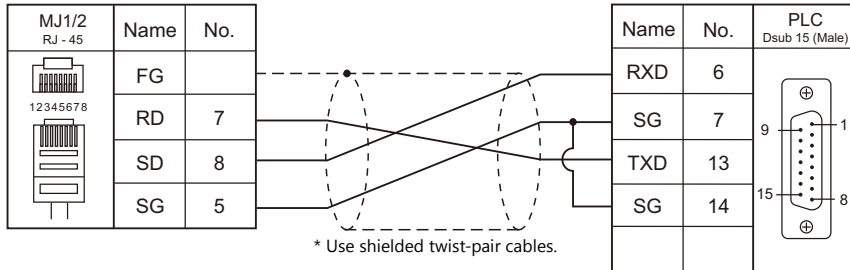

Wiring diagram 5 - M2

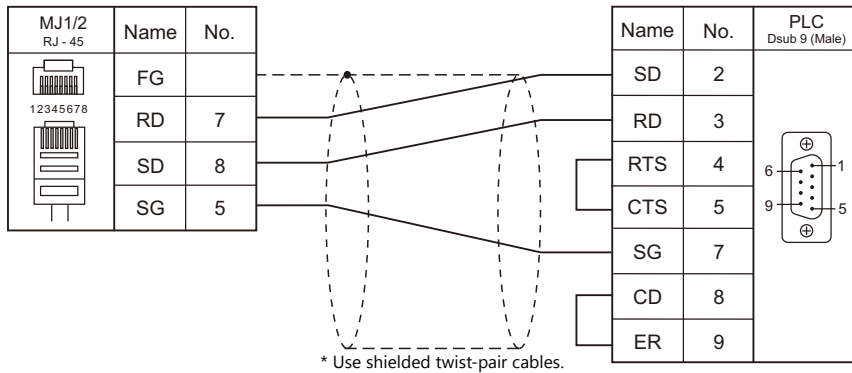

Wiring diagram 6 - M2

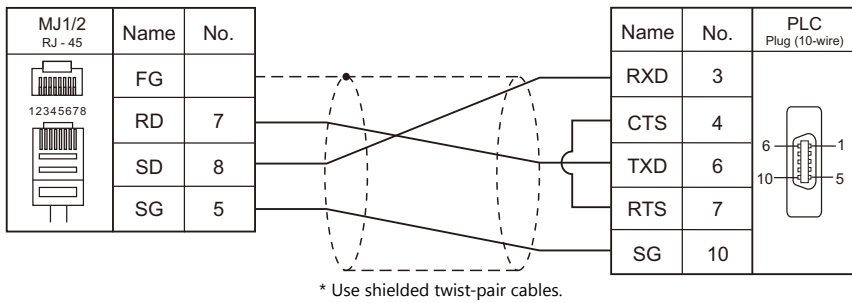

Wiring diagram 7 - M2

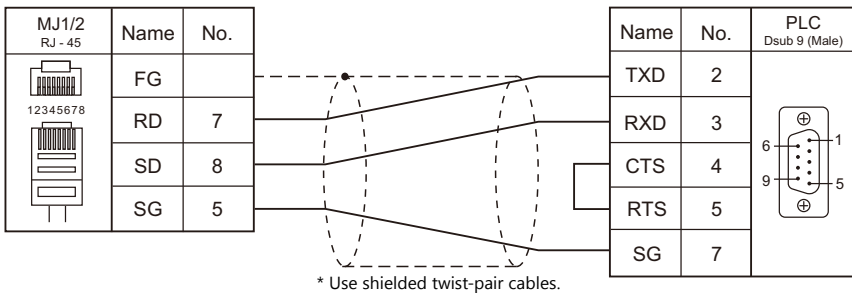

Wiring diagram 8 - M2

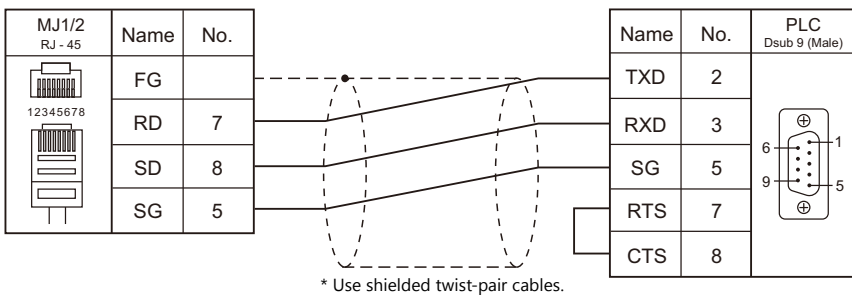

Wiring diagram 9 - M2

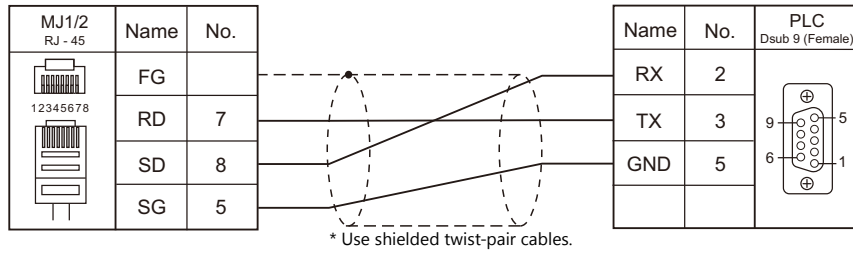

RS-422/RS-485

Wiring diagram 1 - M4

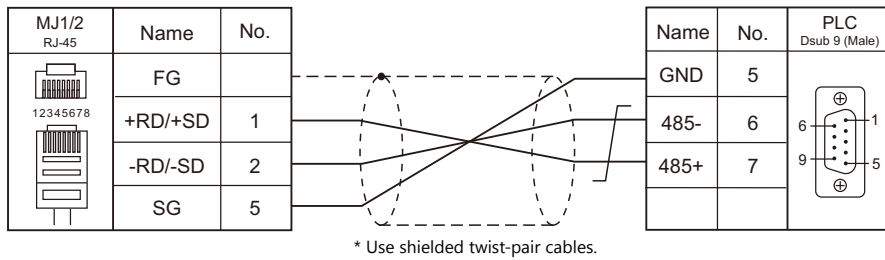

Wiring diagram 2 - M4

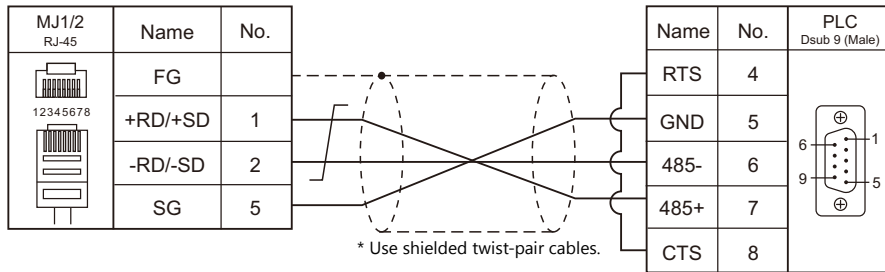

Wiring diagram 3 - M4

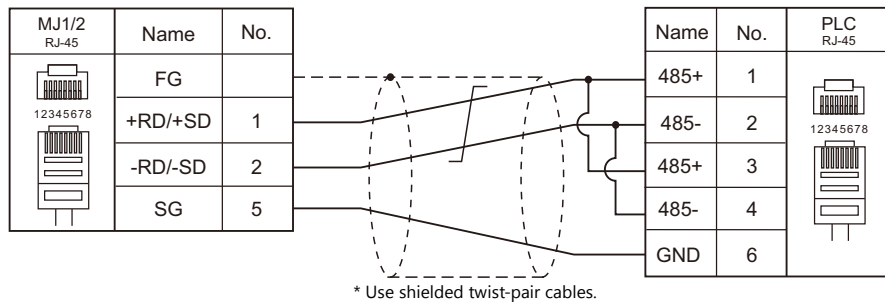

Wiring diagram 4 - M4

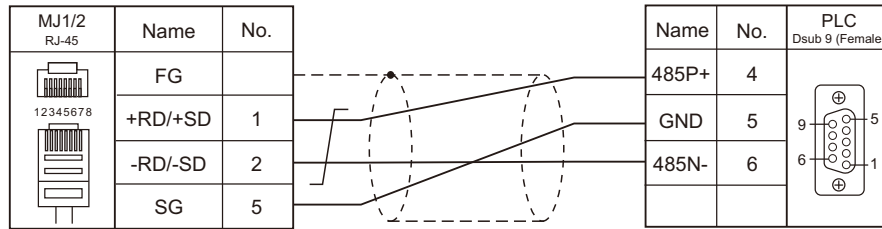

MEMO

Please use this page freely.

Connection Compatibility List

April, 2014

Manufacturer	Models	1 : 1	1 : n Multi-drop	n : 1 Multi-link2	Multi-link2 Ethernet	1 : n Multi-link2 Ethernet	n : 1 Multi-link
Allen-Bradley	PLC-5	○	○	○	○	○	○
	PLC-5 (Ethernet)	○	○				
	Control Logix / Compact Logix	○		○	○		
	Control Logix (Ethernet)	○	○				
	SLC500	○	○	○	○	○	
	SLC500 (Ethernet TCP/IP)	○	○				
	NET-ENI (SLC500 Ethernet TCP/IP)	○	○				
	NET-ENI (MicroLogix Ethernet TCP/IP)	○	○				
	Micro Logix	○	○	○	○	○	
Micro Logix (Ethernet TCP/IP)	○	○					
Automationdirect	Direct LOGIC (K-Sequence)	○		○	○		
	Direct LOGIC (Ethernet UDP/IP)	○	○				
	Direct LOGIC (MODBUS RTU)	○	○	○	○	○	
Azbil	MX series	○	○	○	○	○	
	SDC10	○	○	○	○	○	
	SDC20	○	○	○	○	○	
	SDC21	○	○	○	○	○	
	SDC30/31	○	○	○	○	○	
	SDC35/36	○	○	○	○	○	
	SDC40A	○	○	○	○	○	
	SDC40G	○	○	○	○	○	
	DMC10	○	○	○	○	○	
	DMC50(COM)	○	○	○	○	○	
	AHC2001	○	○	○	○	○	
	AHC2001+DCP31/32	○	○	○	○	○	
	DCP31/32	○	○	○	○	○	
	NX(CPL)	○	○	○	○	○	
	NX(MODBUS RTU)	○	○	○	○	○	
NX(MODBUS TCP/IP)	○	○					
Baumuller	BMx-x-PLC	○		○	○		
BECKHOFF	ADS protocol (Ethernet)	○	○				
CHINO	LT400 Series (MODBUS RTU)	○	○	○	○	○	
	DP1000	○	○	○	○	○	
	DB100B (MODBUS RTU)	○	○	○	○	○	
	KR2000 (MODBUS RTU)	○	○	○	○	○	
	LT230 (MODBUS RTU)	○	○	○	○	○	
	LT300 (MODBUS RTU)	○	○	○	○	○	
	LT830 (MODBUS RTU)	○	○	○	○	○	
CIMON	BP series	○		○	○		
	CP series	○		○	○		
DELTA	DVP series	○	○	○	○	○	
DELTA TAU DATA SYSTEMS	PMAC	○		○	○		
	PMAC(Ethernet TCP/IP)	○	○				
EATON Cutler-Hammer	ELC	○	○	○	○	○	
EMERSON	EC10/20/20H (MODBUS RTU)	○	○	○	○	○	
FANUC	Power Mate	○		○	○		
Fatek Automation	FACON FB Series	○	○	○	○	○	
FUFENG	APC Series Controller	○	○	○	○	○	
Fuji Electric	MICREX-F series	○	○	○	○	○	○
	MICREX-F series V4-compatible	○	○	○	○	○	
	SPB (N mode) & FLEX-PC series	○	○	○	○	○	
	SPB (N mode) and FLEX-PC CPU	○		○	○	○	
	MICREX-SX SPH/SPB series	○		○	○		
	MICREX-SX SPH/SPB CPU	○		○	○		
	MICREX-SX (Ethernet)	○	○				
	PYX (MODBUS RTU)	○	○	○	○	○	
	PXR (MODBUS RTU)	○	○	○	○	○	
	PXG (MODBUS RTU)	○	○	○	○	○	
	PXH (MODBUS RTU)	○	○	○	○	○	
	PUM (MODBUS RTU)	○	○	○	○	○	
	F-MPC04P (loader)	○	○	○	○	○	
	F-MPC series / FePSU	○	○	○	○	○	

Manufacturer	Models	1 : 1	1 : n Multi-drop	n : 1 Multi-link2	Multi-link2 Ethernet	1 : n Multi-link2 Ethernet	n : 1 Multi-link
Fuji Electric	FVR-E11S	○	○	○	○	○	
	FVR-E11S (MODBUS RTU)	○	○	○	○	○	
	FVR-C11S (MODBUS RTU)	○	○	○	○	○	
	FRENIC5000 G11S/P11S	○	○	○	○	○	
	FRENIC5000 G11S/P11S (MODBUS RTU)	○	○	○	○	○	
	FRENIC5000 VG7S (MODBUS RTU)	○	○	○	○	○	
	FRENIC-HVAC/AQUA (MODBUS RTU)	○	○	○	○	○	
	FRENIC-Mini (MODBUS RTU)	○	○	○	○	○	
	FRENIC-Eco (MODBUS RTU)	○	○	○	○	○	
	FRENIC-Multi (MODBUS RTU)	○	○	○	○	○	
	FRENIC-MEGA (MODBUS RTU)	○	○	○	○	○	
	FRENIC-MEGA SERVO(MODBUS RTU)	○	○	○	○	○	
	HFR-C9K	○	○	○	○	○	
	HFR-C11K	○	○	○	○	○	
	PPMC (MODBUS RTU)	○	○	○	○	○	
	FALDIC-α series	○	○	○	○	○	
	FALDIC-W series	○	○	○	○	○	
	PH series	○	○	○	○	○	
	PHR (MODBUS RTU)	○	○	○	○	○	
	WA5000	○	○	○	○	○	
	APR-N (MODBUS RTU)	○	○	○	○	○	
	ALPHA5 (MODBUS RTU)	○	○	○	○	○	
ALPHA5 Smart (MODBUS RTU)	○	○	○	○	○		
WE1MA (Ver. A)(MODBUS RTU)	○	○	○	○	○		
WE1MA (Ver. B)(MODBUS RTU)	○	○	○	○	○		
WSZ series	○	○	○	○	○		
Gammaflux	TTC2100	○	○	○	○	○	
GE Fanuc	90 series	○	○	○	○	○	
	90 series (SNP-X)	○		○	○		
	90 series (SNP)	○	○	○	○	○	
	90 series (Ethernet TCP/IP)	○	○				
	RX3i (Ethernet TCP/IP)	○	○				
Hitachi	HIDIC-S10/2α, S10mini	○		○	○		
	HIDIC-S10/2α, S10mini (Ethernet)	○	○				
	HIDIC-S10/4α	○		○	○		
	HIDIC-S10V	○		○	○		
	HIDIC-S10V (Ethernet)	○	○				
Hitachi Industrial Equipment Systems	HIDIC-H	○	○	○	○	○	○
	HIDIC-H (Ethernet)	○	○				
	HIDIC-EHV	○	○	○	○	○	○
	HIDIC-EHV (Ethernet)	○	○				
	SJ300 series	○	○	○	○	○	
	SJ700 series	○	○	○	○	○	
IAI	X-SEL controller	○	○	○	○	○	
	ROBO CYLINDER (RCP2/ERC)	○	○	○	○	○	
	ROBO CYLINDER (RCS/E-CON)	○	○	○	○	○	
	PCON/ACON/SCON (MODBUS RTU)	○	○	○	○	○	
IDEC	MICRO 3	○	○	○	○	○	
	MICRO Smart	○	○	○	○	○	
	MICRO Smart pentra	○	○	○	○	○	
JTEKT	TOYOPUC	○	○	○	○	○	○
	TOYOPUC (Ethernet)	○	○				
	TOYOPUC (Ethernet PC10 mode)	○	○				
KEYENCE	KZ Series Link	○	○	○	○	○	○
	KZ-A500 CPU	○		○	○		
	KV10/24 CPU	○		○	○		
	KV-700	○		○	○		
	KV-700 (Ethernet TCP/IP)	○	○				
	KV-1000	○		○	○		
	KV-1000 (Ethernet TCP/IP)	○	○				
	KV-3000/5000	○		○	○		
KV-3000/5000 (Ethernet TCP/IP)	○	○					
KOGANEI	IBFL-TC	○	○	○	○	○	
KOYO ELECTRONICS	SU/SG	○	○	○	○	○	
	SR-T (K protocol)	○		○	○		
	SU/SG (K-Sequence)	○		○	○		
	SU/SG (Modbus RTU)	○	○	○	○	○	

Manufacturer	Models	1 : 1	1 : n Multi-drop	n : 1 Multi-link2	Multi-link2 Ethernet	1 : n Multi-link2 Ethernet	n : 1 Multi-link
LS	MASTER-KxxxS	○		○	○		
	MASTER-KxxxS CNET	○	○	○	○	○	
	GLOFA CNET	○	○	○	○	○	○
	GLOFA GM7 CNET	○	○	○	○	○	
	GLOFA GM series CPU	○		○	○		
	XGT/XGK series CNET	○	○	○	○	○	
	XGT/XGK series CPU	○		○	○		
	XGT/XGK series (Ethernet)	○	○				
	XGT/XGI series CNET	○	○	○	○	○	
	XGT/XGI series CPU	○		○	○		
	XGT/XGI series (Ethernet)	○	○				
	MITSUBISHI ELECTRIC	A series link	○	○	○	○	○
A series CPU		○		○	○		
QnA series link		○	○	○	○	○	
QnA series CPU		○		○	○		
QnA series (Ethernet)		○	○				
QnH (Q) series link		○	○	○	○	○	
QnH (Q) series CPU		○		○	○		
QnU series CPU		○		○	○		
Q00J/00/01CPU		○		○	○		
QnH (Q) series (Ethernet)		○	○				
QnH (Q) series link (multi CPU)		○	○	○	○	○	
QnH (Q) series (multi CPU) (Ethernet)		○	○				
QnH (Q) series CPU (multi CPU)		○		○	○		
QnH (Q) series (Ethernet ASCII)		○	○				
QnH (Q) series (multi CPU) (Ethernet ASCII)		○	○				
QnU series (built-in Ethernet)		○	○				
L series link		○	○	○	○	○	
L series (built-in Ethernet)		○	○				
FX series CPU		○		○	○		
FX2N/1N series CPU		○		○	○		
FX1S series CPU		○		○	○		
FX series link (A protocol)		○	○	○	○	○	○
FX-3U/3UC/3G series CPU		○		○	○		
FX-3U series (Ethernet)		○	○				
FX3U/3UC/3UG series link (A protocol)		○	○	○	○	○	○
A-Link + Net10			○				
Q170MCP (multi CPU)		○		○	○		
Q170 series (multi CPU) (Ethernet)		○	○				
FR-*500		○	○	○	○	○	
FR-V500		○	○	○	○	○	
MR-J2S-*A		○	○	○	○	○	
MR-J3-*A		○	○	○	○	○	
MR-J3-*T	○	○	○	○	○		
FR-E700	○	○	○	○	○		
MODICON	Modbus RTU	○		○	○		
MOELLER	PS4	○		○	○		
M-SYSTEM	R1M series (MODBUS RTU)	○	○	○	○	○	

Manufacturer	Models	1 : 1	1 : n Multi-drop	n : 1 Multi-link2	Multi-link2 Ethernet	1 : n Multi-link2 Ethernet	n : 1 Multi-link
OMRON	SYSMAC C	○	○	○	○	○	○
	SYSMAC CV	○	○	○	○	○	○
	SYSMAC CS1/CJ1	○	○	○	○	○	
	SYSMAC CS1/CJ1 DNA	○	○				
	SYSMAC CS1/CJ1 (Ethernet)	○	○				
	SYSMAC CS1/CJ1 (Ethernet Auto)	○	○				
	SYSMAC CS1/CJ1 DNA (Ethernet)	○	○				
	E5AK	○	○	○	○	○	
	E5AK-T	○	○	○	○	○	
	E5AN/E5EN/E5CN/E5GN	○	○	○	○	○	
	E5AR/E5ER	○	○	○	○	○	
	E5CK	○	○	○	○	○	
	E5CK-T	○	○	○	○	○	
	E5CN-HT	○	○	○	○	○	
	E5EK	○	○	○	○	○	
	E5ZD	○	○	○	○	○	
	E5ZE	○	○	○	○	○	
	E5ZN	○	○	○	○	○	
V600/620/680	○	○	○	○	○		
KM20	○	○	○	○	○		
KM100	○	○	○	○	○		
Oriental Motor	High-efficiency AR series (MODBUS RTU)	○	○	○	○	○	
	CRK series (MODBUS RTU)	○	○	○	○	○	
Panasonic	FP Series (RS232C/422)	○	○	○	○	○	○
	FP Series (TCP/IP)	○	○				
	FP Series (UDP/IP)	○	○				
	FP-X (TCP/IP)	○	○				
	FP7 Series (RS232C/422)	○	○	○	○	○	
	FP7 Series (Ethernet)	○	○				
	LP-400	○		○	○		
	KW Series	○	○	○	○	○	
MINAS A4 series	○	○	○	○	○		
RKC	SR-Mini (MODBUS RTU)	○	○	○	○	○	
	CB100/CB400/CB500/CB700/CB900 (MODBUS RTU)	○	○	○	○	○	
	SR-Mini (Standard Protocol)	○	○	○	○	○	
	REX-F400/F700/F900(Standard Protocol)	○	○	○	○	○	
	SRV (MODBUS RTU)	○	○	○	○	○	
	MA900/MA901 (MODBUS RTU)	○	○	○	○	○	
	SRZ (MODBUS RTU)	○	○	○	○	○	
	FB100/FB400/FB900 (MODBUS RTU)	○	○	○	○	○	
RS Automation	NX7/NX Plus Series (70P/700P/CCU+)	○	○	○	○	○	○
	N7/NX Series (70/700/750/CCU)	○	○	○	○	○	○
	NX700 Series (Ethernet)	○	○				
	X8 Series	○	○	○	○	○	
	X8 Series (Ethernet)	○	○				
SAIA	PCD	○	○	○	○	○	
	PCD S-BUS (Ethernet)	○	○				
SAMSUNG	N_plus	○	○	○	○	○	○
	SECNET	○	○	○	○	○	○
SANMEI	Cuty Axis	○	○	○	○	○	
SanRex	DC AUTO (HKD type)	○	○	○	○	○	
SHARP	JW series	○	○	○	○	○	○
	JW100/70H COM port	○	○	○	○	○	○
	JW20 COM port	○	○	○	○	○	○
	JW series (Ethernet)	○	○				
	JW300 series	○	○	○	○	○	○
	JW311/312/321/322 series (Ethernet)	○	○				
JW331/332/341/342/352/362 series (Ethernet)	○	○					
SHIMADEN	SHIMADEN standard protocol	○	○	○	○	○	

Manufacturer	Models	1 : 1	1 : n Multi-drop	n : 1 Multi-link2	Multi-link2 Ethernet	1 : n Multi-link2 Ethernet	n : 1 Multi-link
SHINKO TECHNOS	C Series	○	○	○	○	○	
	FC Series	○	○	○	○	○	
	GC Series	○	○	○	○	○	
	DCL-33A	○	○	○	○	○	
	JCx-300 Series	○	○	○	○	○	
	PC-900	○	○	○	○	○	
	PCD-33A	○	○	○	○	○	
	ACS-13A	○	○	○	○	○	
	ACD/ACR Series	○	○	○	○	○	
WCL-13A	○	○	○	○	○		
Siemens	S5 PG port	○	○	○	○	○	
	S7	○		○	○		
	S7-200 PPI	○	○				○
	S7-200 (Ethernet ISOTCP)	○	○				
	S7-300/400 MPI	○	○				
	S7-300/400 (Ethernet ISOTCP)	○	○				
	S7-300/400 (Ethernet TCP/IP PG protocol)	○	○				
	S7-1200 (Ethernet ISOTCP)	○	○				
TIS00/S05	○	○	○	○	○		
SINFONIA TECHNOLOGY	SELMART	○	○	○	○	○	○
TECO	TP-03 (MODBUS RTU)	○	○	○	○	○	
Telemecanique	TSX Micro						○
TOHO	TTM-000	○	○	○	○	○	
	TTM-00BT	○	○	○	○	○	
	TTM-200	○	○	○	○	○	
TOSHIBA	T series / V series (T compatible)	○	○	○	○	○	○
	EX series	○	○	○	○	○	
	VF-S7	○	○	○	○	○	
	VF-S9	○	○	○	○	○	
	VF-S11	○	○	○	○	○	
	VF-A7	○	○	○	○	○	
	VF-AS1	○	○	○	○	○	
	VF-P7	○	○	○	○	○	
	VF-PS1	○	○	○	○	○	
	VF-FS1	○	○	○	○	○	
VF-nC1	○	○	○	○	○		
TOSHIBA MACHINE	TC200	○	○	○	○	○	
	VELCONIC series		○				
TURCK	BL Series Distributed I/O (MODBUS TCP/IP)	○	○				
UNIPULSE	F340A	○	○	○	○	○	
	F371	○	○	○	○	○	
	F800	○	○	○	○	○	
	F805A	○	○	○	○	○	
	F720A	○	○	○	○	○	
UNITRONICS	M90/M91/Vision Series (ASCII)	○	○	○	○	○	
	Vision Series (ASCII Ethernet TCP/IP)	○	○				
VIGOR	M series	○	○	○	○	○	
WAGO	750 series (MODBUS RTU)	○	○	○	○	○	
	750 series (MODBUS ETHERNET)	○	○				
XINJE	XC Series (MODBUS RTU)	○	○	○	○	○	
YAMAHA	RCX142	○		○	○		
Yaskawa Electric	Memobus	○	○	○	○	○	
	CP9200SH/MP900	○	○	○	○	○	
	MP2000 series	○	○	○	○	○	
	MP2300 (MODBUS TCP/IP)	○	○				
	CP MP expansion memobus (UDP/IP)	○	○				
	MP2000 series (UDP/IP)	○	○				

Manufacturer	Models	1 : 1	1 : n Multi-drop	n : 1 Multi-link2	Multi-link2 Ethernet	1 : n Multi-link2 Ethernet	n : 1 Multi-link
Yokogawa Electric	FA-M3	<input type="radio"/>	<input type="radio"/>	<input type="radio"/>	<input type="radio"/>	<input type="radio"/>	<input type="radio"/>
	FA-M3R	<input type="radio"/>	<input type="radio"/>	<input type="radio"/>	<input type="radio"/>	<input type="radio"/>	<input type="radio"/>
	FA-M3/FA-M3R (Ethernet UDP/IP)	<input type="radio"/>	<input type="radio"/>				
	FA-M3/FA-M3R (Ethernet UDP/IP ASCII)	<input type="radio"/>	<input type="radio"/>				
	FA-M3/FA-M3R (Ethernet TCP/IP)	<input type="radio"/>	<input type="radio"/>				
	FA-M3/FA-M3R (Ethernet TCP/IP ASCII)	<input type="radio"/>	<input type="radio"/>				
	FA-M3V	<input type="radio"/>	<input type="radio"/>	<input type="radio"/>	<input type="radio"/>	<input type="radio"/>	<input type="radio"/>
	FA-M3V (Ethernet)	<input type="radio"/>	<input type="radio"/>				
	FA-M3V(Ethernet ASCII)	<input type="radio"/>	<input type="radio"/>				
	UT100	<input type="radio"/>	<input type="radio"/>	<input type="radio"/>	<input type="radio"/>	<input type="radio"/>	
	UT750	<input type="radio"/>	<input type="radio"/>	<input type="radio"/>	<input type="radio"/>	<input type="radio"/>	
	UT550	<input type="radio"/>	<input type="radio"/>	<input type="radio"/>	<input type="radio"/>	<input type="radio"/>	
	UT520	<input type="radio"/>	<input type="radio"/>	<input type="radio"/>	<input type="radio"/>	<input type="radio"/>	
	UT350	<input type="radio"/>	<input type="radio"/>	<input type="radio"/>	<input type="radio"/>	<input type="radio"/>	
	UT320	<input type="radio"/>	<input type="radio"/>	<input type="radio"/>	<input type="radio"/>	<input type="radio"/>	
UT2400/2800	<input type="radio"/>	<input type="radio"/>	<input type="radio"/>	<input type="radio"/>	<input type="radio"/>		
UT450	<input type="radio"/>	<input type="radio"/>	<input type="radio"/>	<input type="radio"/>	<input type="radio"/>		
None	Universal Serial	<input type="radio"/>	<input type="radio"/>				
	MODBUS RTU	<input type="radio"/>	<input type="radio"/>	<input type="radio"/>	<input type="radio"/>	<input type="radio"/>	
	MODBUS RTU EXT Format	<input type="radio"/>	<input type="radio"/>	<input type="radio"/>	<input type="radio"/>	<input type="radio"/>	
	MODBUS TCP/IP (Ethernet)	<input type="radio"/>	<input type="radio"/>				
	MODBUS TCP/IP (Ethernet) Sub Station	<input type="radio"/>	<input type="radio"/>				
	MODBUS TCP/IP (Ethernet) EXT Format	<input type="radio"/>	<input type="radio"/>				
	MODBUS ASCII	<input type="radio"/>	<input type="radio"/>	<input type="radio"/>	<input type="radio"/>	<input type="radio"/>	

Slave Communication

Manufacturer	Models	Setting	Remarks
None	Universal serial	<input type="radio"/>	
	V-Link	<input type="radio"/>	
	Modbus slave (RTU)	<input type="radio"/>	
	Modbus slave (TCP/IP)	<input type="radio"/>	

Hakko Electronics Co., Ltd.
www.monitouch.com

Sales 890-1, Kamikashiwano-machi, Hakusan-shi, Ishikawa,
924-0035 Japan
TEL +81-76-274-2144 FAX +81-76-274-5136