



Operating Instructions

Control Panels CP600

CP620-x, CP620-x-WEB

CP630-x, CP630-x-WEB

CP635-x, CP635-x-WEB, CP635-Fx

CP651-x, CP651-x-WEB

CP661-x, CP661-x-WEB

CP665-x, CP665-x-WEB

CP676-x, CP676-x-WEB









Content

Introduction	3
Before You Start	4
Safety Notices	4
Markups	4
Product Overview	5
Standards and Approvals	6
Product Identification	6
Technical Specifications	7
Environmental Conditions	7
CP635-Fx:.....	8
Electromagnetic Compatibility (EMC)	9
Durability Information	10
Technical Data	11
Dimensions	15
Installation Environment	16
Applying the Gasket.....	16
Installation Procedure	17
Connections	19
Serial Port	20
Ethernet Port	20
Power Supply, Grounding and Shielding	21
Battery	22
Cleaning Faceplates	23
Getting Started	24
System Settings	25
Dedicated LED Indicators	27
Unpacking and Packing Instructions	28

Introduction

The operational guidelines described below is information which relates to the device, place of employment, transportation, storage, assembly, use and maintenance.

This Operating Instruction describes the main features of the CP600 Control Panels. The Operating Instructions refers to the following models:

Picture	Type	Description
	CP620-x, CP620-x-WEB	Control panel with TFT color 4.3" widescreen display touchscreen
	CP630-x, CP630-x-WEB	Control panel with TFT color 5.7" display touchscreen
	CP635-x, CP635-x-WEB	Control panel with TFT color 7" widescreen display touchscreen
	CP635-Fx	Control panel with TFT color 7" widescreen display touchscreen
	CP651-x, CP651-x-WEB	Control panel with TFT color 10.4" display touchscreen
	CP661-x, CP661-x-WEB	Control panel with TFT color 12.1" display touchscreen
	CP665-x, CP665-x-WEB	Control panel with TFT color 13.3" widescreen display touchscreen
	CP676-x, CP676-x-WEB	Control panel with TFT color 15" display touchscreen

Before You Start

Safety Notices



DANGER!

Indicates an imminent risk. It will lead to death or serious injury if not avoided.



WARNING!

Indicates a possible risk. It may lead to death or serious injury if not avoided.



CAUTION!

Indicates a possible risk. It may lead to light or slight injury or material damage if not avoided.

Markups

- Enumeration.
- ✓ Precondition for an operation instruction or a description.
- Operation instruction with one step.
- 1. Operation instruction with several steps.
 - Result of an operation.



NOTE

Helpful information with background information or an emphasized notice.



TIP

Application tips or other useful information and suggestions.

Product Overview

The Control Panels combine state-of-the-art features and top performance with an outstanding design. They are the ideal choice for all demanding HMI applications including factory and building automation.

These Control Panels have been designed to run the PB610 Panel Builder 600 software.

- PB610 Panel Builder 600 Runtime included. Full compatibility with PB610 Panel Builder 600.
- Full vector graphic support. Native support of SVG graphic objects. Transparency and alpha blending.
- Full object dynamics: Control visibility and transparency, move, resize, rotate any object on screen. Change properties of basic and complex objects.
- TrueType fonts.
- Multilanguage applications. Easily create and manage your applications in multiple languages to meet global requirements. Far East languages are supported. Tools available in PB610 Panel Builder 600 support easy third-party translations and help reducing development and maintenance costs of the application.
- Data display in numerical, text, bargraph, analog gauges and graphic image formats.
- Rich set of state-of-the-art HMI features: Data acquisition, alarm handling, scheduler and timed actions (daily and weekly schedulers, exception dates), recipes, users and passwords, e-mail and RSS feeds, rotating menus.
- Includes support for a set of communication drivers.
- Multiple drivers communication capability.
- Remote monitoring and control. Client-Server functionality.
- Offline and online Simulation with PB610 Panel Builder 600.
- Powerful scripting language for automating HMI applications. Script debugging improves efficiency in application development.
- Rich gallery of vector symbols and objects.
- Project templates.

Standards and Approvals

The Control Panels have been designed for installation and use in an industrial environment in compliance with the 2004/108/EC EMC Directive.

The products have been designed in compliance with:

- | | |
|---------------------------|------------------|
| EN 61000-6-4:2007+A1:2011 | EN 55011 Class A |
| EN 61000-6-2:2005 | EN 61000-4-2 |
| | EN 61000-4-3 |
| | EN 61000-4-4 |
| | EN 61000-4-5 |
| | EN 61000-4-6 |

The installation of these devices into the residential, commercial and light-industrial environments is allowed only in the case that special measures are taken in order to get ensure conformity to EN 61000-6-3.

The products are in compliance with the Restrictions on Certain Hazardous Substances (RoHS) Directive 2011/65/EU. In compliance with the above regulations the products are CE marked.



NOTE

If the mounting surface is not plane and robust enough, the degree IP69K is not guaranteed. A special mounting flange is included to provide the necessary support.

Product Identification

The Control Panel products are identified by a product label. The label reports several information, including the model name, the part number, the power supply, the date of production (in the following format: ywwy) and two barcodes. The first code is the version code, the second one the serial number (S.N.).

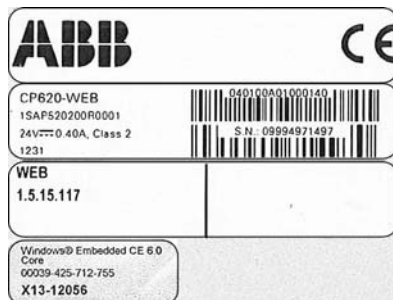

Example of product label

Information on type plate (example)	Description
CP620	Product type
1SAP520200R0001	Product part number
1231	ywwy – week and year of production
09994971497	Serial number
040100A01000140	Version number of the product
WEB 1.5.15.117	Version number of the MicroBrowser (only valid for CP6xx-x-WEB)

Technical Specifications

Parameter	Value
Touchscreen technology	Resistive
Back-up battery	3V 50mAh Lithium, rechargeable, not user-replaceable, model VL2330
Fuse	Automatic
Serial Port	RS-232, RS-485, RS-422 software configurable
User memory	Flash 128 MB for CP620, CP630, CP635 including -x, -x-WEB Flash 256 MB for CP635-Fx, Flash 256 MB for CP651, CP661, CP665, CP676 including -x, -x-WEB
Recipe memory	Flash
Hardware clock	Clock/calendar with back-up battery
Accuracy RTC (at 25 °C operating)	< 100 ppm

Environmental Conditions

Parameter	Value	According to
Operating temperature (surrounding air temperature)	0 °C ... +50 °C for CP635-Fx: -20 °C ... +60 °C	EN 60068-2-14
Storage temperature	-20 °C ... +70 °C for CP635-Fx: -40 °C ... +85 °C	EN 60068-2-14
Operating and storage humidity	5 % ... 85 % RH not-condensing	EN 60068-2-30
Vibrations	5 Hz ... 9 Hz, 7 mm _{p-p} 9 Hz ... 150 Hz, 1 g	EN 60068-2-6
Shock	± 50 g, 11 ms, 3 pulses per axis	EN 60068-2-27
Protection class	IP66 front panel * for CP635-Fx: IP69K	EN 60529

*) The front face of the Control Panel unit, installed in a solid panel, has been tested using conditions equivalent to the standards shown in the "Environmental Conditions". Even though the CP600 unit's level of resistance is equivalent to these standards, oils that should have no effect on the control panel can possibly harm the unit. This can occur in areas where either vaporized oils are present, or where low viscosity cutting oil are allowed to adhere to the unit for long periods of time. If the control panel's front face protection sheet becomes peeled off, these conditions can lead to the ingress of oil into the control panel and separate protection measures are suggested.

If the installation gasket is used for a long period of time, or if the unit and its gasket are removed from the panel, the original level of the protection cannot be guaranteed.

CP635-Fx:

Main Features

- Stainless steel bezel 316/1.440l
- Food-compatible gasket
- Food standard sealing compliant with FDA 21 CFR 177.2006
- PCAP touchscreen, can be operated with gloves for food areas
- Designated according to DIN EN 1672-2
- Designated according to the EHEDG Guideline

Chemical Resistance

Protective front foils are made with high-quality polyester. Polyester withstands exposure of more than 24 h duration under DIN 42 115 Part 2 to wide range of chemicals without visible change.

Sodium hydroxide	50 %
Ammonia	< 32 %
Sulphuric acid	30 %
Acetic acid	< 50 %

IP69K standard	
Water temperature	80 °C (176 °F)
Pressure	8 ... 10 MPa (80 ... 100 bar) (1160 ... 1450 psi)
Flow rate	14 ... 16 l/m (3.7 ... 4 gal/m)
Nozzle distance	10 ... 15 cm (4 ... 6 inch)
Angles	0° 30° 60° 90°
Timing	30 s/each angle

Electromagnetic Compatibility (EMC)

Test executed on the 230 V AC side of the Power Supply (EN 61000-4-11).

Parameter	Value	According to
Radiated disturbance test	Class A	EN 55011
Electrostatic discharge immunity test	8 kV (air electrostatic discharge) 4 kV (contact electrostatic discharge)	EN 61000-4-2
Radiated, radio-frequency, electromagnetic field immunity test	80 MHz ... 1 GHz, 10 V/m 1.4 GHz ... 2 GHz, 3 V/m 2 GHz ... 2.7 GHz, 1 V/m	EN 61000-4-3
Burst immunity test	± 2 kV DC power port ± 1 kV signal line	EN 61000-4-4
Surge immunity test	± 0.5 kV DC power port (line to earth) ± 0.5 kV DC power port (line to line) ± 1 kV signal line (line to earth)	EN 61000-4-5
Immunity to conducted disturbances induced by radio-frequency field	0.15 ... 80 MHz, 10 V	EN 61000-4-6
Voltage dips, short interruptions and voltage variations immunity test	Port: AC mains. Level: 100 % / duration: 1 cycle and 250 cycles (50 Hz); 40 % / duration: 10 cycles (50 Hz); 70 % / duration: 25 cycles (50 Hz); Phase: 0°-180°	

Durability Information

Parameter	Value of CP600	Value of CP635-Fx
Backlight service life (LED type)	MTBF value: 40,000 h (time of continuous operation until the brightness of the backlight reaches 50 % of the rated value when the surrounding temperature reach 25 °C), see ¹	
Battery lifetime	10 years if the surrounding temperature is 25 °C 5 years if the surrounding temperature is 40 °C	
Front foil (without directly expose to sunlight or UV ray)	10 years if the surrounding temperature is 25 °C	
UV Resistance	Indoor applications: After 300 h cycled humidity in QUV accelerated weathering, some yellowing and brittleness may be present.	
Touch panel (resistive film, analog)	1,000,000 or more of activations, see ²	Not applicable (capacitive touchscreen with no mechanical stress), see ³
Touchscreen reliability	> 1 million operations	Not applicable (capacitive touchscreen with no mechanical stress)

¹ Extended use in environments where the surrounding air temperature is 40 °C or higher may degrade backlight quality/reliability/durability.

² Solvent resistance:

Contact for ½ hour at 21 °C, no visible effect: Acetone, Butyl Cellosolve, Cyclohexanone, Ethyl Acetate, Hexane, Isopropyl Alcohol, MEK, Methylene Chloride, Toluene, Xylene

Contact for 24 hours at 49 °C, no visible effect: Coffee, Ketchup, Lemon Juice, Mustard (slight yellow stain), Tea, Tomato Juice.

³ Solvent resistance:

Contact of more than 24 hours, no visible effect: Acetone, Acetic acid <50%, Ammonia <32%, Hydrochloric acid <10%, Hydrogen peroxide <25%, Potassium Hydroxide (Caustic Potash) <2%, Sodium hydroxide 50%, Sodium hypochlorite <20%, Sulphuric Acid 30%, Toluene

Technical Data

Model	CP620-x (-WEB)	CP630-x (-WEB)
Display/Backlight	TFT Color / LED	TFT Color / LED
Colors	64 K	64 K
Resolution	480 x 272	320 x 240
Diagonal (inches)	4.3"	5.7"
Dimming	Yes	Yes
Touchscreen	Yes	Yes
User memory flash	128 MB	128 MB
SC card slot	Yes	Yes
Recipe memory	Yes. Flash memory storage limited only by available memory	Yes. Flash memory storage limited only by available memory
Serial Port	RS-232, RS-485, RS 422, DB9 female, software configurable	RS-232, RS-485, RS 422, DB9 female, software configurable
Ethernet port	2 x 10/100 Mbit/s with integrated switch	2 x 10/100 Mbit/s with integrated switch
USB port	1 x host interface, version 2.0 and 1.1	2 x host interface, 1 version 2.0 and 1.1, 1 version 2.0
Expansion slot for future optional plugin modules	1 x	2 x
Battery	Rechargeable	Rechargeable
Real-time clock	Yes	Yes
Voltage	18 ... 32 V DC *)	18 ... 32 V DC *)
Current rating (at 24 V DC)	0.4 A	0.65 A
Weight	1 kg	1 kg

*) For applications not requiring compliance with EN 61131-2 and specifically in reference to 10 ms voltage dips, the minimum power supply voltage is 10 V DC.

Model	CP635-Fx	CP635-x (-WEB)
Display/Backlight	TFT Color / LED	TFT Color / LED
Colors	64 K	64 K
Resolution	800 x 480	800 x 480
Diagonal (inches)	7" widescreen	7" widescreen
Dimming	Yes	Yes
Touchscreen	Yes	Yes
User memory flash	256 MB	128 MB
SC card slot	Yes	Yes
Recipe memory	Yes. Flash memory storage limited only by available memory	Yes. Flash memory storage limited only by available memory
Serial Port	RS-232, RS-485, RS 422, DB9 female, software configurable	RS-232, RS-485, RS 422, DB9 female, software configurable
Ethernet port	2 x 10/100 Mbit/s with integrated switch	2 x 10/100 Mbit/s with integrated switch
USB port	2 x host interface, 1 version 2.0 and 1.1, 1 version 2.0	2 x host interface, 1 version 2.0 and 1.1, 1 version 2.0
Expansion slot for future optional plugin modules	-	2 x
Battery	Rechargeable	Rechargeable
Real-time clock	Yes	Yes
Voltage	18 ... 32 V DC *)	18 ... 32 V DC *)
Current rating (at 24 V DC)	0.9 A	0.7 A
Weight	1.5 kg	1 kg

*) For applications not requiring compliance with EN 61131-2 and specifically in reference to 10 ms voltage dips, the minimum power supply voltage is 10 V DC.

Model	CP651-x(-WEB)	CP661-x(-WEB)
Display/Backlight	TFT Color / LED	TFT Color / LED
Colors	64 K	64 K
Resolution	800 x 600	800 x 600
Diagonal (inches)	10.4"	12.1"
Dimming	Yes	Yes
Touchscreen	Yes	Yes
User memory flash	256 MB	256 MB
SC card slot	Yes	Yes
Recipe memory	Yes. Flash memory storage limited only by available memory	Yes. Flash memory storage limited only by available memory
Serial Port	RS-232, RS-485, RS-422, DB9 female, software configurable	RS-232, RS-485, RS-422, DB9 female, software configurable
Ethernet port	2 x 10/100 Mbit/s with integrated switch	2 x 10/100 Mbit/s with integrated switch
USB port	2 x host interface, 1 version 2.0 and 1.1, 1 version 2.0	2 x host interface, 1 version 2.0 and 1.1, 1 version 2.0
Expansion slot for future optional plugin modules	2 x	2 x
Battery	Rechargeable	Rechargeable
Real-time clock	Yes	Yes
Voltage	18 ... 32 V DC *)	18 ... 32 V DC *)
Current rating (at 24 V DC)	1 A	1.2 A
Weight	2.1 kg	2.8 kg

*) For applications not requiring compliance with EN 61131-2 and specifically in reference to 10 ms voltage dips, the minimum power supply voltage is 10 V DC.

Model	CP665-x(-WEB)	CP676-x(-WEB)
Display/Backlight	TFT Color / LED	TFT Color / LED
Colors	64 K	64 K
Resolution	1280 x 800	1024 x 768
Diagonal (inches)	13.3"	15"
Dimming	Yes	Yes
Touchscreen	Yes	Yes
User memory flash	256 MB	256 MB
SC card slot	Yes	Yes
Recipe memory	Yes. Flash memory storage limited only by available memory	Yes. Flash memory storage limited only by available memory
Serial Port	RS-232, RS-485, RS-422, DB9 female, software configurable	RS-232, RS-485, RS-422, DB9 female, software configurable
Ethernet port	2 x 10/100 Mbit/s with integrated switch	2 x 10/100 Mbit/s with integrated switch
USB port	2 x host interface, 1 version 2.0 and 1.1, 1 version 2.0	2 x host interface, 1 version 2.0 and 1.1, 1 version 2.0
Expansion slot for future optional plugin modules	2 x	2 x
Battery	Rechargeable	Rechargeable
Real-time clock	Yes	Yes
Voltage	18 ... 32 V DC *)	18 ... 32 V DC *)
Current rating (at 24 V DC)	1.2 A	1.4 A
Weight	2.8 kg	3.5 kg

*) For applications not requiring compliance with EN 61131-2 and specifically in reference to 10 ms voltage dips, the minimum power supply voltage is 10 V DC.

Dimensions

CP620
including -x(-WEB)

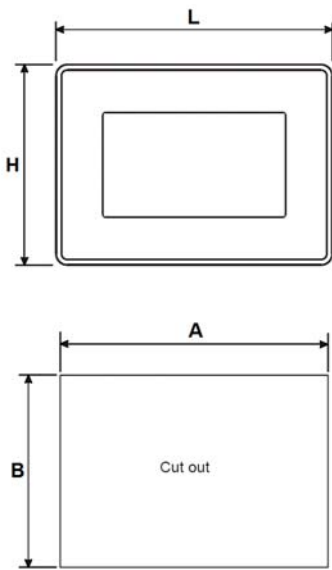

CP630, CP635, CP651, CP661, CP665, CP676
including -x(-WEB), CP635-Fx

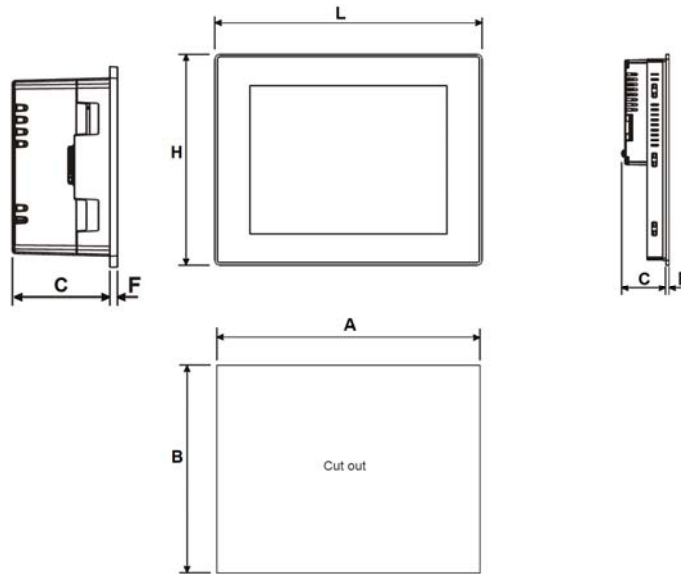

Model	A		B		C		H		L		F	
	mm	inches	mm	inches	mm	inches	mm	inches	mm	inches	mm	inches
CP620-x(-WEB)	136	5.35"	96	3.78"	52	2.05"	107	4.21"	147	5.78"	4	0.16"
CP630-x(-WEB)	176	6.93"	136	5.35"	47	1.85"	147	5.79"	187	7.36"	4	0.16"
CP635-x(-WEB)	176	6.93"	136	5.35"	47	1.85"	147	5.79"	187	7.36"	4	0.16"
CP635-Fx	176	6.93"	136	5.35"	44	1.73"	177	6.96"	217	8.54"	4	0.16"
CP651-x(-WEB)	276	10.87"	221	8.70"	56	2.20"	232	9.13"	287	11.30"	4	0.16"
CP661-x(-WEB)	326	12.83"	256	10.08"	56	2.20"	267	10.51"	336	13.23"	4	0.16"
CP665-x(-WEB)	326	12.83"	256	10.08"	56	2.20"	267	10.51"	336	13.23"	4	0.16"
CP676-x(-WEB)	381	15.00"	296	11.65"	60	2.36"	307	12.09"	392	15.43"	4	0.16"

Model	CSD: Minimum compass safe distance of standard compass		CSD2: Minimum compass safe distance of steering compass, standby steering compass and emergency compass	
	mm	inches	mm	inches
CP620-x(-WEB)	350	13.78"	200	7.87"
CP630-x(-WEB)	350	13.78"	200	7.87"
CP635-x(-WEB)	450	17.72"	250	9.84"
CP635-Fx	N.A.	N.A.	N.A.	N.A.
CP651-x(-WEB)	600	23.62"	400	15.75"
CP661-x(-WEB)	250	9.84"	150	5.91"
CP665-x(-WEB)	500	19.69"	150	5.91"
CP676-x(-WEB)	550	21.65"	300	11.81"

Installation Environment

The equipment is not intended for continuous exposure to direct sunlight. This might accelerate the aging process of the front panel film.

The equipment is not intended for installation in contact with corrosive chemical compounds. Check the resistance of the front panel film to a specific compound before installation.

Do not use tools of any kind (screwdrivers etc.) to operate the touchscreen of the panel.

In order to meet the front panel protection classifications, proper installation procedure must be followed:

- ✓ The borders of the cutout must be flat.
- ✓ The cutout for the panel must be of the dimensions indicated in this manual.
- Screw up each fixing screw until the plastic bezel corner get in contact with the panel.

The IP66 is guaranteed only if:

- Maximum deviation from the plane surface to the cut-out: ≤ 0.5 mm
- Thickness of the plate the equipment is mounted: 1.5 mm to 6 mm
- Maximum surface roughness where the gasket is applied: ≤ 120 μ m

Applying the Gasket

- Apply the gasket on the rear of the frame.



NOTE

If the mounting surface is not plane and robust enough, the degree IP69K is not guaranteed. A special mounting flange is included to provide the necessary support.

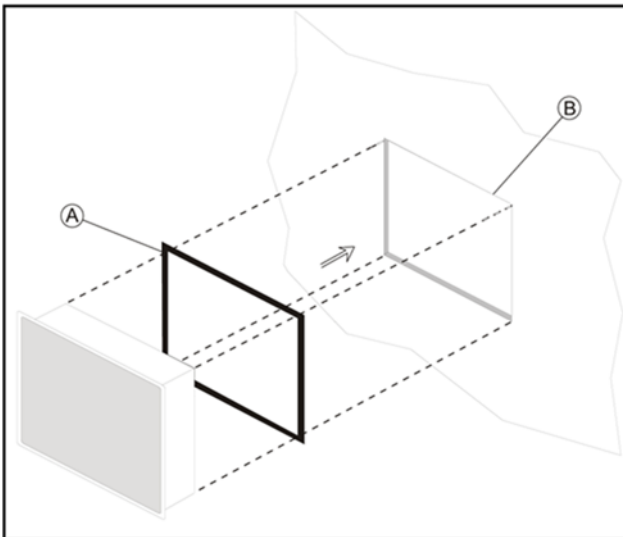

CP620, CP630, CP635
including -x(-WEB) versions

A Gasket

B Installation cut-out

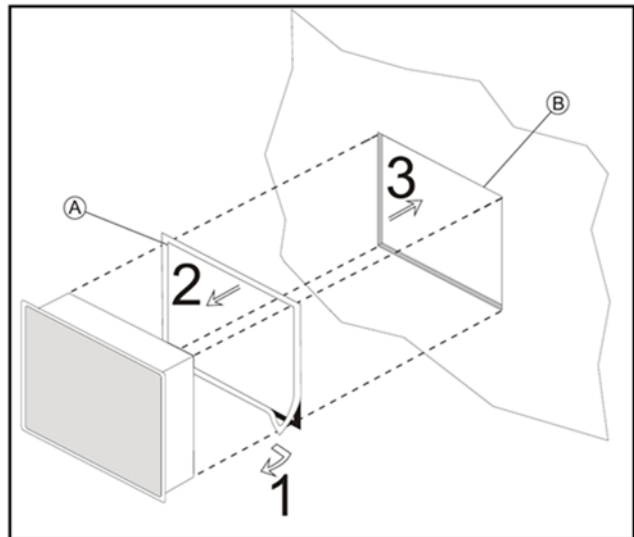

CP650, CP661, CP665, CP676
including -x(-WEB) versions

Installation Procedure

→ Place the fixing brackets.

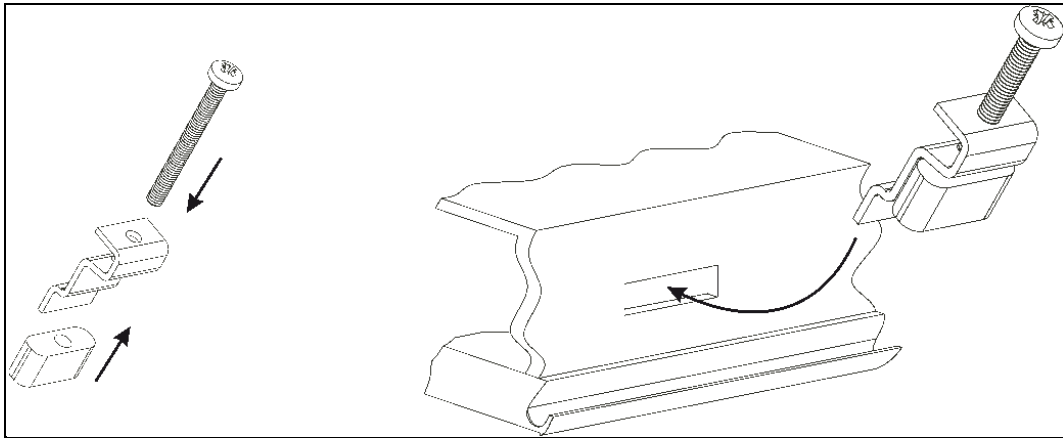

CAUTION!

Screw each fixing screw until the bezel corner gets in contact with the panel.

Communication Cables

The communication cable must be chosen for the type of device being connected.

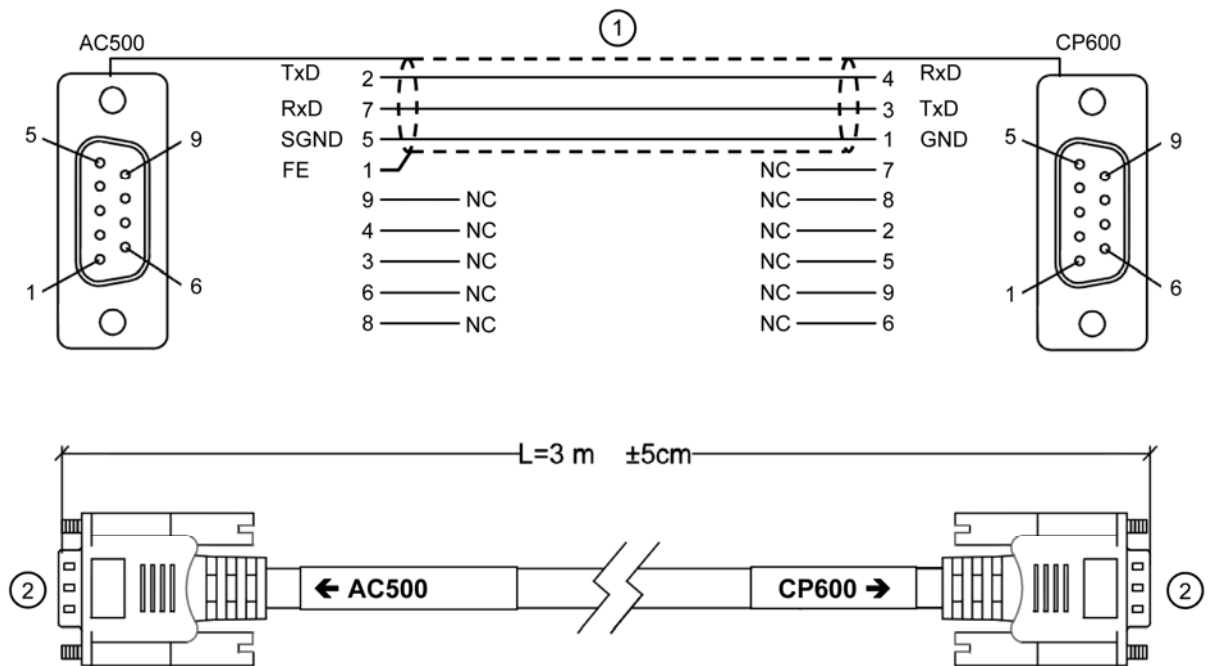

Connection to an AC-500 with the TK681 CP600-AC500 RS232 communication cable

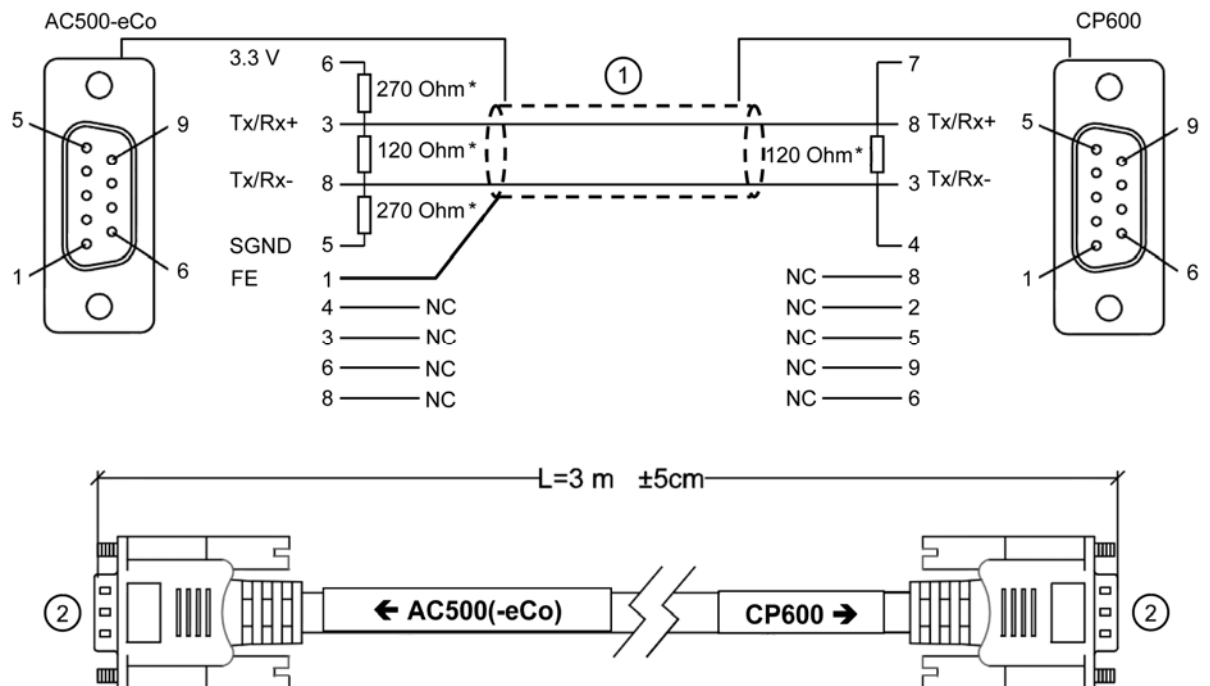

Connection to an AC-500(-eCo) with the TK682 CP600-AC500-eCo RS485 communication cable

*) all resistors: 0.25 W

- 1 Shield 2 SubD9 male

Connections

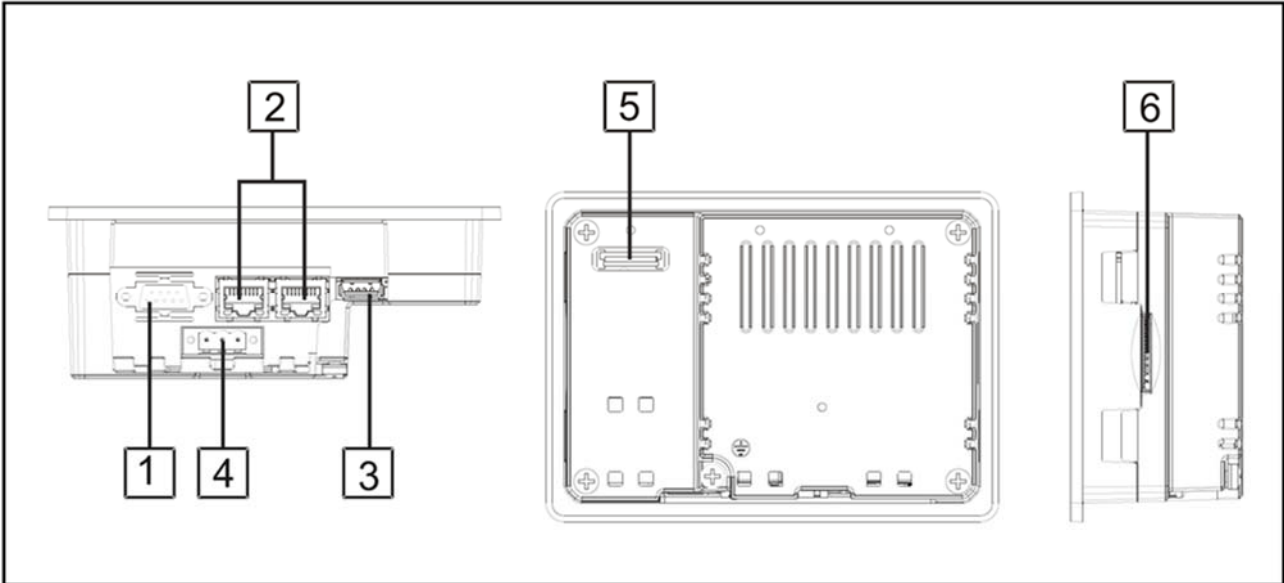

- | | | | | | |
|---|------------------|---|------------------------|---|----------------------------------|
| 1 | Serial port | 3 | USB port | 5 | Expansion slot for plugin module |
| 2 | 2x Ethernet port | 4 | Power supply connector | 6 | SD card slot |

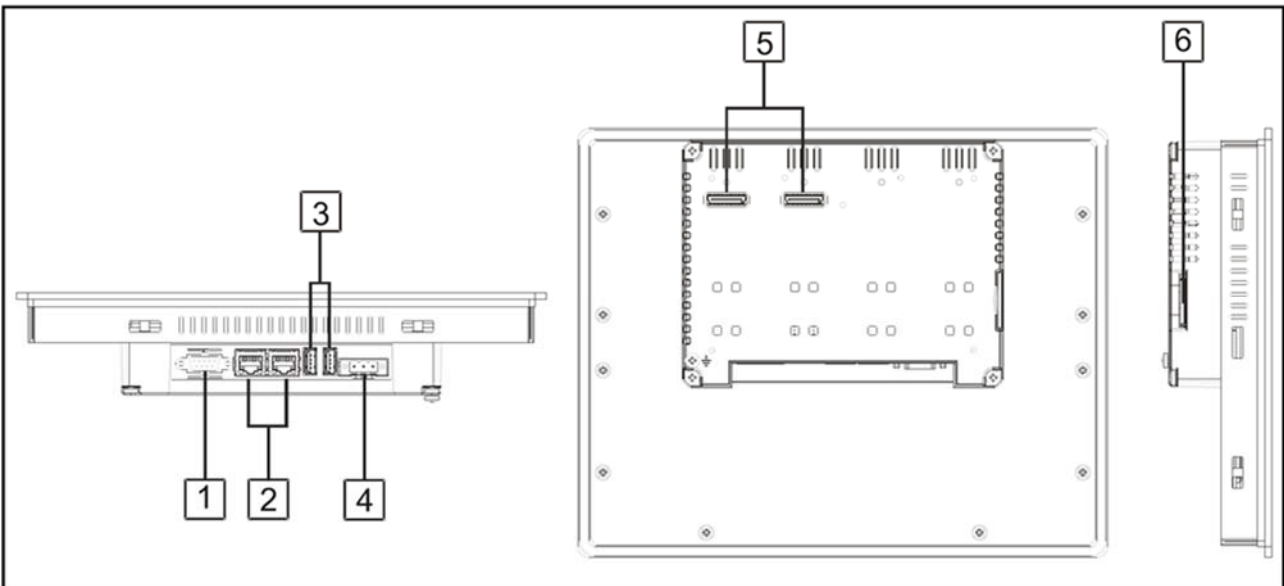

- | | | | | | |
|---|------------------|---|------------------------|---|--------------------------------------|
| 1 | Serial port | 3 | 2x USB port | 5 | 2x Expansion slot for plugin modules |
| 2 | 2x Ethernet port | 4 | Power supply connector | 6 | SD card slot |

Serial Port

The serial port is used to communicate with the PLC or with another type of controller.

Different electrical standards are available for the signals in the PLC port connector: RS-232, RS-422, RS-485.



NOTE

It is always necessary to use the correct cable type to connect on the PLC.
If the proper cable is not used, communication with the PLC will not be possible.

The serial port is software programmable. Make sure you select the appropriate interface in the programming software.

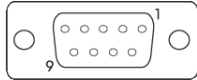

Serial port.

RS-232		RS-422, RS-485	
Pin	Description	Pin	Description
1	GND	1	GND
2		2	
3	TX	3	CHA-
4	RX	4	CHB-
5		5	
6	+5 V output	6	+5 V output
7	CTS	7	CHB+
8	RTS	8	CHA+
9		9	

The communication cable must be chosen for the type of device being connected.

Ethernet Port

The Ethernet port has two status indicators.

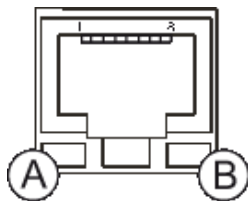

Ethernet Port

A OFF: Valid link has not been detected
ON: Valid link has been detected

B ON: No activity
OFF: Activity

Power Supply, Grounding and Shielding

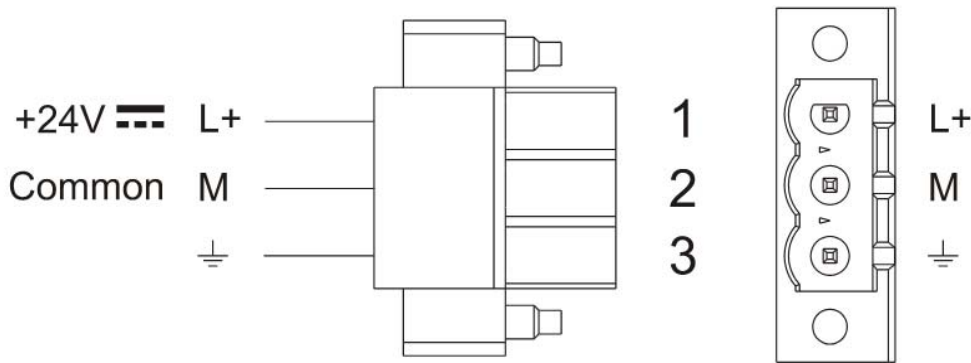

DC Power Connector, Female - R/C Terminal Blocks (XCFR2), manufactured by Weidmüller Inc., Cat. No. BLZ 5.08, torque 4.5 lb-in



NOTE

Ensure that the power supply has enough power capacity for the operation of the equipment.

The unit must always be grounded to earth. Grounding helps limit the effects of noise due to electromagnetic interference on the control system.

1. Do the earth connection using either the screw or the fasten terminal located near the power supply terminal block. A label helps identify the ground connection.
2. Connect to ground the terminal 3 on the power supply terminal block.
3. The power supply circuit may be floating or grounded. In the latter case, connect to ground the power source common as shown in the figure below with a dashed line.

When using the floating power scheme, note that the panes internally connects the power common to ground with a 1 MΩ resistor in parallel with a 4,7 nF capacitor.

The power supply must have double or reinforced insulation.

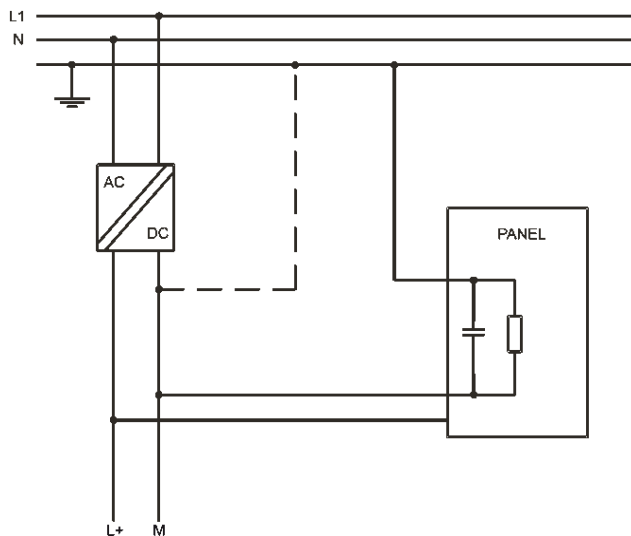

Suggested wiring for the power supply.

All the electronic devices in the control system must be properly grounded. Grounding must be performed according to applicable regulations.

Battery

The Control Panels are equipped with a rechargeable lithium battery, not user-replaceable.
The battery maintains the hardware real-time clock (date and time).

Charging the Battery

- At first installation recharge the battery for 48 h.
 - ▶ When the battery is charged, it assures a period of 3 month of data back-up at 25 °C.

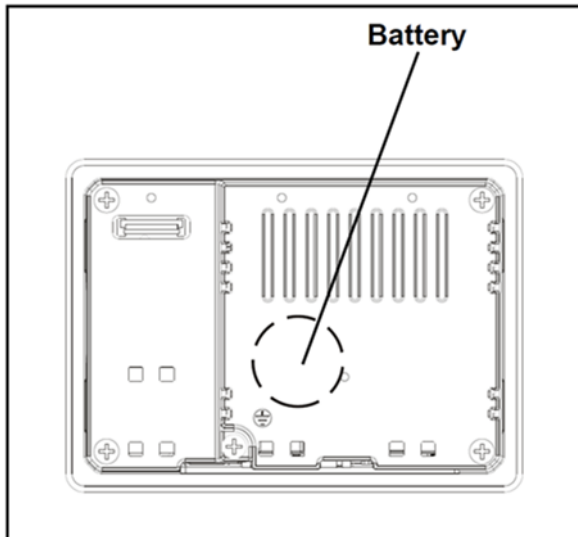

CP620-x(-WEB)

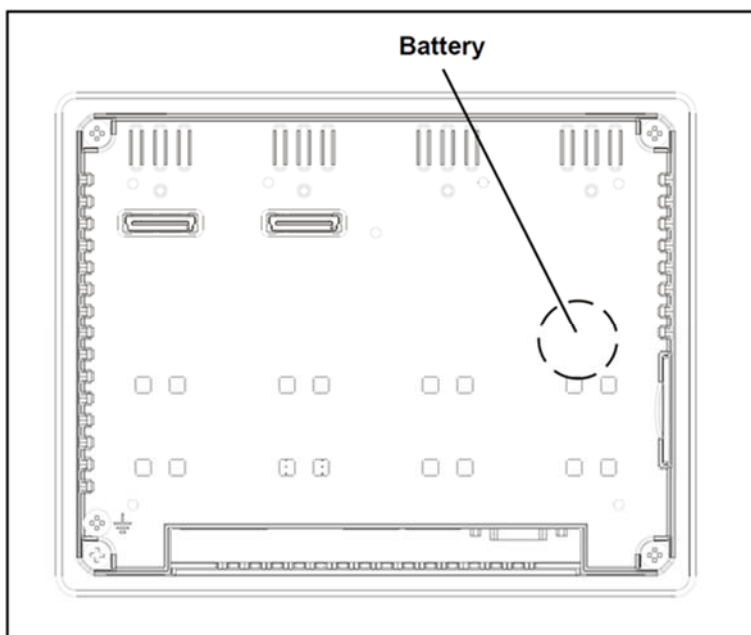

CP630, CP635, CP651, CP661, CP665, CP676 including -x(-WEB) versions



NOTE

The battery must not be disposed as unsorted domestic waste.

→ Dispose the battery according to the local regulations.



Cleaning Faceplates

The equipment must be cleaned only with a soft cloth and neutral soap product. Do not use solvents.

Getting Started

The Control Panels (CP6xx-x, not CP6xx-x-WEB versions) must be programmed with the programming package PB610 Panel Builder 600.

The Control Panels are programmed via the Ethernet interface.

- ✓ The Control Panel must be in configuration mode to be programmed.
- To program a Control Panel connect the Control Panel to a PC running PB610 Panel Builder 600 software package.

The software package PB610 Panel Builder 600 is a Windows™ application and must be properly installed. The Windows™ environment is not included in the software package PB610 Panel Builder 600 and must already be installed on the PC.

PB610 Panel Builder 600 uses the PC Ethernet interface to communicate with the target device.

- Make sure that the proper firewall policy is configured in order to allow PB610 Panel Builder 600 to access the network.

The version of the Panel Builder used must be compatible with the PB610 Panel Builder 600 Runtime version installed on the Control Panel to be programmed. An update of the panel's runtime can be done by means of the programming software.

Check with technical support for more information on compatibility between firmware and programming software.

System Settings

The Control Panels have a system settings tool to allow basic and preliminary settings to the unit.

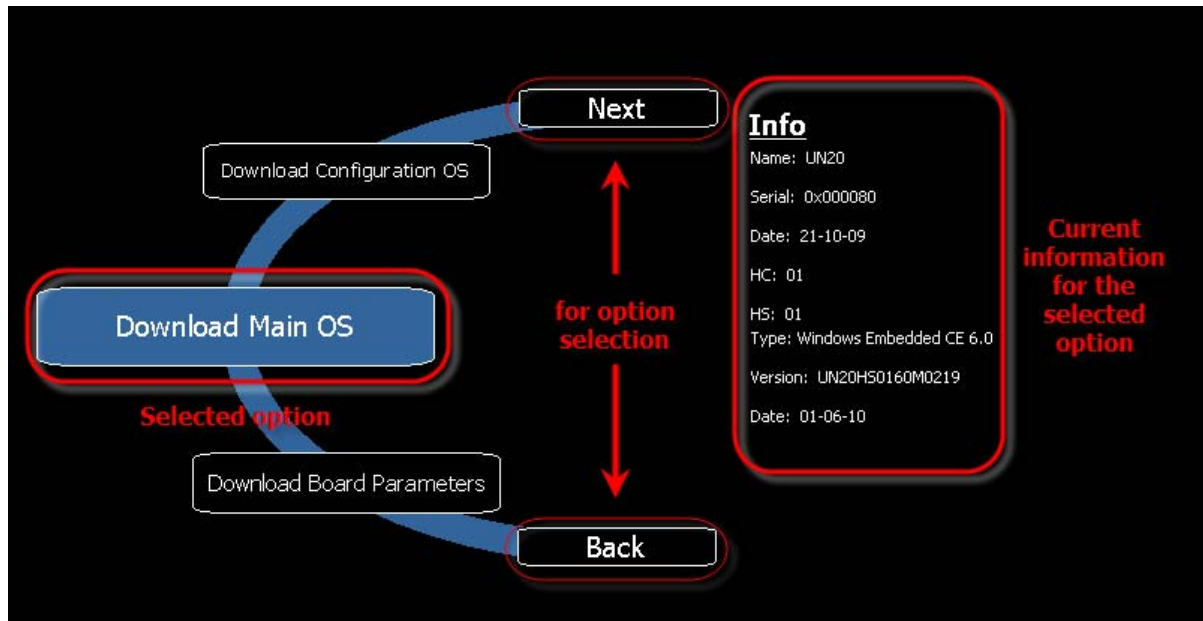

System settings tool

The system settings tool is a rotating menu.

- Use the navigation buttons **Next** and **Back** to scroll between the available options.
 - ▶ On the left side the selected component and function are highlighted.
 - ▶ On the right side, on the "Info" pane, the information about the selected option is shown. For example the version of the Main OS component.

The system settings tool has two operating modes: User Mode and System Mode. The difference between them is the number of available options.

System settings in User Mode is activated from the contextual menu, accessible by clicking and holding any unused area on the touchscreen for a few seconds. Default holding time is 2 sec. This is a runtime parameter that could have been changed.

System settings in System Mode can be activated with the so-called emergency system access procedure. This procedure consists in tapping in the middle of the touchscreen with a finger at a high frequency while the system is powering up. The emergency procedure can only be accessed at power up.

User Mode

User Mode is the simplest possible interface where a generic user can get access to the basic settings of the panel:

- Calibrate Touch: allows to calibrate the touchscreen interface
- Network: allows to change the options of the panel on-board network card
- Time: allows to change the panel RTC (real time clock) options, including time zone and DST (day-light saving time)
- Display settings: automatic backlight turnoff and brightness adjustment
- BSP settings: allows to check the BSP (Board Support Package) version (example 2.37), check the operating hours timers for the unit and separately for the backlight, enable/disable the buzzer, enable/disable the use of the "low battery" front LED indicator

System Mode

- System Mode is the complete interface of the system settings tool where all options are available. Additionally to the options of the User Mode the following options are available:
- Format Flash: allows to format the internal panel flash disk
- Resize Image Area: allows to resize the flash portion reserved to store the splash screen image displayed by the unit at power up.
- Download Configuration OS: allows to check current version and upgrade the back-up operating system.
- Download Main OS: allows to check current version and upgrade the main operating system.
- Download Splash Image: allows changing the splash screen image displayed by the unit at power up; the image should be provide in a specific format. We suggest to update Splash Screen Image directly from Panel Builder software which supports this feature starting from V 1. 50
- Download Bootloader: allows to check current version of the system boot loader and to upgrade it.
- **Only for CP651-x, CP661-x, CP665-x, CP676-x:**
- Download Main FPGA: allows to check current version and upgrade the main FPGA firmware.
- Download Safe FPGA: allows to check current version and upgrade the back-up (safe) copy of the FPGA Firmware.
- Download System Supervisor: allows to check current version and upgrade the system supervisor firmware responsible for RTC and power supply handling.

Dedicated LED Indicators

There is one LED in the upper left part of the front below the red stripe. The meaning of the LED indicator is explained in the following table:

LED color	Status	Meaning
Green	On	Normal Operation
	Blinking	Communication error or alarm requires acknowledgement
Red	On	Hardware fault or battery low

Unpacking and Packing Instructions

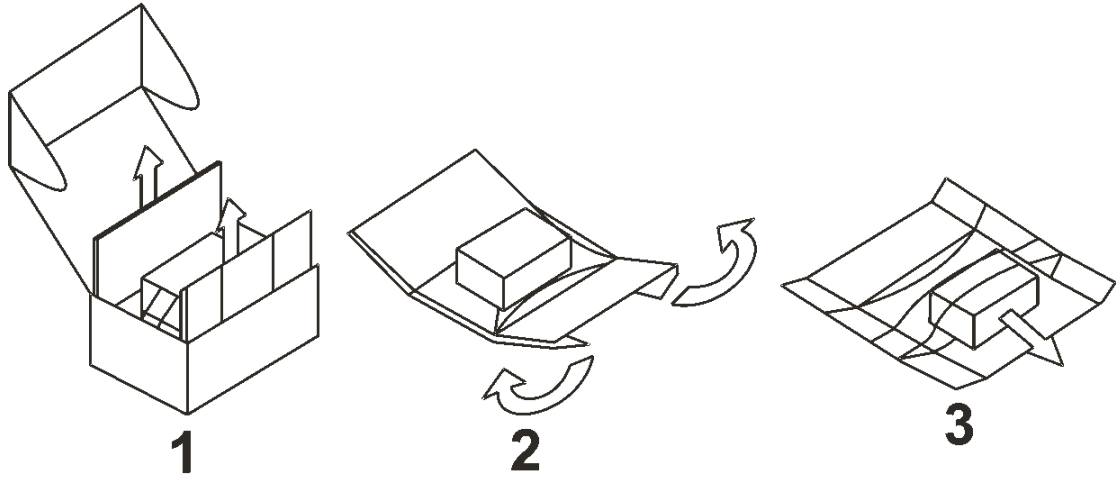

To repack the unit follow the instructions backwards.

Contact us

JOKAB SAFETY DK A/S
Rugmarken 15
3520 Farum
Denmark
Phone: +45 44341454
Mail: info@jokabsafety.dk
Web: www.jokabsafety.dk

Note:

We reserve the right to make technical changes or modify the contents of this document without prior notice. With regard to purchase orders, the agreed particulars shall prevail. ABB AG does not accept any responsibility whatsoever for potential errors or possible lack of information in this document.

We reserve all rights in this document and in the subject matter and illustrations contained therein. Any reproduction, disclosure to third parties or utilization of its contents – in whole or in parts – is forbidden without prior written consent of ABB AG.

© Copyright 2011-2014 ABB.
All rights reserved.
Subject to alterations.

3ADR059030M0204